

# FINAL JEE–MAIN EXAMINATION – APRIL, 2023

**(Held On Thursday 06<sup>th</sup> April, 2023)**

**TIME : 9 : 00 AM to 12 : 00 NOON**

## MATHEMATICS

## TEST PAPER WITH SOLUTION

### SECTION-A

1. Let  $5f(x) + 4f\left(\frac{1}{x}\right) = \frac{1}{x} + 3, x > 0$ . Then  $18 \int_1^2 f(x) dx$

is equal to:

- (1)  $10 \log_e 2 - 6$
- (2)  $10 \log_e 2 + 6$
- (3)  $5 \log_e 2 + 3$
- (4)  $5 \log_e 2 - 3$

**Official Ans. by NTA (1)**

**Sol.**  $5f(x) + 4f\left(\frac{1}{x}\right) = \frac{1}{x} + 3 \dots\dots\dots(1)$

replace  $x \rightarrow \frac{1}{x}$

$$5f\left(\frac{1}{x}\right) + 4f(x) = x + 3 \dots\dots\dots(2)$$

Eq. (1)  $\times$  5 – eq. (2)  $\times$  4

$$f(x) = \frac{1}{9} \left( \frac{5}{x} - 4x + 3 \right)$$

$$I = 18 \int_1^2 \frac{1}{9} \left( \frac{5}{x} - 4x + 3 \right) dx = 10 \log_e 2 - 6$$

2. A pair of dice is thrown 5 times. For each throw, a total of 5 is considered a success. If the probability of at least 4 successes is  $\frac{k}{3^{11}}$ , then k is equal to

- (1) 82
- (2) 123
- (3) 164
- (4) 75

**Official Ans. by NTA (2)**

**Sol.** Probability of success  $= \frac{1}{9} = p$

Probability of failure  $q = \frac{8}{9}$

$P(\text{at least 4 success}) = P(4 \text{ success}) + P(5 \text{ success})$

$$= {}^5C_4 p^4 q + {}^5C_5 p^5 = \frac{41}{3^{10}} = \frac{123}{3^{11}}$$

$k = 123$

3. If  ${}^{2n}C_3 : {}^nC_3 = 10 : 1$ , then the ratio

$(n^2 + 3n) : (n^2 - 3n + 4)$  is

- (1) 35: 16
- (2) 65:37
- (3) 27:11
- (4) 2:1

**Official Ans. by NTA (4)**

**Sol.**  $\frac{{}^{2n}C_3}{{}^nC_3} = 10 \Rightarrow \frac{2n(2n-1)(2n-2)}{n(n-1)(n-2)} = 10$

$$n = 8$$

$$\text{So } (n^2 + 3n) : (n^2 - 3n + 4) = 2$$

4. If the ratio of the fifth term from the beginning to the fifth term from the end in the expansion of

$\left(\sqrt[4]{2} + \frac{1}{\sqrt[4]{3}}\right)^n$  is  $\sqrt{6} : 1$ , then the third term from the

beginning is:

- (1)  $60\sqrt{2}$
- (2)  $60\sqrt{3}$
- (3)  $30\sqrt{2}$
- (4)  $30\sqrt{3}$

**Official Ans. by NTA (2)**

**Sol.**  $\frac{{}^nC_4 2^{\frac{n-4}{4}} \cdot \left(\frac{-1}{3^4}\right)^4}{{}^nC_4 3^{-\frac{(n-4)}{4}} \cdot \left(\frac{1}{2^4}\right)^4} = \frac{\sqrt{6}}{1}$

$$\Rightarrow n = 10$$

$$\text{So } T_3 = {}^{10}C_2 2^{\frac{1}{4} \cdot 8} \cdot 3^{-\frac{1}{4} \cdot 2} = \frac{45 \cdot 4}{\sqrt{3}} = 60\sqrt{3}$$

5. Let  $\vec{a} = 2\hat{i} + 3\hat{j} + 4\hat{k}$ ,  $\vec{b} = 2\hat{i} - 2\hat{j} - 2\hat{k}$  and

$\vec{c} = -\hat{i} + 4\hat{j} + 3\hat{k}$ . If  $\vec{d}$  is a vector perpendicular to

both  $\vec{b}$  and  $\vec{c}$  and  $\vec{a} \cdot \vec{d} = 18$ , Then  $|\vec{a} \times \vec{d}|^2$  is equal

to

- (1) 640
- (2) 760
- (3) 680
- (4) 720

**Official Ans. by NTA (4)**

**Sol.**  $\vec{a} = \lambda(\vec{b} \times \vec{c})$

$$\vec{b} \times \vec{c} = \begin{vmatrix} \hat{i} & \hat{j} & \hat{k} \\ 1 & -2 & -2 \\ -1 & 4 & 3 \end{vmatrix} = 2\hat{i} - \hat{j} + 2\hat{k}$$

$$\vec{d} = \lambda(2\hat{i} - \hat{j} + 2\hat{k})$$

$$\vec{a} \cdot \vec{d} = 18$$

$$\lambda = 2$$

So  $\vec{d} = 2(2\hat{i} - \hat{j} + 2\hat{k})$

$$\vec{d} \times \vec{a} = \begin{vmatrix} \hat{i} & \hat{j} & \hat{k} \\ 4 & -2 & 4 \\ 2 & 3 & 4 \end{vmatrix} = -20\hat{i} - 8\hat{j} + 16\hat{k}$$

$$|\vec{d} \times \vec{a}|^2 = 720$$

6. The straight lines  $l_1$  and  $l_2$  pass through the origin and trisect the line segment of the line  $L: 9x + 5y = 45$  between the axes. If  $m_1$  and  $m_2$  are the slopes of the lines  $l_1$  and  $l_2$ , then the point of intersection of the line  $y = (m_1 + m_2)x$  with  $L$  lies on

(1)  $6x + y = 10$

(2)  $6x - y = 15$

(3)  $y - x = 5$

(4)  $y - 2x = 5$

**Official Ans. by NTA (3)**

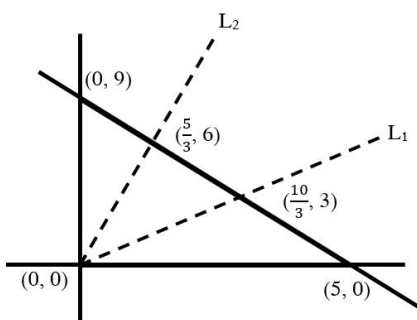

**Sol.**

$$m_{L_1} = \frac{3.3}{10} = \frac{9}{10}$$

$$m_{L_2} = \frac{6.3}{5} = \frac{18}{5}$$

$$y = (m_1 + m_2)x$$

$$y = \frac{9}{2}x$$

Point of intersection with  $L$  is  $(\frac{10}{7}, \frac{45}{7})$

7. From the top  $A$  of a vertical wall  $AB$  of height 30 m, the angles of depression of the top  $P$  and bottom  $Q$  of a vertical tower  $PQ$  are  $15^\circ$  and  $60^\circ$  respectively.  $B$  and  $Q$  are on the same horizontal level. If  $C$  is a point on  $AB$  such that  $CB = PQ$ , then the area (in  $m^2$ ) of the quadrilateral  $BCPQ$  is equal to

(1)  $600(\sqrt{3} - 1)$

(2)  $300(\sqrt{3} + 1)$

(3)  $200(3 - \sqrt{3})$

(4)  $300(\sqrt{3} - 1)$

**Official Ans. by NTA (1)**

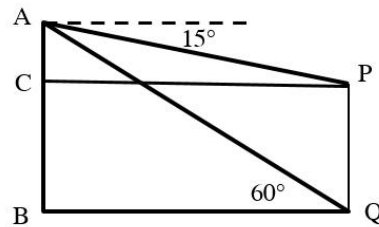

**Sol.**

$$\tan 60^\circ = \sqrt{3} = \frac{30}{BQ}$$

$$BQ = 10\sqrt{3}m = CP$$

$$\tan 15^\circ = 2 - \sqrt{3} = \frac{AC}{CP}$$

$$AC = 10\sqrt{3}(2 - \sqrt{3})$$

$$\text{Area} = 10\sqrt{3}(60 - 20\sqrt{3}) = 600(\sqrt{3} - 1)$$

8. The sum of the first 20 terms of the series  $5 + 11 + 19 + 29 + 41 + \dots$  is

(1) 3450

(2) 3250

(3) 3420

(4) 3520

**Official Ans. by NTA (4)**

**Sol.**  $S_{20} = 5 + 11 + 19 + 29 + \dots$

$$\text{Let } T_r = ar^2 + br + c$$

$$T_1 = a + b + c = 5$$

$$T_2 = 4a + 2b + c = 11$$

$$T_3 = 9a + 3b + c = 19$$

$$a = 1, b = 3, c = 1$$

$$\text{Hence } S_{20} = \sum_{r=1}^{20} r^2 + 3 \sum_{r=1}^{20} r + \sum_{r=1}^{20} 1 = 3520$$

9. The mean and variance of a set of 15 numbers are 12 and 14 respectively. The mean and variance of another set of 15 numbers are 14 and  $\sigma^2$  respectively. If the variance of all the 30 numbers in the two sets is 13, then  $\sigma^2$  is equal to

- (1) 9  
 (2) 12  
 (3) 11  
 (4) 10

**Official Ans. by NTA (4)**

**Sol.** Combine var. =  $\frac{n_1\sigma^2 + n_2\sigma^2}{n_1 + n_2} + \frac{n_1n_2(m_1 - m_2)^2}{(n_1 + n_2)^2}$

$$13 = \frac{15 \cdot 14 + 15 \cdot \sigma^2}{30} + \frac{15 \cdot 15(12 - 14)^2}{30 \times 30}$$

$$13 = \frac{14 + \sigma^2}{2} + \frac{4}{4}$$

$$\sigma^2 = 10$$

10. Let  $A = [a_{ij}]_{2 \times 2}$  where  $a_{ij} \neq 0$  for all  $i, j$  and  $A^2 = I$ . Let  $a$  be the sum of all diagonal elements of  $A$  and  $b = |A|$ , then  $3a^2 + 4b^2$  is equal to

- (1) 7  
 (2) 14  
 (3) 3  
 (4) 4

**Official Ans. by NTA (4)**

**Sol.** Let  $A = \begin{bmatrix} p & q \\ r & s \end{bmatrix}$

$$A^2 = \begin{bmatrix} p^2 + qr & pq + qs \\ pr + rs & qs + s^2 \end{bmatrix}$$

$$\Rightarrow p^2 + qr = 1 \quad (1) \quad pq + qs = 0 \Rightarrow q(p+s) = 0 \quad (3)$$

$$\Rightarrow s^2 + qr = 1 \quad (2) \quad pr + rs = 0 \Rightarrow r(p+s) = 0 \quad (4)$$

Equation (1) – equation (2)

$$p^2 = s^2 \Rightarrow p+s=0$$

$$\text{Now } 3a^2 + 4b^2$$

$$= 3(p+s)^2 + 4(ps - qr)^2$$

$$= 3 \cdot 0 + 4(-p^2 - qr)^2 = 4(p^2 + qr)^2 = 4$$

11. Let  $I(x) = \int \frac{x^2 \sec^2 x + \tan x}{(x \tan x + 1)^2} dx$ . If  $I(0) = 0$  the  $I$

$\left(\frac{\pi}{4}\right)$  is equal to

(1)  $\log_e \frac{(x+4)^2}{16} - \frac{\pi^2}{4(\pi+4)}$

(2)  $\log_e \frac{(x+4)^2}{16} + \frac{\pi^2}{4(\pi+4)}$

(3)  $\log_e \frac{(x+4)^2}{32} - \frac{\pi^2}{4(\pi+4)}$

(4)  $\log_e \frac{(x+4)^2}{32} + \frac{\pi^2}{4(\pi+4)}$

**Official Ans. by NTA (3)**

**Sol.**  $I(x) = \int \frac{x^2(x \sec^2 x + \tan x)}{(x \tan x + 1)^2} dx$

Let  $x \tan x + 1 = t$

$$I = x^2 \left( \frac{-1}{x \tan x + 1} \right) + \int \frac{2x}{x \tan x + 1} dx$$

$$I = x^2 \left( \frac{-1}{x \tan x + 1} \right) + 2 \int \frac{x \cos x}{x \sin x + \cos x} dx$$

$$I = x^2 \left( \frac{-1}{x \tan x + 1} \right) + 2 \ln |x \sin x + \cos x| + C$$

$$\text{As } I(0) = 0 \Rightarrow C = 0$$

$$I\left(\frac{\pi}{4}\right) = \ln \left( \frac{(\pi+4)^2}{32} \right) - \frac{\pi^2}{4(\pi+4)}$$

12. If the equation of the plane passing through the line of intersection of the planes  $2x - y + z = 3$ ,  $4x - 3y + 5z + 9 = 0$  and parallel to the line

$$\frac{x+1}{-2} = \frac{y+3}{4} = \frac{z-2}{5} \text{ is } ax + by + cz + 6 = 0. \text{ then } a$$

$+ b + c$  is equal to

- (1) 14  
 (2) 12  
 (3) 13  
 (4) 15

**Official Ans. by NTA (1)**

**Sol. Equation of family of plane**

$$(2x - y + z - 3) + \lambda(4x - 3y + 5z + 9) = 0$$

$$x(2 + 4\lambda) - y(1 + 3\lambda) + z(1 + 5\lambda) - 3 + 9\lambda = 0$$

Parallel to the line

$$-2(2 + 4\lambda) - (1 + 3\lambda)4 + (1 + 5\lambda)5 = 0$$

$$5\lambda = 3$$

$$\lambda = \frac{3}{5}$$

equation of plane

$$11x - 7y + 10z + 6 = 0$$

$$a + b + c = 14$$

**13.** Statement  $(P \Rightarrow Q) \wedge (R \Rightarrow Q)$  is logically equivalent to

(1)  $(P \vee R) \Rightarrow Q$

(2)  $(P \Rightarrow R) \wedge (Q \Rightarrow R)$

(3)  $(P \Rightarrow R) \vee (Q \Rightarrow R)$

(4)  $(P \wedge R) \Rightarrow Q$

**Official Ans. by NTA (1)**

**Sol.**  $(P \Rightarrow Q) \wedge (R \Rightarrow Q)$

**We known that**  $P \Rightarrow Q \equiv \sim P \vee Q$

$$\Rightarrow (\sim P \vee Q) \wedge (\sim R \vee Q)$$

$$\Rightarrow (\sim P \wedge \sim R) \vee Q$$

$$\Rightarrow \sim (P \vee R) \vee Q$$

$$\Rightarrow (P \vee R) \Rightarrow Q$$

**14.** The sum of all the roots of the equation

$$|x^2 - 8x + 15| - 2x + 7 = 0 \text{ is:}$$

(1)  $9 + \sqrt{3}$

(2)  $11 + \sqrt{3}$

(3)  $9 - \sqrt{3}$

(4)  $11 - \sqrt{3}$

**Official Ans. by NTA (1)**

**Sol. For**  $x \leq 3$  or  $x \geq 5$

$$x^2 - 8x + 15 - 2x + 7 = 0$$

$$x = 5 + \sqrt{3}$$

For  $3 < x < 5$ ,  $x^2 - 8x + 15 + 2x - 7 = 0$

$$x = 4$$

Hence sum =  $9 + \sqrt{3}$

**15.** Let  $a_1, a_2, a_3, \dots, a_n$  be  $n$  positive consecutive terms of an arithmetic progression. If  $d > 0$  is its common difference, then

$$\lim_{n \rightarrow \infty} \sqrt{\frac{d}{n}} \left( \frac{1}{\sqrt{a_1} + \sqrt{a_2}} + \frac{1}{\sqrt{a_2} + \sqrt{a_3}} + \dots + \frac{1}{\sqrt{a_{n-1}} + \sqrt{a_n}} \right)$$

(1) 1

(2)  $\sqrt{d}$

(3)  $\frac{1}{\sqrt{d}}$

(4) 0

**Official Ans. by NTA (1)**

**Sol.**  $\lim_{n \rightarrow \infty} \sqrt{\frac{d}{n}} \left( \frac{1}{\sqrt{a_1} + \sqrt{a_2}} + \frac{1}{\sqrt{a_2} + \sqrt{a_3}} + \dots + \frac{1}{\sqrt{a_{n-1}} + \sqrt{a_n}} \right)$

On rationalising each term

$$\lim_{n \rightarrow \infty} \sqrt{\frac{d}{n}} \left( \frac{\sqrt{a_n} - \sqrt{a_1}}{d} \right)$$

$$\lim_{n \rightarrow \infty} \sqrt{\frac{d}{n}} \left( \frac{(n-1)d}{(\sqrt{a_n} + \sqrt{a_1})d} \right) = 1$$

**16.** If the system of equations

$$x + y + az = b$$

$$2x + 5y + 2z = 6$$

$$x + 2y + 3z = 3$$

has infinitely many solutions, then  $2a + 3b$  is equal to

(1) 23

(2) 28

(3) 25

(4) 20

**Official Ans. by NTA (1)**

**Sol.**  $\Delta = \begin{vmatrix} 1 & 1 & a \\ 2 & 5 & 2 \\ 1 & 2 & 3 \end{vmatrix} = 0 \Rightarrow 11 - 4 - a = 0$

$$a = 7$$

$$\Delta_1 = \begin{vmatrix} b & 1 & a \\ 6 & 5 & 2 \\ 3 & 2 & 3 \end{vmatrix} = 0 \Rightarrow 11b - 12 - 21 = 0$$

$$b = 3$$

$$2a + 3b = 23$$

17. If  $2x^y + 3y^x = 20$ , then  $\frac{dy}{dx}$  at  $(2, 2)$  is equal to

- (1)  $-\left(\frac{3 + \log_e 8}{2 + \log_e 4}\right)$       (2)  $-\left(\frac{2 + \log_e 8}{3 + \log_e 4}\right)$   
 (3)  $-\left(\frac{3 + \log_e 16}{4 + \log_e 8}\right)$       (4)  $-\left(\frac{3 + \log_e 4}{2 + \log_e 8}\right)$

**Official Ans. by NTA (2)**

**Sol.**  $2x^y + 3y^x = 20$

$$2x^y \left[ \frac{y}{x} + (\ln x) y' \right] + 3y^x \left[ \frac{xy'}{y} + \ln y \right] = 0$$

$$y' = \frac{-(12 \ln 2 + 8)}{12 + 8 \ln 2} = -\left(\frac{2 + \log_e 8}{3 + \log_e 4}\right)$$

18. One vertex of a rectangular parallelopiped is at the origin O and the lengths of its edges along x, y and z axes are 3, 4 and 5 units respectively. Let P be the vertex (3, 4, 5). Then the shortest distance between the diagonal OP and an edge parallel to z axis, not passing through O or P is:

- (1)  $\frac{12}{\sqrt{5}}$       (2)  $\frac{12}{5\sqrt{5}}$   
 (3)  $12\sqrt{5}$       (4)  $\frac{12}{5}$

**Official Ans. by NTA (4)**

**Sol** Equation of OP is  $\frac{x}{3} = \frac{y}{4} = \frac{z}{5}$

$$a_1 = (0, 0, 0) \quad a_2 = (3, 0, 5)$$

$$b_1 = (3, 4, 5) \quad b_2 = (0, 0, 1)$$

Equation of edge parallel to z axis

$$\frac{x-3}{0} = \frac{y-0}{0} = \frac{z-5}{1}$$

$$S.D = \frac{(\vec{a}_2 - \vec{a}_1) \cdot (\vec{b}_1 \times \vec{b}_2)}{|\vec{b}_1 \times \vec{b}_2|}$$

$$\frac{\begin{vmatrix} 3 & 0 & 5 \\ 3 & 4 & 5 \\ 0 & 0 & 1 \end{vmatrix}}{\begin{vmatrix} \hat{i} & \hat{j} & \hat{k} \\ 3 & 4 & 5 \\ 0 & 0 & 1 \end{vmatrix}} = \frac{3(4)}{|4\hat{i} - 3\hat{j}|} = \frac{12}{5}$$

19. Let the position vectors of the points A, B, C and D be  $5\hat{i} + 5\hat{j} + 2\lambda\hat{k}$ ,  $\hat{i} + 2\hat{j} + 3\hat{k}$ ,  $-2\hat{i} + \lambda\hat{j} + 4\hat{k}$  and  $-\hat{i} + 5\hat{j} + 6\hat{k}$ . Let the set  $S = \{\lambda \in \mathbb{R} : \text{The points A, B, C and D are coplanar}\}$ . Then  $\sum_{\lambda \in S} (\lambda + 2)^2$  is equal

to

- (1) 41      (2) 25  
 (3) 13      (4)  $\frac{37}{2}$

**Official Ans. by NTA (1)**

**Sol.** Since A, B, C, D are coplaner

$$\text{Hence } [\overline{BA} \quad \overline{CA} \quad \overline{DA}] = 0$$

$$\begin{vmatrix} 4 & 3 & 2\lambda - 3 \\ 7 & 5 - \lambda & 2\lambda - 4 \\ 6 & 0 & 2\lambda - 6 \end{vmatrix} = 0$$

$$\lambda = 2, 3 \text{ Hence } \sum_{\lambda \in S} (\lambda + 2)^2 = 41$$

20. Let  $A = \{x \in \mathbb{R} : [x + 3] + [x + 4] \leq 3\}$ ,

$$B = \left\{ x \in \mathbb{R} : 3^x \left( \sum_{r=1}^{\infty} \frac{3}{10^r} \right)^{x-3} < 3^{-3x} \right\}, \text{ where } [t]$$

denotes greatest integer function. Then,

- (1)  $A \cap B = \phi$   
 (2)  $A = B$   
 (3)  $B \subset C, A \neq B$   
 (4)  $A \subset B, A \neq B$

**Official Ans. by NTA (2)**

**Sol.**  $[x] + 3 + [x] + 4 \leq 3$

$$2[x] \leq -4$$

$$[x] \leq -2 \Rightarrow x \in (-\infty, -1) \dots \dots \dots (A)$$

$$3^x \left( \frac{3 \cdot \frac{1}{10}}{1 - \frac{1}{10}} \right)^{x-3} < 3^{-3x}$$

$$27 < 3^{-3x}$$

$$-3x > +3$$

$$x < -1 \dots \dots \dots (B)$$

$$A = B$$

**SECTION-B**

21. Let  $a \in \mathbb{Z}$  and  $[t]$  be the greatest integer  $\leq t$ . Then the number of points, where the function  $f(x) = [a + 13 \sin x]$ ,  $x \in (0, \pi)$  is not differentiable, is \_\_\_\_\_

**Official Ans. by NTA (25)**

**Sol.**  $f(x) = [a + 13 \sin x]$ ,  $x \in (0, \pi)$

For  $[n \sin x]$ ; Total number of non differentiable points are  $= 2n - 1$  for  $x \in (0, \pi)$

So number of non differentiable points for  $[13 \sin x] \Rightarrow 25$  Points

22. A circle passing through the point  $P(\alpha, \beta)$  in the first quadrant touches the two coordinate axes at the points A and B. The point P is above the line AB. The point Q on the line segment AB is the foot of perpendicular from P on AB. If PQ is equal to 11 units, then the value of  $\alpha\beta$  is \_\_\_\_\_

**Official Ans. by NTA (121)**

**Sol.**

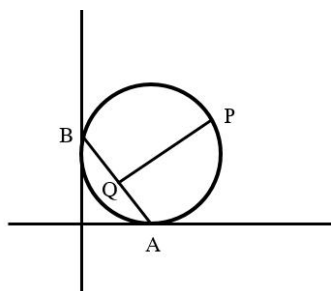

Let equation of circle is  $(x - a)^2 + (y - a)^2 = a^2$

which is passing through  $P(\alpha, \beta)$

$$\text{then } (\alpha - a)^2 + (\beta - a)^2 = a^2$$

$$\alpha^2 + \beta^2 - 2\alpha a - 2\beta a + a^2 = 0$$

Here equation of AB is  $x + y = a$

Let Q  $(\alpha', \beta')$  be foot of perpendicular of P on AB

$$\frac{\alpha' - \alpha}{1} = \frac{\beta' - \beta}{1} = \frac{-(\alpha + \beta - a)}{2}$$

$$PQ^2 = (\alpha' - \alpha)^2 + (\beta' - \beta)^2 = \frac{1}{4}(\alpha + \beta - a)^2 + \frac{1}{4}(\alpha + \beta - a)^2$$

$$121 = \frac{1}{2}(\alpha + \beta - a)^2$$

$$242 = \alpha^2 + \beta^2 - 2\alpha a - 2\beta a + a^2 + 2\alpha\beta$$

$$242 = 2\alpha\beta$$

$$\Rightarrow \alpha\beta = 121$$

23. The number of ways of giving 20 distinct oranges to 3 children such that each child gets atleast one orange is \_\_\_\_\_

**Official Ans. by NTA (171)**

- Sol.** 20 distinct oranges distributed among 3 children so that each child gets at least one orange

$$= 3^{20} - {}^3C_1 2^{20} + {}^3C_2 1^{20}$$

**Bonus**

24. If the area of the region

$S = \{(x, y) : 2y - y^2 \leq x^2 \leq 2y, x \geq y\}$  is equal to

$\frac{n+2}{n+1} - \frac{\pi}{n-1}$ , then the natural number n is equal to \_\_\_\_\_

**Official Ans. by NTA (5)**

- Sol.**  $x^2 + y^2 - 2y \geq 0$  &  $x^2 - 2y \leq 0, x \geq y$

$$\text{Hence required area} = \frac{1}{2} \times 2 \times 2 - \int_0^2 \frac{x^2}{2} dx - \left( \frac{\pi}{4} - \frac{1}{2} \right)$$

$$= \frac{7}{6} - \frac{\pi}{4} \Rightarrow n = 5$$

25. Let the point  $(p, p + 1)$  lie inside the region

$E = \{(x, y) : 3 - x \leq y \leq \sqrt{9 - x^2}, 0 \leq x \leq 3\}$  If the set of

all values of p is the interval  $(a, b)$ . then  $b^2 + b - a^2$  is equal to \_\_\_\_\_

**Official Ans. by NTA (3)**

**Sol.**  $3 - x \leq y \leq \sqrt{9 - x^2}$

Points  $(p, p + 1)$  lies on  $y = x + 1$

So point of intersection between

$y = x + 1$  &  $y = 3 - x$  is  $x = 1, y = 2$

and point of intersection between

$x + 1 = \sqrt{9 - x^2}$  is  $x = \frac{-1 + \sqrt{17}}{2}$

Hence  $p \in \left(1, \frac{-1 + \sqrt{17}}{2}\right)$

Hence  $b^2 + b - a^2 = 3$

**26.** Let  $y = y(x)$  be a solution of the differential equation  $(x \cos x)dy + (x y \sin x + y \cos x - 1)dx = 0$ ,

$0 < x < \frac{\pi}{2}$ . If  $\frac{\pi}{3} y\left(\frac{\pi}{3}\right) = \sqrt{3}$ , then

$\left|\frac{\pi}{6} y''\left(\frac{\pi}{6}\right) + 2y'\left(\frac{\pi}{6}\right)\right|$  is equal to \_\_\_\_\_

**Official Ans. by NTA (2)**

**Sol.**  $(x \cos x)dy + (x y \sin x + y \cos x - 1)dx = 0, 0 < x < \frac{\pi}{2}$

$\frac{dy}{dx} + \left(\frac{x \sin x + \cos x}{x \cos x}\right)y = \frac{1}{x \cos x}$

IF =  $x \sec x$

$y \cdot x \sec x = \int \frac{x \sec x}{x \cos x} dx = \tan x + c$

Since  $y\left(\frac{\pi}{3}\right) = \frac{3\sqrt{3}}{\pi}$

Hence  $c = \sqrt{3}$

Hence  $\left|\frac{\pi}{6} y''\left(\frac{\pi}{6}\right) + y'\left(\frac{\pi}{6}\right)\right| = |-2| = 2$

**27.** The coefficient of  $x^{18}$  in the expansion of

$\left(x^4 - \frac{1}{x^3}\right)^{15}$  is \_\_\_\_\_

**Official Ans. by NTA (5005)**

**Sol.**  $\left(x^4 - \frac{1}{x^3}\right)^{15}$

$T_{r+1} = {}^{15}C_r (x^4)^{15-r} \left(\frac{-1}{x^3}\right)^r$

$60 - 7r = 18$

$r = 6$

Hence coeff. of  $x^{18} = {}^{15}C_6 = 5005$

**28.** Let  $A = \{1, 2, 3, 4, \dots, 10\}$  and  $B = \{0, 1, 2, 3, 4\}$ .

The number of elements in the relation  $R = \{(a, b)$

$\in A \times A: 2(a - b)^2 + 3(a - b) \in B\}$  is \_\_\_\_\_

**Official Ans. by NTA (18)**

**Sol.**  $A = \{1, 2, 3, \dots, 10\}$

$B = \{0, 1, 2, 3, 4\}$

$R = \{(a, b) \in A \times A: 2(a - b)^2 + 3(a - b) \in B\}$

Now  $2(a - b)^2 + 3(a - b) = (a - b)(2(a - b) + 3)$

$\Rightarrow a = b$  or  $a - b = -2$

When  $a = b \Rightarrow 10$  order pairs

When  $a - b = -2 \Rightarrow 8$  order pairs

Total = 18

**29.** Let the image of the point  $P(1, 2, 3)$  in the plane  $2x$

$- y + z = 9$  be  $Q$ . If the coordinates of the point  $R$

are  $(6, 10, 7)$ , then the square of the area of the

triangle  $PQR$  is\_

**Official Ans. by NTA (594)**

**Sol.** Let  $Q (\alpha, \beta, \gamma)$  be the image of  $P$ , about the plane

$2x - y + z = 9$

$\frac{\alpha - 1}{2} = \frac{\beta - 2}{-1} = \frac{\gamma - 3}{1} = 2$

$\Rightarrow \alpha = 5, \beta = 0, \gamma = 5$

Then area of triangle  $PQR$  is  $= \frac{1}{2} |\overline{PQ} \times \overline{PR}|$

$= |-12\hat{i} - 3\hat{j} + 21\hat{k}| = \sqrt{144 + 9 + 441} = \sqrt{594}$

Square of area = 594

30. Let the tangent to the curve  $x^2 + 2x - 4y + 9 = 0$  at the point  $P(1, 3)$  on it meet the  $y$ -axis at  $A$ . Let the line passing through  $P$  and parallel to the line  $x - 3y = 6$  meet the parabola  $y^2 = 4x$  at  $B$ . If  $B$  lies on the line  $2x - 3y = 8$ . then  $(AB)^2$  is equal to

**Official Ans. by NTA (292)**

**Sol.** Equation of tangent at  $P(1, 3)$  to the curve

$$x^2 + 2x - 4y + 9 = 0 \text{ is } y - x = 2$$

Then the point  $A$  is  $(0, 2)$

Equation of line passing through  $P$  and parallel to the line  $x - 3y = 6$ .

The possible coordinate of  $B$  are  $(4, 4)$  or  $(16, 8)$

But  $(4, 4)$  does not satisfy  $2x - 3y = 8$

Thus the point  $B$  is  $(16, 8)$

Then  $(AB)^2 = 292$



## PHYSICS

## TEST PAPER WITH SOLUTION

### SECTION-A

31. For the plane electromagnetic wave given by  $E = E_0 \sin(\omega t - kx)$  and  $B = B_0 \sin(\omega t - kx)$ , the ratio of average electric energy density to average magnetic energy density is

- (1) 1                                      (2) 1/2  
 (3) 2                                      (4) 4

**Official Ans. by NTA (1)**

**Sol.** 
$$\frac{\text{Electric energy density}}{\text{Magnetic energy density}} = \frac{\frac{1}{2} \epsilon_0 E_{\text{rms}}^2}{\left(\frac{B_{\text{rms}}^2}{2\mu_0}\right)}$$

$$= \left(\frac{E_{\text{rms}}}{B_{\text{rms}}}\right)^2 \cdot \mu_0 \epsilon_0 \quad \left[ C = \frac{1}{\mu_0 \epsilon_0} \right]$$

$$= \frac{C^2}{C^2} = 1$$

32. Name the logic gate equivalent to the diagram attached

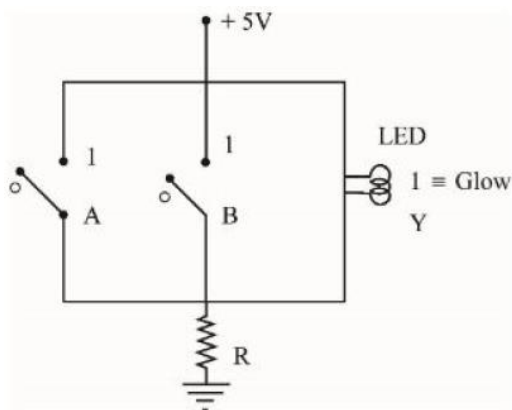

- (1) OR                                      (2) NOR  
 (3) NAND                                      (4) AND

**Official Ans. by NTA (2)**

**Sol.** Circuit is closed when neither A nor B is closed  $\Rightarrow$  current flows for  $A = 0$   $B = 0$  when either or both of A & B is closed we get current bypass from switch

Hence it is "NOR" gate

33. A small ball of mass  $M$  and density  $\rho$  is dropped in a viscous liquid of density  $\rho_0$ . After some time, the ball falls with a constant velocity. What is the viscous force on the ball ?

- (1)  $F = Mg \left(1 - \frac{\rho_0}{\rho}\right)$       (2)  $F = Mg \left(1 + \frac{\rho}{\rho_0}\right)$   
 (3)  $F = Mg \left(1 + \frac{\rho_0}{\rho}\right)$       (4)  $F = Mg(1 \pm \rho\rho_0)$

**Official Ans. by NTA (1)**

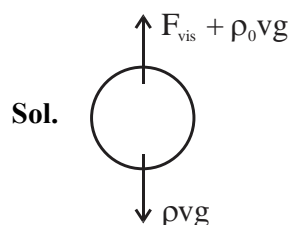

For constant velocity  $F_{\text{net}} = 0$

$$F_{\text{vis}} + \rho_0 v g = \rho v g$$

$$F_{\text{vis}} = (\rho - \rho_0) v g$$

$$= \rho v g \left(1 - \frac{\rho_0}{\rho}\right)$$

$$= Mg \left(1 - \frac{\rho_0}{\rho}\right)$$

34. The number of air molecules per  $\text{cm}^3$  increased from  $3 \times 10^{19}$  to  $12 \times 10^{19}$ . The ratio of collision frequency of air molecules before and after the increase in number respectively is

- (1) 1.25                                      (2) 0.25  
 (3) 0.75                                      (4) 0.50

**Official Ans. by NTA (2)**

**Sol.** Collision frequency,

$$f = \frac{V}{\lambda} = \frac{V}{\left(\frac{1}{\sqrt{2}\pi d^2 n_v}\right)} = \sqrt{2}\pi d^2 v n_v$$

$\therefore f \propto n_v$ ,  $n_v$  is number density

$$\frac{f_1}{f_2} = \frac{n_{v_1}}{n_{v_2}} = \frac{3 \times 10^{19}}{12 \times 10^{19}} = 0.25$$

35. A source supplies heat to a system at the rate of 1000 W. If the system performs work at a rate of 200 W. The rate at which internal energy of the system increases

- (1) 1200 W (2) 600 W  
(3) 500 W (4) 800 W

**Official Ans. by NTA (4)**

**Sol.**  $dQ = dU + dw$

$$\frac{dU}{dt} = \frac{dQ}{dt} - \frac{dw}{dt}$$

$$\frac{dU}{dt} = 1000 - 200 = 800 \text{ W}$$

36. A particle is moving with constant speed in a circular path. When the particle turns by an angle  $90^\circ$ , the ratio of instantaneous velocity to its average velocity is  $\pi : x\sqrt{2}$ . The value of x will be

- (1) 2 (2) 5  
(3) 1 (4) 7

**Official Ans. by NTA (1)**

**Sol.**

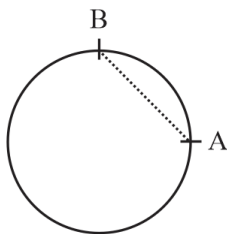

$$AB = R\sqrt{2}$$

Let instantaneous velocity be v. time,

$$t = \frac{\text{Arc length}}{v} = \frac{2\pi \frac{R}{4}}{v} = \frac{\pi R}{2v}$$

average velocity,

$$\langle v \rangle = \frac{AB}{t} = \frac{R\sqrt{2}(2v)}{\pi R} = \frac{2\sqrt{2}v}{\pi}$$

$$\Rightarrow \frac{V}{\langle V \rangle} = \frac{\pi}{2\sqrt{2}}$$

37. A small block of mass 100 g is tied to a spring of spring constant 7.5 N/m and length 20 cm. The other end of spring is fixed at a particular point A. If the block moves in a circular path on a smooth horizontal surface with constant angular velocity 5 rad/s about point A, then tension in the spring is

- (1) 1.5 N (2) 0.75 N  
(3) 0.25 N (4) 0.50 N

**Official Ans. by NTA (2)**

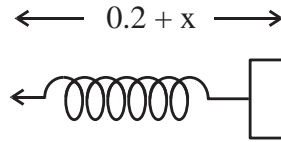

**Sol.**

$$kx \leftarrow \square \rightarrow m\omega^2 r$$

Let extension in length of spring be x.

Radius of circle  $r = 0.2 + x$

$$Kx = m\omega^2 r$$

$$7.5x = \left(\frac{1}{10}\right)(5^2)(0.2 + x)$$

$$\Rightarrow \frac{15}{2}x = \frac{5}{2}\left(x + \frac{1}{5}\right)$$

$$\Rightarrow x = \frac{1}{10}$$

$$\therefore \text{Tension in spring} = kx = 7.5 \times \frac{1}{10} = 0.75 \text{ N}$$

38. A monochromatic light wave with wavelength  $\lambda_1$  and frequency  $\nu_1$  in air enters another medium. If the angle of incidence and angle of refraction at the interface are  $45^\circ$  and  $30^\circ$  respectively, then the wavelength  $\lambda_2$  and frequency  $\nu_2$  of the refracted wave are :

$$(1) \lambda_2 = \lambda_1, \nu_2 = \sqrt{2}\nu_1 \quad (2) \lambda_2 = \frac{1}{\sqrt{2}}\lambda_1, \nu_2 = \nu_1$$

$$(3) \lambda_2 = \sqrt{2}\lambda_1, \nu_2 = \nu_1 \quad (4) \lambda_2 = \lambda_1, \nu_2 = \frac{1}{\sqrt{2}}\nu_1$$

**Official Ans. by NTA (2)**

**Sol.**

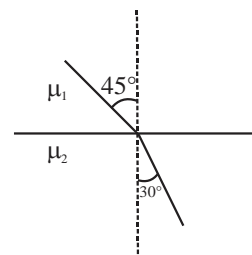

Snell's law  $\mu_1 \sin 45^\circ = \mu_2 \sin 30^\circ$

$$\frac{\mu_1}{\mu_2} = \frac{1}{\sqrt{2}}$$

$$\Rightarrow \frac{\mu_1}{\mu_2} = \frac{\lambda_2}{\lambda_1} = \frac{1}{\sqrt{2}}$$

$$\Rightarrow \lambda_2 = \frac{\lambda_1}{\sqrt{2}}$$

Frequency doesn't change on change in medium.

39. Given below are two statements : one is labelled as **Assertion A** and the other is labelled as **Reason R**.  
**Assertion A** : When a body is projected at an angle  $45^\circ$ , its range is maximum.

**Reason R** : For maximum range, the value of  $\sin 2\theta$  should be equal to one.

In the light of the above statements, choose the **correct** answer from the options given below :

(1) Both **A** and **R** are correct but **R** is **NOT** the correct explanation of **A**

(2) Both **A** and **R** are correct **R** is the correct explanation of **A**

(3) **A** is true but **R** is false

(4) **A** is false but **R** is true

**Official Ans. by NTA (2)**

**Sol.**  $R = \frac{u^2}{g} \sin 2\theta$

R is maximum for  $2\theta = 90^\circ$ .

40. Two resistances are given as  $R_1 = (10 \pm 0.5)\Omega$  and  $R_2 = (15 \pm 0.5)\Omega$ . The percentage error in the measurement of equivalent resistance when they are connected in parallel is

(1) 6.33 (2) 2.33

(3) 4.33 (4) 5.33

**Official Ans. by NTA (3)**

**Sol.**  $\frac{1}{R} = \frac{1}{R_1} + \frac{1}{R_2}$

Differentiating both sides, we get

$$\frac{\Delta R}{R^2} = \frac{\Delta R_1}{R_1^2} + \frac{\Delta R_2}{R_2^2} \left[ R = \frac{R_1 R_2}{R_1 + R_2} = \frac{10 \times 15}{10 + 15} = 6 \right]$$

$$\Rightarrow \frac{\Delta R}{R} = \left( \frac{\Delta R_1}{R_1^2} + \frac{\Delta R_2}{R_2^2} \right) R$$

$$= \left( \frac{0.5}{100} + \frac{0.5}{225} \right) 6$$

$$= \left( \frac{6 \times 0.5}{25} \right) \left( \frac{1}{4} + \frac{1}{9} \right) = \frac{13}{300}$$

$$\frac{\Delta R}{R} \times 100 = \frac{13}{3} = 4.33\%$$

41. A planet has double the mass of the earth. Its average density is equal to the that of the earth. An object weighing W on earth will weigh on that planet :

(1)  $2^{2/3} W$

(2) W

(3)  $2^{1/3} W$

(4) 2 W

**Official Ans. by NTA (3)**

**Sol.**  $m = \rho \times \frac{4}{3} \pi R^3$

$$R \propto m^{1/3} (\rho = \text{constant})$$

$$\text{weight} = W \propto g \propto \frac{Gm}{R^2}$$

$$W \propto \frac{m}{m^{2/3}} \propto m^{1/3}$$

$$\text{So, } W^1 = (2)^{1/3} W$$

42. Given below are two statements : one is labelled as **Assertion A** and the other is labelled as **Reason R**.

**Assertion A** : Earth has atmosphere whereas moon doesn't have any atmosphere.

**Reason R** : The escape velocity on moon is very small as compared to that on earth.

In the light of the above statement, choose the **correct** answer from the options given below :

(1) A is true but R is false

(2) A is false but R is true

(3) Both A and R are correct but R is **NOT** the correct explanation of A

(4) Both A and R are correct and R is correct explanation of A

**Official Ans. by NTA (4)**

**Sol.** At Moon, due to low escape velocity, the rms velocity of molecules is greater than escape velocity. Hence molecules escape and there is no atmosphere at Moon.

**43.** For a uniformly charged thin spherical shell, the electric potential (V) radially away from the center (O) of shell can be graphically represented as

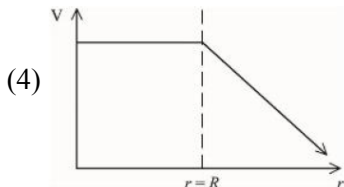
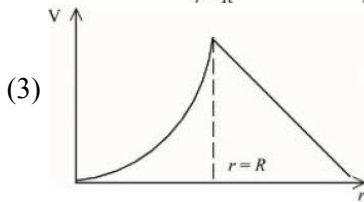
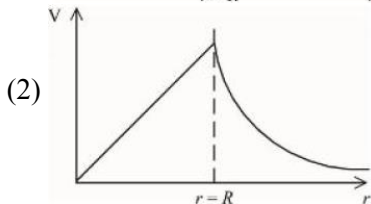
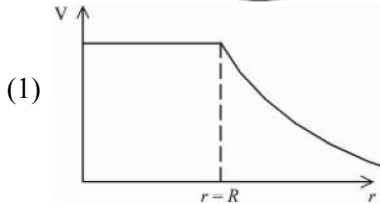
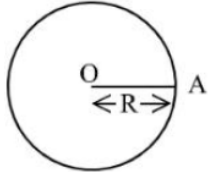

**Official Ans. by NTA (1)**

**Sol.**

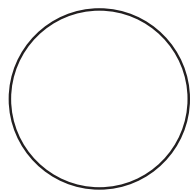

$$V_{\text{inside}} = \frac{kQ}{R}$$

$$V_{\text{outside}} = \frac{kQ}{r}$$

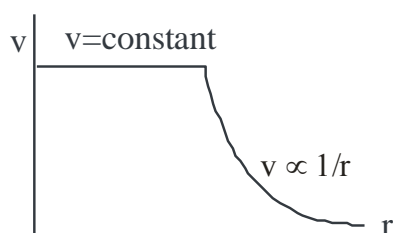

**44.** The resistivity ( $\rho$ ) of semiconductor varies with temperature. Which of the following curve represents the correct behaviour

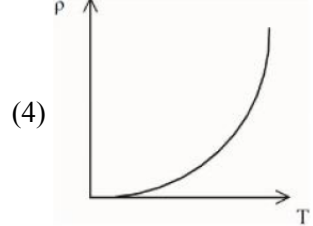
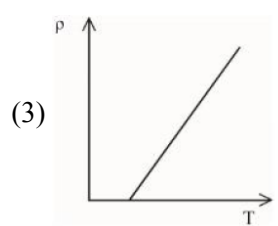
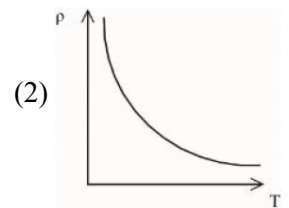
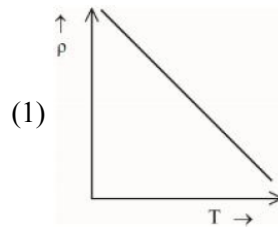

**Official Ans. by NTA (2)**

**Sol.**

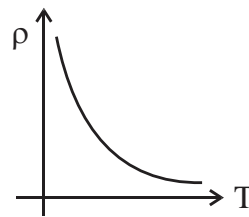

$$\rho = \frac{m}{ne^2\tau}$$

With rise in temperature, number density (n) of electrons and holes increases for semiconductors.

As m, e,  $\tau$  are constant

$$\rho \propto \frac{1}{n} \Rightarrow \rho \propto \frac{1}{T} \text{ [Rectangular hyperbola]}$$

**45.** The kinetic energy of an electron,  $\alpha$ -particle and a proton are given as 4K, 2K and K respectively. The de-Broglie wavelength associated with electron ( $\lambda_e$ )  $\alpha$ -particle ( $\lambda_\alpha$ ) and the proton ( $\lambda_p$ ) are as follows :

(1)  $\lambda_\alpha = \lambda_p < \lambda_e$

(2)  $\lambda_\alpha > \lambda_p > \lambda_e$

(3)  $\lambda_\alpha < \lambda_p < \lambda_e$

(4)  $\lambda_\alpha = \lambda_p > \lambda_e$

**Official Ans. by NTA (3)**

	Electron	Alpha	Proton
Mass :	$\frac{m}{1840}$	4m	m
Charge :	e	2e	e
Kinetic energy	4K	2K	K
$\lambda = \frac{h}{\sqrt{2mK}}$	$\frac{h}{\sqrt{2 \cdot \frac{m}{1840} \cdot 4K}}$	$\frac{h}{\sqrt{2 \cdot 4m \cdot 2K}}$	$\frac{h}{\sqrt{2mK}}$

Sol.

$$\lambda_\alpha < \lambda_p < \lambda_e$$

46. By what percentage will the transmission range of a TV tower be affected when the height of the tower is increased by 21% ?

- (1) 14% (2) 12%  
(3) 10% (4) 15%

Official Ans. by NTA (3)

Sol. Range,  $R = \sqrt{2Rh}$

$$R_1 = \sqrt{2Rh_1}$$

$$h_2 = h_1 + \left( h_1 \times \frac{21}{100} \right) = 1.21h_1$$

$$\therefore R_2 = \sqrt{2Rh_2} = \sqrt{2R(1.21)h_1} = 1.1\sqrt{2Rh_1}$$

$$\therefore R_2 = 1.1 R_1$$

% increase in range

$$= \frac{R_2 - R_1}{R_1} \times 100 = \left( \frac{R_2}{R_1} - 1 \right) \times 100$$

$$= (1.1 - 1) \times 100 = 10\%$$

47. The energy levels of an hydrogen atom are shown below. The transition corresponding to emission of shortest wavelength is

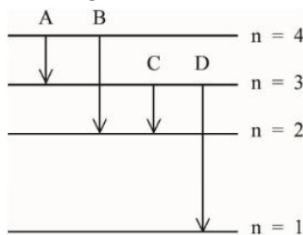

- (1) C (2) D  
(3) B (4) A

Official Ans. by NTA (2)

Sol.  $\Delta E = \frac{hc}{\lambda} \Rightarrow \lambda \propto \frac{1}{\Delta E}$

For shortest wavelength, energy gap should be maximum.

So, correct choice is transition from  $n = 3$  to  $n = 1$ .

48. A mass  $m$  is attached to two springs as shown in figure. The spring constants of two springs are  $K_1$  and  $K_2$ . For the frictionless surface, the time period of oscillation of mass  $m$  is

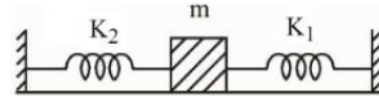

(1)  $\frac{1}{2\pi} \sqrt{\frac{K_1 + K_2}{m}}$

(2)  $\frac{1}{2\pi} \sqrt{\frac{K_1 - K_2}{m}}$

(3)  $2\pi \sqrt{\frac{m}{K_1 + K_2}}$

(4)  $2\pi \sqrt{\frac{m}{K_1 - K_2}}$

Official Ans. by NTA (3)

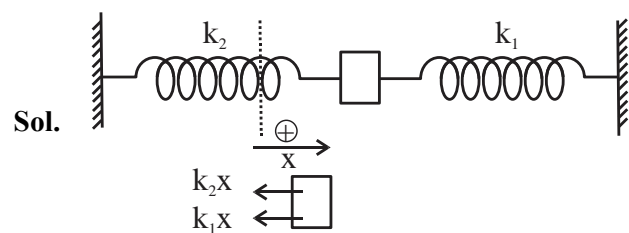

On displacing  $m$  to right by  $x$

$$F = -(k_1x + k_2x) = -(k_1 + k_2)x$$

$$a = \frac{F}{m} = -\left( \frac{k_1 + k_2}{m} \right) x = -\omega^2 x$$

$$\therefore \omega = \sqrt{\frac{k_1 + k_2}{m}} \Rightarrow T = \frac{2\pi}{\omega} = 2\pi \sqrt{\frac{m}{k_1 + k_2}}$$

49. The induced emf can be produced in a coil by
- A. moving the coil with uniform speed inside magnetic field  
B. moving the coil with non-uniform speed inside uniform magnetic field  
C. rotating the coil inside the uniform magnetic field  
D. changing the area of the coil inside the uniform magnetic field

Choose the correct answer from the options given below:

- (1) B and D only (2) B and C only  
(3) A and C only (4) C and D only

Official Ans. by NTA (4)

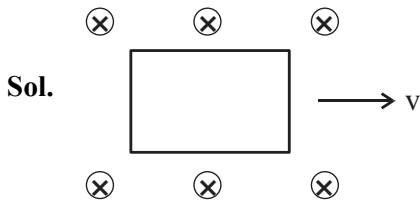

Moving a coil inside a uniform magnetic field either with uniform or non-uniform speed doesn't change flux, so, no emf is induced.

50. A long straight wire of circular cross-section (radius  $a$ ) is carrying steady current  $I$ . The current  $I$  is uniformly distributed across this cross-section. The magnetic field is

- (1) Zero in the region  $r < a$  and inversely proportional to  $r$  in the region  $r > a$
- (2) Inversely proportional to  $r$  in the region  $r < a$  and uniform throughout in the region  $r > a$
- (3) Directly proportional to  $r$  in the region  $r < a$  and inversely proportional to  $r$  in the region  $r > a$
- (4) Uniform in the region  $r < a$  and inversely proportional to distance  $r$  from the axis, in the region  $r > a$

**Official Ans. by NTA (3)**

Sol.

$$B = \begin{cases} \frac{\mu_0 I r}{\pi a^2} & r \leq a \\ \frac{\mu_0 I}{\pi r} & r \geq a \end{cases}$$

### SECTION-B

51. A pole is vertically submerged in swimming pool, such that it gives a length of shadow 2.15 m within water when sunlight is incident at an angle of  $30^\circ$  with the surface of water. If swimming pool is filled to a height of 1.5 m, then the height of the pole above the water surface in centimetres is ( $n_w = 4/3$ ) \_\_\_\_\_.

**Official Ans. by NTA (50)**

Sol.

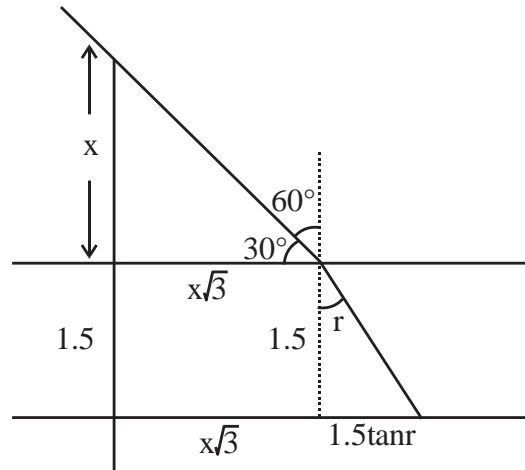

By Snell's law

$$1 \sin 60^\circ = \frac{4}{3} \sin r \rightarrow \sin r = \frac{3\sqrt{3}}{8} \rightarrow \tan r = \frac{3\sqrt{3}}{\sqrt{37}}$$

By the diagram

$$x\sqrt{3} + 1.5 \tan r = 2.15$$

$$x\sqrt{3} = 2.15 - 1.5 \times \frac{3\sqrt{3}}{\sqrt{37}}$$

$$x = \frac{2.15}{\sqrt{3}} - \frac{1.5 \times 3}{\sqrt{37}}$$

$$= 1.241 - 0.739$$

$$= 0.502$$

$$\approx 0.50 \text{ meter}$$

$$x = 50 \text{ cm}$$

52. The length of a metallic wire is increased by 20% and its area of cross section is reduced by 4%. The percentage change in resistance of the metallic wire is \_\_\_\_\_.

**Official Ans. by NTA (25)**

Sol.  $R = \rho \frac{\ell}{A}$  be the initial resistance new resistance

$$R' = \rho \frac{1.2\ell}{0.96A} = 1.25\rho \frac{\ell}{A} = 1.25R$$

$$\text{percentage change} = \frac{1.25R - R}{R} \times 100 = 25\%$$

53. A particle of mass 10 g moves in a straight line with retardation  $2x$ , where  $x$  is the displacement in SI units. Its loss of kinetic energy for above displacement is  $\left(\frac{10}{x}\right)^{-n}$  J. The value of  $n$  will be \_\_\_\_\_.

**Official Ans. by NTA (2)**

**Sol.** Loss of K.E = work done against retarding force.

$$\begin{aligned} &= \int_0^x m a dx = \int_0^x m 2x dx = mx^2 \\ &= (10^{-2} \text{ kg}) x^2 \text{ J} = \left(\frac{10}{x}\right)^{-2} \text{ J} \end{aligned}$$

So  $n = 2$

54. Two identical circular wires of radius 20 cm and carrying current  $\sqrt{2}$  A are placed in perpendicular planes as shown in figure. The net magnetic field at the centre of the circular wire is \_\_\_\_\_  $\times 10^{-8}$  T. (Take  $\pi = 3.14$ )

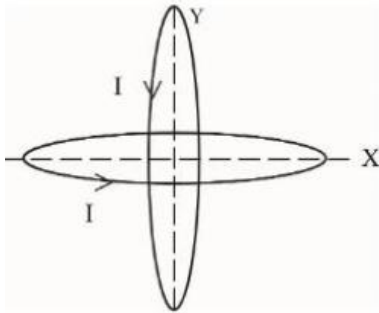

**Official Ans. by NTA (628)**

**Sol.** Magnetic field  $B_C$  at center  $= \frac{\mu_0 i}{2r}$

$$= \frac{4\pi \times 10^{-7}}{2 \times 0.2} \times \sqrt{2} \text{ T}$$

Net magnetic field is

$$\begin{aligned} B_C \sqrt{2} &= \frac{4\pi \times 10^{-7} \times \sqrt{2}}{2 \times 0.2} \times \sqrt{2} \text{ T} = 2\pi \times 10^{-6} \text{ T} \\ &= 200\pi \times 10^{-8} \text{ T} \\ &= 2 \times 314 \times 10^{-8} \text{ T} \\ &= 628 \times 10^{-8} \text{ T} \end{aligned}$$

55. A person driving car at a constant speed of 15 m/s is approaching a vertical wall. The person notices a change of 40 Hz in the frequency of his car's horn upon reflection from the wall. The frequency of horn is \_\_\_\_\_ Hz.

(Given : Speed of sound : 330 m/s)

**Official Ans. by NTA (420)**

**Sol.** Frequency of reflected sound  $= \left(\frac{v + v_c}{v - v_c}\right) f_0$

$$f = \left(\frac{330 + 15}{330 - 15}\right) \times f_0$$

$$= \frac{345}{315} f_0$$

$$\frac{345}{315} f_0 - f_0 = 40$$

$$\frac{30}{315} f_0 = 40$$

$$f_0 = \frac{4 \times 315}{3} = 420 \text{ Hz}$$

56. The radius of fifth orbit of the  $\text{Li}^{++}$  is \_\_\_\_\_  $\times 10^{-12}$  m. Take : radius of hydrogen atom =  $0.51 \text{ \AA}$

**Official Ans. by NTA (425)**

**Sol.**  $r_n = r_0 \frac{n^2}{Z} \rightarrow r_n = 0.51 \times \frac{25}{3} \text{ \AA} = 4.25 \times 10^{-10} \text{ m}$

$$= 425 \times 10^{-12} \text{ m}$$

57. A steel rod has a radius of 20 mm and a length of 2.0 m. A force of 62.8 kN stretches it along its length. Young's modulus of steel is  $2.0 \times 10^{11} \text{ N/m}^2$ . The longitudinal strain produced in the wire is \_\_\_\_\_  $\times 10^{-5}$

**Official Ans. by NTA (25)**

**Sol.** Strain =  $\frac{\text{stress}}{Y} = \frac{62.8 \times 10^3}{\pi \times (0.02)^2 \times 2 \times 10^{11}}$

$$= \frac{62.8 \times 10^3}{3.14 \times 4 \times 10^{-4} \times 2 \times 10^{11}}$$

$$= 2.5 \times 10^{-4}$$

$$= 25 \times 10^{-5}$$

- 58.** An ideal transformer with purely resistive load operates at 12 kV on the primary side. It supplies electrical energy to a number of nearby houses at 120 V. The average rate of energy consumption in the houses served by the transformer is 60 kW. The value of resistive load ( $R_s$ ) required in the secondary circuit will be \_\_\_\_\_  $m\Omega$ .

**Official Ans. by NTA (240)**

**Sol.**  $v_p = 12 \times 10^3$  volts  
 $v_s = 120$  volts  
 $p_s = 60 \text{ KW} = v_s \times i_s$

$$i_s = \frac{60 \times 10^3}{120} = 5 \times 10^2 \text{ A}$$

$$R_L = \frac{v_s}{i_s} = \frac{120}{5 \times 10^2} = 24 \times 10^{-2} = 240 \times 10^{-3} \Omega$$

$$= 240 \text{ m}\Omega$$

- 59.** Two identical solid spheres each of mass 2 kg and radii 10 cm are fixed at the ends of a light rod. The separation between the centres of the spheres is 40 cm. The moment of inertia of the system about an axis perpendicular to the rod passing through its middle point is \_\_\_\_\_  $\times 10^{-3} \text{ kg-m}^2$

**Official Ans. by NTA (176)**

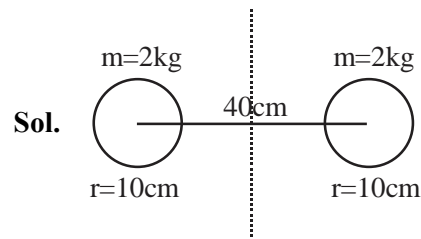

$$I = 2(I_{cm} + md^2)$$

$$= 2\left(\frac{2}{5}mr^2 + md^2\right)$$

$$= \frac{4}{5} \times 2 \times (0.1)^2 + 2(2)(0.20)^2$$

$$= \frac{8}{5} \times 10^{-2} + 16 \times 10^{-2}$$

$$= (1.6 + 16) \times 10^{-2}$$

$$= 17.6 \times 10^{-2}$$

$$I = 176 \times 10^{-3} \text{ kg m}^2$$

- 60.** A parallel plate capacitor with plate area  $A$  and plate separation  $d$  is filled with a dielectric material of dielectric constant  $K = 4$ . The thickness of the dielectric material is  $x$ , where  $x < d$ .



Let  $C_1$  and  $C_2$  be the capacitance of the system for  $x = \frac{1}{3}d$  and  $x = \frac{2d}{3}$ , respectively. If  $C_1 = 2\mu\text{F}$  the value of  $C_2$  is \_\_\_\_\_  $\mu\text{F}$

**Official Ans. by NTA (3)**

**Sol.** For  $x = \frac{d}{3}$

$$C_1 = \frac{\epsilon_0 A}{\left(\frac{d/3}{k} + \frac{2d}{3}\right)} = \frac{\epsilon_0 A}{\frac{d}{12} + \frac{2d}{3}}$$

$$= \frac{\epsilon_0 A}{d} \times \left(\frac{12}{9}\right)$$

$$C_1 = \frac{4}{3} \frac{\epsilon_0 A}{d} = 2\mu\text{F}$$

for  $x = \frac{2d}{3}$

$$C_2 = \frac{\epsilon_0 A}{\left(\frac{2d/3}{k} + \frac{d}{3}\right)} = \frac{\epsilon_0 A}{d} \times 2$$

$$\Rightarrow \frac{6}{4} \times 2 = 3\mu\text{F}$$



## CHEMISTRY

## TEST PAPER WITH SOLUTION

### SECTION-A

61. A compound is formed by two elements X and Y. The element Y forms cubic close packed arrangement and those of element X occupy one third of the tetrahedral voids. What is the formula of the compound?

- (1)  $X_2Y_3$
- (2)  $X_3Y$
- (3)  $X_3Y_2$
- (4)  $XY_3$

**Official Ans. by NTA (1)**

**Sol.** Y : CCP  $\Rightarrow$  4Y

$$X = \frac{1}{3} \text{ THV} = \frac{1}{3} \times 8 \Rightarrow \frac{8}{3}x$$

$\therefore$  Formula :  $X_{8/3}Y_4$  or  $X_2Y_3$

62. Match List I with List II

List I		List II	
Element detected		Reagent used/ Product formed	
A	Nitrogen	I.	$\text{Na}_2[\text{Fe}(\text{CN})_5 \text{NO}]$
B	Sulphur	II.	$\text{AgNO}_3$
C	Phosphorous	III.	$\text{Fe}_4[\text{Fe}(\text{CN})_6]_3$
D	Halogen	IV.	$(\text{NH}_4)_2 \text{MoO}_4$

Choose the correct answer from the options given below:

- (1) A-II, B-IV, C-I, D-III
- (2) A-IV, B-II, C-I, D-III
- (3) A-II, B-I, C-IV, D-III
- (4) A-III, B-I, C-IV, D-II

**Official Ans. by NTA (4)**

Nitrogen detection by lassaigne's method

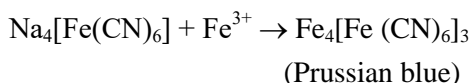
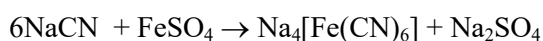

Sulphur detection by Sodium nitroprusside

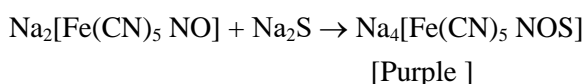

Phosphorus detection by ammonium molybdate

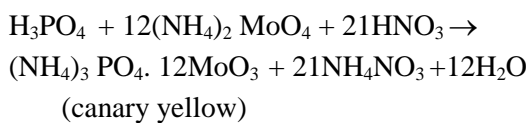
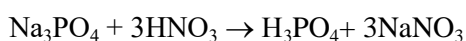

Halogen give specific coloured ppt with  $\text{AgNO}_3(\text{aq})$

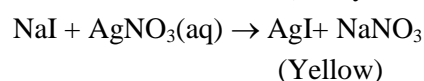
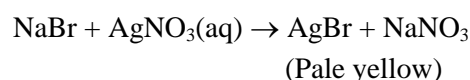
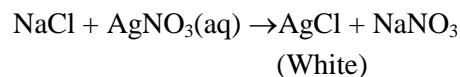

63. The standard electrode potential of  $M^+/M$  in aqueous solution does not depend on

- (1) Ionisation of a solid metal atom
- (2) Sublimation of a solid metal
- (3) Ionisation of a gaseous metal atom
- (4) Hydration of a gaseous metal ion

**Official Ans. by NTA (1)**

**Sol.** Factual

64. Polymer used in orlon is:

- (1) Polyacrylonitrile
- (2) Polyethene
- (3) Polycarbonate
- (4) Polyamide

**Official Ans. by NTA (1)**

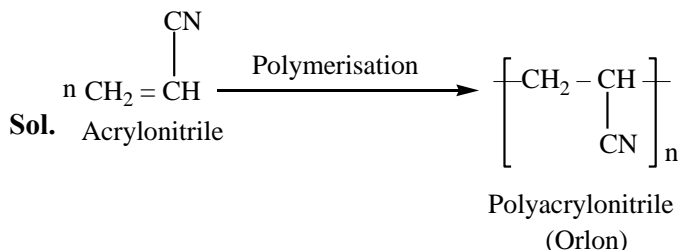

65. The difference between electron gain enthalpies will be maximum between:

- (1) Ne and F
- (2) Ne and Cl
- (3) Ar and Cl
- (4) Ar and F

**Official Ans. by NTA (2)**

**Sol.** Cl has the most negative  $\Delta H_{\text{eg}}$  among all the elements and Ne has the most positive  $\Delta H_{\text{eg}}$ .

66. Match List I with List II

List I Enzymatic reaction		List II Enzyme	
A	Sucrose → Glucose and Fructose	I.	Zymase
B	Glucose → ethyl alcohol and CO <sub>2</sub>	II.	Pepsin
C	Starch → Maltose	III.	Invertase
D	Proteins → Amino acids	IV.	Diastase

Choose the correct answer from the options given below:

- (1) A-III, B-I, C-II, D-IV
- (2) A-I, B-IV, C-III, D-II
- (3) A-III, B-I, C-IV, D-II
- (4) A-I, B-II, C-IV, D-III

**Official Ans. by NTA (3)**

**Sol.** Factual

67. The possibility of photochemical smog formation is more at

- (1) The places with healthy vegetation
- (2) Himalayan villages in winter
- (3) Marshy lands
- (4) Industrial areas

**Official Ans. by NTA (4)**

**Sol.** Photochemical smog occurs in warm, dry and sunny climate. The main components come from the action of sunlight on unsaturated hydrocarbon and nitrogen oxides produced by automobiles and factories.

68. The setting time of Cement is increased by adding

- (1) Clay
- (2) Silica
- (3) Limestone
- (4) Gypsum

**Official Ans. by NTA (4)**

**Sol.** Factual

69. Given below are two statements: one is labelled as assertion and the other is labelled as reason .

**Assertion:** Loss of electron from hydrogen atom results in nucleus of  $\sim 1.5 \times 10^{-3}$  pm size.

**Reason:** Proton (H<sup>+</sup>) always exists in combined form

In the light of the above statements, choose the most appropriate answer from the options given below:

- (1) Both A and R are correct and R is the correct explanation of A
- (2) A is correct but R is not correct
- (3) A is not correct but R is correct
- (4) Both A and R are correct but R is NOT the correct explanation of A.

**Official Ans. by NTA (4)**

**Sol.** Factual

70.

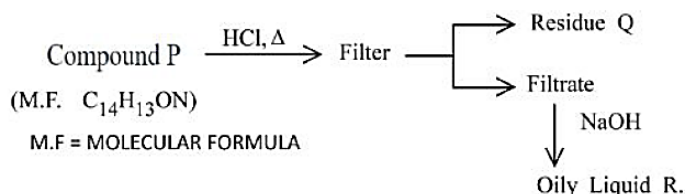

Compound P is neutral. Q gives effervescence with NaHCO<sub>3</sub> while R reacts with Hinsbergs reagent to give solid soluble in NaOH. Compound P is

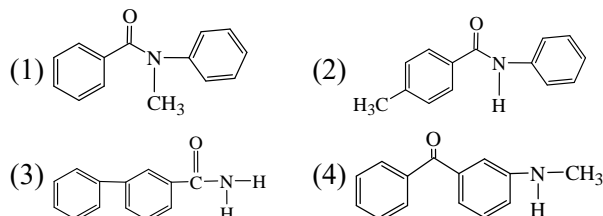

**Official Ans. by NTA (2)**

**Sol.**

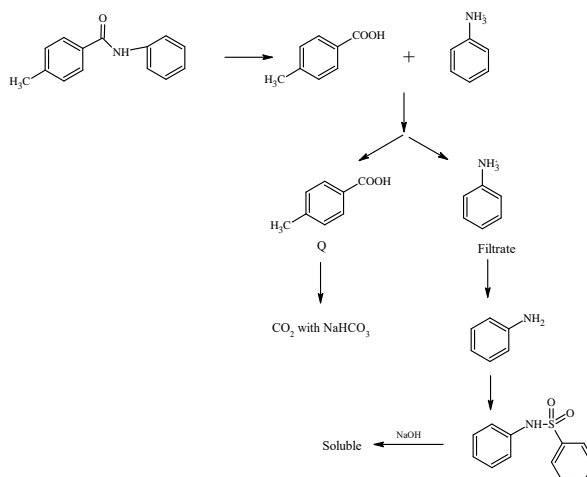

71. Match List I with List II

List I		List II	
Name of reaction		Reagent used	
A	Hell-Volhard-Zelinsky reaction	I.	NaOH + I <sub>2</sub>
B	Iodoform reaction	II.	(i) CrO <sub>2</sub> Cl <sub>2</sub> , CS <sub>2</sub> (ii) H <sub>2</sub> O
C	Etard reaction	III.	(i) Br <sub>2</sub> /red phosphorus (ii) H <sub>2</sub> O
D	Gatterman-Koch reaction	IV.	CO, HCl, anhyd. AlCl <sub>3</sub>

Choose the correct answer from the options given below:

- (1) A-III, B-II, C-I, D-IV
- (2) A-III, B-I, C-IV, D-II
- (3) A-I, B-II, C-III, D-IV
- (4) A-III, B-I, C-II, D-IV

Official Ans. by NTA (4)

Sol. HVZ reactions = Br<sub>2</sub> / red P

Iodoform reaction = NaOH + I<sub>2</sub>

Etard reaction = (i) CrO<sub>2</sub> Cl<sub>2</sub>, CS<sub>2</sub>(ii) H<sub>2</sub>O

Gatterman-Koch Reaction = CO, HCl, Anhydrous, AlCl<sub>3</sub>

72. The major products A and B from the following reactions are:

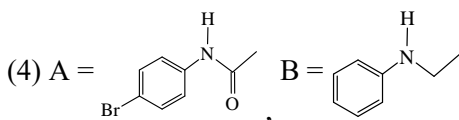
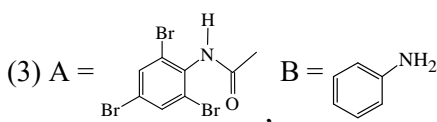
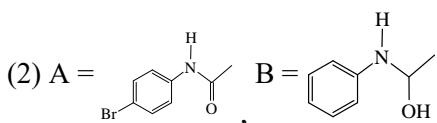
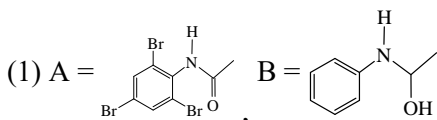
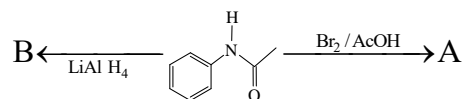

Official Ans. by NTA (4)

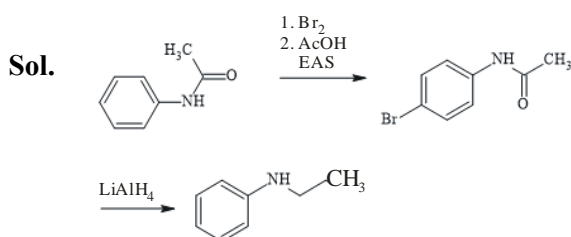

73. Given below are two statements, one is labelled as **Assertion A** and the other is labelled as **Reason R**. **Assertion A:** The spin only magnetic moment value for [Fe(CN)<sub>6</sub>]<sup>3-</sup> is 1.74 BM, whereas for [Fe(H<sub>2</sub>O)<sub>6</sub>]<sup>3+</sup> is 5.92 BM.

**Reason R :** In both complexes, Fe is present in +3 oxidation state.

In the light of the above statements, choose the correct answer from the options given below:

- (1) Both A and R are true but R is NOT the correct explanation of A
- (2) A is false but R is true
- (3) A is true but R is false
- (4) Both A and R are true and R is the correct explanation of A

Official Ans. by NTA (1)

Sol. [Fe(CN)<sub>6</sub>]<sup>3-</sup>

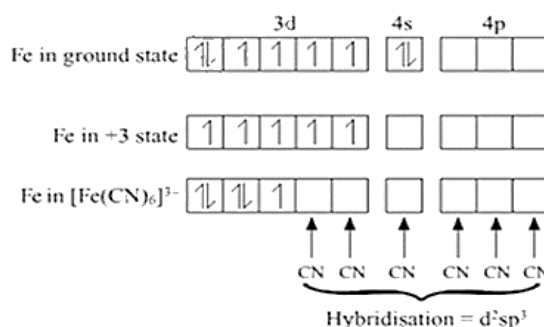

Unpaired electron = 1

$$\mu = \sqrt{n(n+2)} = \sqrt{1 \times 3} = 1.74 \text{ B.M.}$$

[Fe(H<sub>2</sub>O)<sub>6</sub>]<sup>3+</sup> No pairing because H<sub>2</sub>O is WFL

Number of unpaired electrons = 5,  $\mu = 5.92 \text{ BM}$

Assertion is true, Reason is true but not correct explanation.

74. Match List I with List II

List I Vitamin		List II Deficiency disease	
A	Vitamin A	I.	Beri-Beri
B	Thiamine	II.	Cheilosis
C	Ascorbic acid	III.	Xerophthalmia
D	Riboflavin	IV.	Scurvy

Choose the correct answer from the options given below:

- (1) A-IV, B-II, C-III, D-I
- (2) A-III, B-II, C-IV, D-I
- (3) A-IV, B-I, C-III, D-II
- (4) A-III, B-I, C-IV, D-II

Official Ans. by NTA (4)

Sol. Factual

75. Which of the following options are correct for the reaction

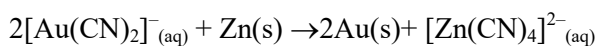

- A. Redox reaction  
 B. Displacement reaction  
 C. Decomposition reaction  
 D. Combination reaction

Choose the correct answer from the options given below:

- (1) A and B only                      (2) A only  
 (3) C and D only                      (4) A and D only

**Official Ans. by NTA (1)**

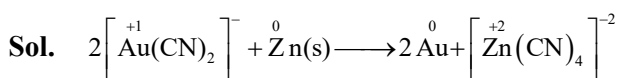

Zn displaced  $\text{Au}^+$

Reduction and Oxidation both are taking place.

76. Match List I with List II

List I Oxide		List II Type of Bond	
A	$\text{N}_2\text{O}_4$	I.	1N = O bond
B	$\text{NO}_2$	II.	1N - O - N bond
C	$\text{N}_2\text{O}_5$	III.	1N - N bond
D	$\text{N}_2\text{O}$	IV.	1N = N / N $\equiv$ N bond

Choose the correct answer from the options given below:

- (1) A-II, B-IV, C-III, D-I  
 (2) A-II, B-I, C-III, D-IV  
 (3) A-III, B-I, C-IV, D-II  
 (4) A-III, B-I, C-II, D-IV

**Official Ans. by NTA (4)**

**Sol.**  $\text{N}_2\text{O}_4$

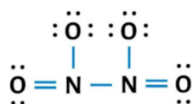

$\text{NO}_2$

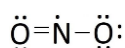

$\text{N}_2\text{O}_5$

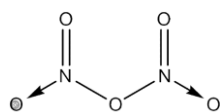

$\text{N}_2\text{O}$

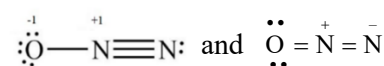

77. Strong reducing and oxidizing agents among the following, respectively, are

- (1)  $\text{Ce}^{4+}$  and  $\text{Eu}^{2+}$                       (2)  $\text{Ce}^{4+}$  and  $\text{Tb}^{4+}$   
 (3)  $\text{Ce}^{3+}$  and  $\text{Ce}^{4+}$                       (4)  $\text{Eu}^{2+}$  and  $\text{Ce}^{4+}$

**Official Ans. by NTA (4)**

**Sol. Factual**

78. The major product formed in the following reaction is

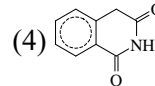
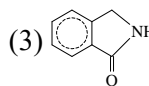
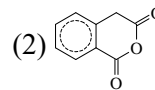
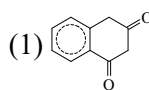
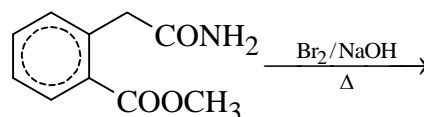

**Official Ans. by NTA (3)**

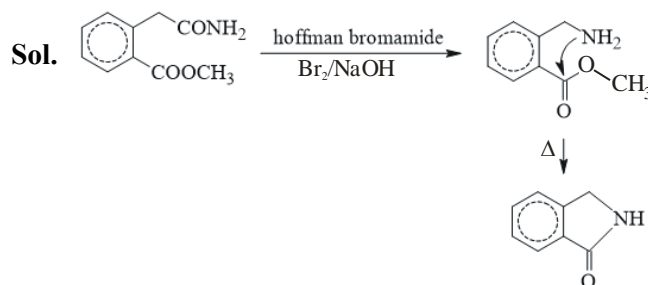

79. For a concentrated solution of a weak electrolyte ( $K_{\text{eq}}$  = equilibrium constant)  $\text{A}_2\text{B}_3$  of concentration 'c', the degree of dissociation ' $\alpha$ ' is

- (1)  $\left(\frac{K_{\text{eq}}}{108c^4}\right)^{\frac{1}{5}}$                       (2)  $\left(\frac{K_{\text{eq}}}{6c^5}\right)^{\frac{1}{5}}$   
 (3)  $\left(\frac{K_{\text{eq}}}{5c^4}\right)^{\frac{1}{5}}$                       (4)  $\left(\frac{K_{\text{eq}}}{25c^2}\right)^{\frac{1}{5}}$

**Official Ans. by NTA (1)**

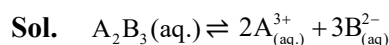

$$c(1-\alpha) \quad 2c\alpha \quad 3c\alpha$$

$$K_{\text{eq}} = \frac{[\text{A}^{3+}]^2 [\text{B}^{2-}]^3}{[\text{A}_2\text{B}_3]} = \frac{4c^2\alpha^2 \times 27c^3\alpha^3}{c(1-\alpha)}$$

$$K_{\text{eq}} = \frac{108c^5\alpha^5}{c} \quad \alpha = \left(\frac{K_{\text{eq}}}{108c^4}\right)^{\frac{1}{5}}$$

80. For the reaction:

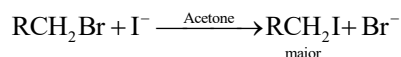

The correct statement is :

- (1) The transition state formed in the above reaction is less polar than the localised anion.
- (2) The reaction can occur in acetic acid also.
- (3) The solvent used in the reaction solvates the ions formed in rate determining step.
- (4)  $\text{Br}^-$  can act as competing nucleophile.

**Official Ans. by NTA (1)**

Sol. This is finkelstein reaction

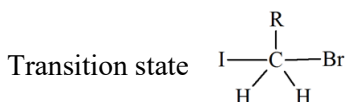
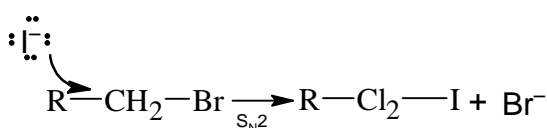

Clearly, the transition state is less polar than free anions.  $\text{Br}^-$  and  $\text{I}^-$

Acetic acid is protic which does not support  $\text{S}_{\text{N}}2$

Acetone does not solvate anion

$\text{Br}^-$  gets precipitated and hence can not compete with  $\text{I}^-$

So only (1) is correct

### SECTION-B

81. The wavelength of an electron of kinetic energy  $4.50 \times 10^{-29} \text{ J}$  is.....  $\times 10^{-5} \text{ m}$ . (Nearest integer)

Given : mass of electron is  $9 \times 10^{-31} \text{ kg}$ ,  $h = 6.6 \times 10^{-34} \text{ J s}$

**Official Ans. by NTA (7)**

Sol.

$$\lambda_d = \frac{h}{mv} = \frac{h}{\sqrt{2mKE}} = \frac{6.6 \times 10^{-34}}{\sqrt{2 \times 9 \times 10^{-31} \times 4.5 \times 10^{-29}}}$$

$$= \frac{6.6 \times 10^{-34}}{\sqrt{9^2 \times 10^{-60}}}$$

$$= \frac{6.6 \times 10^{-34}}{9 \times 10^{-30}} = \frac{6.6}{9} \times 10^{-4}$$

$$= 7.3 \times 10^{-5} \text{ m}$$

Therefore Ans = 7

82. Number of bromo derivatives obtained on treating ethane with excess of  $\text{Br}_2$ , in diffused sunlight is...

**Official Ans. by NTA (9)**

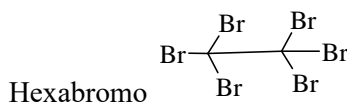
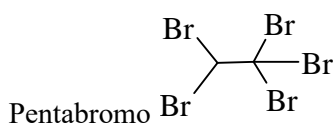
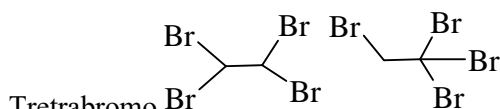
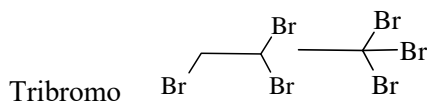
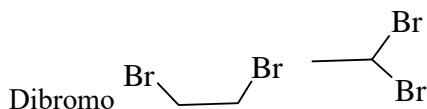
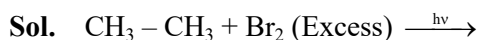

83. Consider the graph of Gibbs free energy  $G$  vs Extent of reaction. The number of statement/s from the following which are true with respect to points (a), (b) and (c) is.....

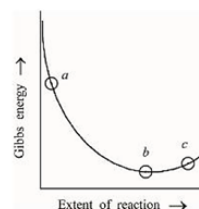

- A. Reaction is spontaneous at (a) and (b)
- B. Reaction is at equilibrium at point (b) and non-spontaneous at point (c)
- C. Reaction is spontaneous at (a) and non-spontaneous at (c)
- D. Reaction is non-spontaneous at (a) and (b)

**Official Ans. by NTA (2)**

Sol. For, Spontaneous process  $dG < 0$   
 For, Equilibrium  $dG = 0$   
 For, Nonspontaneous process  $dG > 0$   
 $\therefore$  A Wrong  
 B Correct  
 C Correct  
 D Wrong

84. Mass of Urea ( $\text{NH}_2\text{CONH}_2$ ) required to be dissolved in 1000 g of water to reduce the vapour pressure of water by 25% is.....g. (Nearest integer)

Given: Molar mass of N, C, O and H are 14, 12, 16 and 1  $\text{mol}^{-1}$  respectively.

**Official Ans. by NTA (1111)**

**Sol.** 
$$\frac{P^0 - P_s}{P_s} = \frac{n_{\text{solute}}}{n_{\text{solvent}}} = \frac{\frac{x}{60}}{\frac{1000}{18}} = \frac{P^0 - 0.75P^0}{0.75P^0}$$

$$\Rightarrow x = \frac{10000}{9} = 1111 \text{ gm}$$

Ans: 1111

85. The value of  $\log K$  for the reaction  $\text{A} \rightleftharpoons \text{B}$  at 298 K is ..... (Nearest integer)

Given:  $\Delta H^0 = -54.07 \text{ kJ mol}^{-1}$

$\Delta S^0 = 10 \text{ JK}^{-1} \text{ mol}^{-1}$

(Take  $2.303 \times 8.314 \times 298 = 5705$ )

**Official Ans. by NTA (10)**

**Sol.**  $\Delta G^0 = \Delta H^0 - T\Delta S$

$$\Rightarrow \Delta G^0 = (-54070 - 10 \times 298)$$

Also,  $\Delta G^0 = (-2.303 RT \log K)$

$$\Rightarrow (-54070 - 10 \times 298) = (-2.303 \times 8.314 \times 298 \log K)$$

$$\Rightarrow \log K = 10 \quad \text{Ans: 10}$$

86. The number of species from the following which have square pyramidal structure is

$\text{PF}_5$ ,  $\text{BrF}_4^-$ ,  $\text{IF}_5$ ,  $\text{BrF}_5$ ,  $\text{XeOF}_4$ ,  $\text{ICl}_4^-$

**Official Ans. by NTA (3)**

**Sol.**  $\text{PF}_5$   
 $\text{sp}^3\text{d}$  (0 lone pair)  
 Trigonal bipyramidal

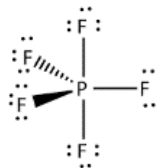

$\text{BrF}_4^-$ ,  
 $\text{sp}^3\text{d}^2$  (2 lone pair)

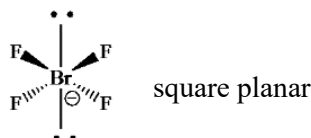

$\text{IF}_5$   
 $\text{sp}^3\text{d}^2$  (1 lone pair)

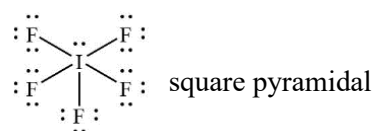

$\text{BrF}_5$   
 $\text{sp}^3\text{d}^2$  (1 lone pair)  
 square pyramidal

$\text{XeOF}_4$   
 $\text{sp}^3\text{d}^2$  (1 lone pair)  
 square pyramidal

$\text{ICl}_4^-$   
 $\text{sp}^3\text{d}^2$  (2 lone pair)  
 square planar

87. Number of ambidentate ligands in a representative metal complex  $[\text{M}(\text{en})(\text{SCN})_4]$  is  
 [en = ethylenediamine]

**Official Ans. by NTA (4)**

**Sol.**  $[\text{M}(\text{en})(\text{SCN})_4]$

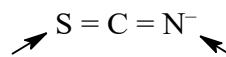

Ambidentate ligand means two ligand site, so ambidentate ligand is  $\text{SCN}^-$ .

Ans: 4

88. For the adsorption of hydrogen on platinum, the activation energy is  $30 \text{ kJ mol}^{-1}$  and for the adsorption of hydrogen on nickel, the activation energy is  $41.4 \text{ kJ mol}^{-1}$ . The logarithm of the ratio of the rates of chemisorption on equal areas of the metals at  $300 \text{ K}$  is ..... (Nearest integer)

Given:  $\ln 10 = 2.3$        $R = 8.3 \text{ JK}^{-1} \text{ mol}^{-1}$

**Official Ans. by NTA (2)**

**Sol.**  $K = Ae^{-\frac{E_a}{RT}}$   
 $K_1 = Ae^{-\frac{(E_a)_1}{RT}}$   
 $K_2 = Ae^{-\frac{(E_a)_2}{RT}}$   
 $\frac{K_2}{K_1} = e^{-\frac{(E_a)_1 - (E_a)_2}{RT}}$   
 $\log \frac{K_2}{K_1} = \frac{(E_a)_1 - (E_a)_2}{2.3RT}$   
 $= \frac{(41.4 - 30) \times 1000}{2.3 \times 8.3 \times 300} = 1.99$

Ans: 2

89. If 5 moles of  $\text{BaCl}_2$  is mixed with 2 moles of  $\text{Na}_3\text{PO}_4$ , the maximum number of moles of  $\text{Ba}_3(\text{PO}_4)_2$  formed is.....

(Nearest integer)

**Official Ans. by NTA (1)**

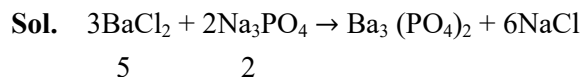

$\text{Na}_3\text{PO}_4$  is limiting reagent.

2 mole  $\text{Na}_3\text{PO}_4$  gives 1 mole of  $\text{Ba}_3(\text{PO}_4)_2$

Ans: 1

90. In ammonium-phosphomolybdate, the oxidation state of Mo is + .....

**Official Ans. by NTA (6)**

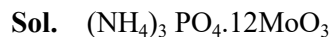

Let X = oxidation state of Mo in  $\text{MoO}_3$

$$X + (-2) \times 3 = 0$$

$$X = + 6$$

Ans: 6