

FINAL JEE–MAIN EXAMINATION – APRIL, 2023

(Held On Tuesday 11th April, 2023)

TIME : 9 : 00 AM to 12 : 00 NOON

MATHEMATICS

TEST PAPER WITH SOLUTION

SECTION-A

1. The value of the integral

$$\int_{-\log_e 2}^{\log_e 2} e^x \left(\log_e (e^x + \sqrt{1+e^{2x}}) \right) dx \text{ is equal to}$$

(1) $\log_e \left(\frac{2(2+\sqrt{5})}{\sqrt{1+\sqrt{5}}} \right) - \frac{\sqrt{5}}{2}$

(2) $\log_e \left(\frac{\sqrt{2}(3-\sqrt{5})^2}{\sqrt{1+\sqrt{5}}} \right) + \frac{\sqrt{5}}{2}$

(3) $\log_e \left(\frac{(2+\sqrt{5})^2}{\sqrt{1+\sqrt{5}}} \right) + \frac{\sqrt{5}}{2}$

(4) $\log_e \left(\frac{\sqrt{2}(2+\sqrt{5})^2}{\sqrt{1+\sqrt{5}}} \right) - \frac{\sqrt{5}}{2}$

Official Ans. by NTA (4)

Sol. $I = \int_{-\ln 2}^{\ln 2} e^x \left(\ln (e^x + \sqrt{1+e^{2x}}) \right) dx$

Put $e^x = t \Rightarrow e^x dx = dt$

$$I = \int_{1/2}^2 \ln (t + \sqrt{1+t^2}) dt$$

Applying integration by parts.

$$= \left[t \ln (t + \sqrt{1+t^2}) \right]_{1/2}^2 - \int_{1/2}^2 \frac{t}{t + \sqrt{1+t^2}} \left(1 + \frac{2t}{2\sqrt{1+t^2}} \right) dt$$

$$= 2 \ln (2 + \sqrt{5}) - \frac{1}{2} \ln \left(\frac{1 + \sqrt{5}}{2} \right) - \int_{1/2}^2 \frac{t}{\sqrt{1+t^2}} dt$$

$$= 2 \ln (2 + \sqrt{5}) - \frac{1}{2} \ln \left(\frac{1 + \sqrt{5}}{2} \right) - \frac{\sqrt{5}}{2}$$

$$= \ln \left(\frac{(2 + \sqrt{5})^2}{\left(\frac{\sqrt{5} + 1}{2} \right)^{\frac{1}{2}}} \right) - \frac{\sqrt{5}}{2}$$

2. If equation of the plane that contains the point $(-2, 3, 5)$ and is perpendicular to each of the planes $2x + 4y + 5z = 8$ and $3x - 2y + 3z = 5$ is

$$\alpha x + \beta y + \gamma z + 97 = 0 \text{ then } \alpha + \beta + \gamma =$$

(1) 18

(2) 17

(3) 16

(4) 15

Official Ans. by NTA (4)

Sol. The equation of plane through $(-2, 3, 5)$ is

$$a(x+2) + b(y-3) + c(z-5) = 0$$

it is perpendicular to $2x+4y+5z=8$ & $3x-2y+3z=5$

$$\therefore 2a + 4b + 5c = 0$$

$$3a - 2b + 3c = 0$$

$$\therefore \frac{a}{\begin{vmatrix} 4 & 5 \\ -2 & 3 \end{vmatrix}} = \frac{-b}{\begin{vmatrix} 2 & 5 \\ 3 & 3 \end{vmatrix}} = \frac{c}{\begin{vmatrix} 2 & 4 \\ 3 & -2 \end{vmatrix}}$$

$$\Rightarrow \frac{a}{22} = \frac{b}{9} = \frac{c}{-16}$$

\therefore Equation of Plane is

$$22(x+2) + 9(y-3) - 16(z-5) = 0$$

$$\Rightarrow 22x + 9y - 16z + 97 = 0$$

Comparing with $\alpha x + \beta y + \gamma z + 97 = 0$

We get $\alpha + \beta + \gamma = 22 + 9 - 16 = 15$

3. Let R be a rectangle given by the lines $x = 0$, $x = 2$, $y = 0$ and $y = 5$. Let $A(\alpha, 0)$ and $B(0, \beta)$, $\alpha \in [0, 2]$ and $\beta \in [0, 5]$, be such that the line segment AB divides the area of the rectangle R in the ratio 4:1.

Then, the mid-point of AB lies on a

- (1) parabola
- (2) hyperbola
- (3) straight line
- (4) circle

Official Ans. by NTA (2)

Sol. $\frac{\text{ar}(\text{OPQR})}{\text{or}(\text{OAB})} = \frac{4}{1}$

Let M be the mid-point of AB.

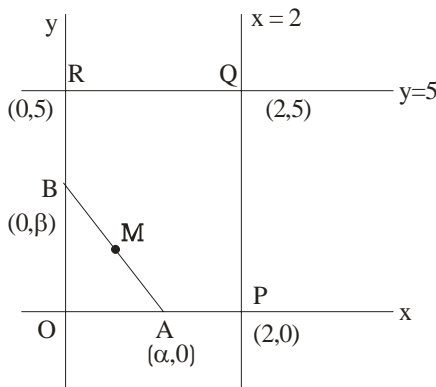

$$M(h, k) \equiv \left(\frac{\alpha}{2}, \frac{\beta}{2} \right)$$

$$\Rightarrow \frac{10 - \frac{1}{2}\alpha\beta}{\frac{1}{2}\alpha\beta} = 4$$

$$\Rightarrow \frac{5}{2}\alpha\beta = 10 \Rightarrow \alpha\beta = 4$$

$$\Rightarrow (2h)(2k) = 4$$

\therefore Locus of M is $xy = 1$

Which is a hyperbola.

4. Let sets A and B have 5 elements each. Let the mean of the elements in sets A and B be 5 and 8 respectively and the variance of the elements in sets A and B be 12 and 20 respectively. A new set C of 10 elements is formed by subtracting 3 from each element of A and adding 2 to each element of B. Then the sum of the mean and variance of the elements of C is _____.

- (1) 32
- (2) 38
- (3) 40
- (4) 36

Official Ans. by NTA (2)

Sol. ω $A = \{a_1, a_2, a_3, a_4, a_5\}$

$$B = \{b_1, b_2, b_3, b_4, b_5\}$$

Given, $\sum_{i=1}^5 a_i = 25$, $\sum_{i=1}^5 b_i = 40$

$$\frac{\sum_{i=1}^5 a_i^2}{5} - \left(\frac{\sum_{i=1}^5 a_i}{5} \right)^2 = 12, \quad \frac{\sum_{i=1}^5 b_i^2}{5} - \left(\frac{\sum_{i=1}^5 b_i}{5} \right)^2 = 20$$

$$\Rightarrow \sum_{i=1}^5 a_i^2 = 185, \quad \sum_{i=1}^5 b_i^2 = 420$$

Now, $C = \{C_1, C_2, \dots, C_{10}\}$

s.f. $C_i = a_i - 3$ or $b_i + 2$
First five elements Last five elements

$$\therefore \text{Mean of C, } \bar{C} = \frac{(\sum a_i - 15) + (\sum b_i + 10)}{10}$$

$$\bar{C} = \frac{10 + 50}{10} = 6$$

$$\therefore \sigma^2 = \frac{\sum_{i=1}^{10} C_i^2}{10} = (\bar{C})^2$$

$$= \frac{\sum (a_i - 3)^2 + \sum (b_i + 2)^2}{10} - (6)^2$$

$$= \frac{\sum a_i^2 + \sum b_i^2 - 6\sum a_i + 4\sum b_i + 65}{10} - 36$$

$$= \frac{185 + 420 - 150 + 160 + 65}{10} - 36$$

$$= 32$$

$$\therefore \text{Mean + Variance} = \bar{C} + \sigma^2 = 6 + 32 = 38$$

5. Let $f(x) = x^2 - x + |-x + [x]|$, where $x \in \mathbb{R}$ and $[t]$ denotes the greatest integer less than or equal to t . Then, f is
- (1) continuous at $x = 0$, but not continuous at $x = 1$
 - (2) continuous at $x = 0$ and $x = 1$
 - (3) not continuous at $x = 0$ and $x = 1$
 - (4) continuous at $x = 1$, but not continuous at $x = 0$
- Official Ans. by NTA (4)**

Sol. Here $f(x) = [x(x-1)] + \{x\}$

$f(0^+) = -1 + 0 = -1$	$f(1^+) = 0 + 0 = 0$
$f(0) = 0$	$f(1) = 0$
	$f(1^-) = -1 + 1 = 0$

- $\therefore f(x)$ is continuous at $x = 1$, discontinuous at $x = 0$
6. The number of triplets (x, y, z) , where x, y, z are distinct non negative integers satisfying $x + y + z = 15$, is
- (1) 80
 - (2) 114
 - (3) 92
 - (4) 136
- Official Ans. by NTA (2)**

Sol. $x + y + z = 15$

$$\text{Total no. of solution} = {}^{15+3-1}C_{3-1} = 136 \quad \dots(1)$$

Let $x = y \neq z$

$$2x + z = 15 \Rightarrow z = 15 - 2t$$

$$\Rightarrow r \in \{0, 1, 2, \dots, 7\} - \{5\}$$

\therefore 7 solutions

\therefore there are 21 solutions in which exactly

Two of x_1, y_1, z are equal $\dots(2)$

There is one solution in which $x=y=z$ $\dots(3)$

$$\text{Required answer} = 136 - 21 - 1 = 114$$

7. For any vector $a = a_1\hat{i} + a_2\hat{j} + a_3\hat{k}$, with $10|a_i| < 1, i = 1, 2, 3$, consider the following statements:
- (A) : $\max\{|a_1|, |a_2|, |a_3|\} \leq |\vec{a}|$
- (B) : $|\vec{a}| \leq 3 \max\{|a_1|, |a_2|, |a_3|\}$
- (1) Only (B) is true
 - (2) Only (A) is true
 - (3) Neither (A) nor (B) is true
 - (4) Both (A) and (B) are true
- Official Ans. by NTA (4)**

Sol. Without loss of generality

$$\text{Let } |a_1| \leq |a_2| \leq |a_3|$$

$$|\vec{a}|^2 = |a_1|^2 + |a_2|^2 + |a_3|^2 \geq (a_3)^2$$

$$\Rightarrow |\vec{a}| \geq |a_3| = \max\{|a_1|, |a_2|, |a_3|\}$$

A is true

$$|\vec{a}|^2 = |a_1|^2 + |a_2|^2 + |a_3|^2 \leq |a_3|^2 + |a_3|^2 + |a_3|^2$$

$$\Rightarrow |\vec{a}|^2 \leq 3|a_3|^2$$

$$\Rightarrow |\vec{a}| \leq \sqrt{3}|a_3| = \sqrt{3} \max\{|a_1|, |a_2|, |a_3|\}$$

$$\leq 3 \max\{|a_1|, |a_2|, |a_3|\}$$

(2) is true

8. Let w_1 be the point obtained by the rotation of $z_1 = 5 + 4i$ about the origin through a right angle in the anticlockwise direction, and w_2 be the point obtained by the rotation of $z_2 = 3 + 5i$ about the origin through a right angle in the clockwise direction. Then the principal argument of $w_1 - w_2$ is equal to

$$(1) -\pi + \tan^{-1} \frac{33}{5}$$

$$(2) -\pi - \tan^{-1} \frac{33}{5}$$

$$(3) -\pi + \tan^{-1} \frac{8}{9}$$

$$(4) \pi - \tan^{-1} \frac{8}{9}$$

Official Ans. by NTA (4)

Sol. $W_1 = z_1 i = (5 + 4i)i = -4 + 5i \quad \dots(i)$

$W_2 = z_2 (-i) = (3 + 5i)(-i) = 5 - 3i \quad \dots(2)$

$W_1 - W_2 = -9 + 8i$

Principal argument = $\pi - \tan^{-1}\left(\frac{8}{9}\right)$

9. An organization awarded 48 medals in event 'A', 25 in event 'B' and 18 in event 'C'. If these medals went to total 60 men and only five men got medals in all the three events, then, how many received medals in exactly two of three events?

(1) 10

(2) 9

(3) 21

(4) 15

Official Ans. by NTA (3)

Sol. $|A| = 48$

$|B| = 25$

$|C| = 18$

$|A \cup B \cup C| = 60 \quad [\text{Total}]$

$|A \cap B \cap C| = 5$

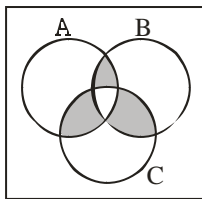

$|A \cup B \cup C| = \sum |A| - \sum |A \cap B| + |A \cap B \cap C|$

$\Rightarrow \sum |A \cap B| = 48 + 25 + 18 + 5 - 60$

$= 36$

No. of men who received exactly 2 medals

$= \sum |A \cap B| - 3|A \cap B \cap C|$

$= 36 - 15$

$= 21$

10. Let $S = \{M = [a_{ij}], a_{ij} \in \{0,1,2\}, 1 \leq i, j \leq 2\}$ be a sample space and $A = \{M \in S : M \text{ is invertible}\}$ be an event. Then $P(A)$ is equal to

(1) $\frac{50}{81}$

(2) $\frac{47}{81}$

(3) $\frac{49}{81}$

(4) $\frac{16}{27}$

Official Ans. by NTA (1)

Sol. $M \begin{bmatrix} a & b \\ c & d \end{bmatrix}$, where $a, b, c, d, \in \{0,1,2\}$

$n(s) = 3^4 = 81$

we first bound $p(\bar{A})$

$|m| = 0 \Rightarrow ad = bc$

$ad = bc = 0 \Rightarrow \text{no. of } (a,b,c,d) = (3^2 - 2^2)^2 = 25$

$ad = bc = 1 \Rightarrow \text{no. of } (a,b,c,d) = 1^2 = 1$

$ad = bc = 2 \Rightarrow \text{no. of } (a,b,c,d) = 2^2 = 4$

$ad = bc = 4 \Rightarrow \text{no. of } (a,b,c,d) = 1^2 = 1$

$\therefore P(\bar{A}) = \frac{31}{81} \Rightarrow P(A) = \frac{50}{81}$

11. Consider ellipses $E_k : kx^2 + k^2y^2 = 1, k = 1, 2, \dots,$

20. Let C_k be the circle which touches the four chords joining the end points (one on minor axis and another on major axis) of the ellipse E_k . If r_k is

the radius of the circle C_k , then the value of $\sum_{k=1}^{20} \frac{1}{r_k^2}$

is

(1) 3080

(2) 3210

(3) 3320

(4) 2870

Official Ans. by NTA (1)

Sol. $Kx^2 + K^2y^2 = 1$

$$\frac{x^2}{1/K} + \frac{y^2}{1/K^2} = 1$$

Now

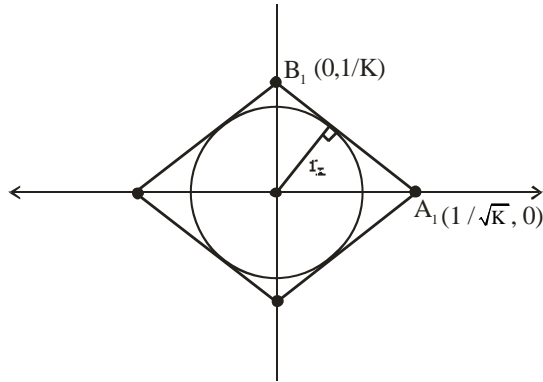

Equation of

$$A_1B_2; \frac{x}{1/\sqrt{K}} + \frac{y}{1/K} = 1 \Rightarrow \sqrt{K}x + Ky = 1$$

$r_k = \perp r$ distance of $(0,0)$ from line A_1B_1

$$r_k = \frac{|(0+0-1)|}{\sqrt{K+K^2}} = \frac{1}{\sqrt{K+K^2}}$$

$$\frac{1}{r_k^2} = K + K^2 \Rightarrow \sum_{k=1}^{20} \frac{1}{r_k^2} = \sum_{k=1}^{20} (K + K^2)$$

$$= \sum_{K=1}^{20} K + \sum_{K=1}^{20} K^2$$

$$= \frac{20 \times 21}{2} + \frac{20 \cdot 21 \cdot 41}{6}$$

$$= 210 + 10 \times 7 \times 41$$

$$= 210 + 2870$$

$$= 3080$$

12. The number of integral solutions x of

$$\log_{x+\frac{7}{2}} \left(\frac{x-7}{2x-3} \right)^2 \geq 0 \text{ is}$$

(1) 6 (2) 8

(3) 5 (4) 7

Official Ans. by NTA (1)

Sol. $\log_{x+\frac{7}{2}} \left(\frac{x-7}{2x-3} \right)^2 \geq 0$

Feasible region : $x + \frac{7}{2} > 0 \Rightarrow x > -\frac{7}{2}$

And $x + \frac{7}{2} \neq 1 \Rightarrow x \neq -\frac{5}{2}$

And $\frac{x-7}{2x-3} \neq 0$ and $2x-3 \neq 0$

\Downarrow

$$x \neq 7$$

\Downarrow

$$x \neq \frac{3}{2}$$

Taking intersection : $x \in \left(\frac{-7}{2}, \infty \right) - \left\{ -\frac{5}{2}, \frac{3}{2}, 7 \right\}$

Now $\log_a b \geq 0$ if $a > 1$ and $b \geq 1$

Or

$$a \in (0,1) \text{ and } b \in (0,1)$$

C-I; $x + \frac{7}{2} > 1$ and $\left(\frac{x-7}{2x-3} \right)^2 \geq 1$

$$x > -\frac{5}{2} \quad (2x-3)^2 - (x-7)^2 \leq 0$$

$$(2x-3+x-7)(2x-3-x+7) \leq 0$$

$$(3x-10)(x+4) \leq 0$$

$$x \in \left[-4, \frac{10}{3} \right]$$

Intersection : $x \in \left(\frac{-5}{2}, \frac{10}{3} \right]$

C-II $x + \frac{7}{2} \in (0,1)$ and $\left(\frac{x-7}{2x-3} \right)^2 \in (0,1)$

$$0 < x + \frac{7}{2} < 1 \quad \left(\frac{x-7}{2x-3} \right)^2 < 1$$

$$-\frac{7}{2} < x < -\frac{5}{2} \quad (x-7)^2 < (2x-3)^2$$

$$x \in (-\infty, -4) \cup \left(\frac{10}{3}, \infty \right)$$

No common values of x .

Hence intersection with feasible region

We get $x \in \left(\frac{-5}{2}, \frac{10}{3} \right] - \left\{ \frac{3}{2} \right\}$

Integral value of x are $\{-2, -1, 0, 1, 2, 3\}$

No. of integral values = 6

13. Area of the region $\{(x, y): x^2 + (y - 2)^2 \leq 4, x^2 \geq 2y\}$ is

- (1) $2\pi - \frac{16}{3}$ (2) $\pi - \frac{8}{3}$
 (3) $\pi + \frac{8}{3}$ (4) $2\pi + \frac{16}{3}$

Official Ans. by NTA (1)

Sol. $x^2 + (y - 2)^2 \leq 2^2$ and $x^2 \geq 2y$

Solving circle and parabola simultaneously :

$$2y + y^2 - 4y + 4 = 4$$

$$y^2 - 2y = 0$$

$$y = 0, 2$$

$$\text{Put } y = 2 \text{ in } x^2 = 2y \rightarrow x = \pm 2$$

$$\Rightarrow (2, 2) \text{ and } (-2, 2)$$

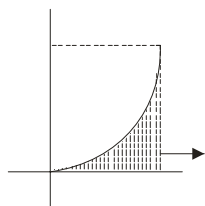
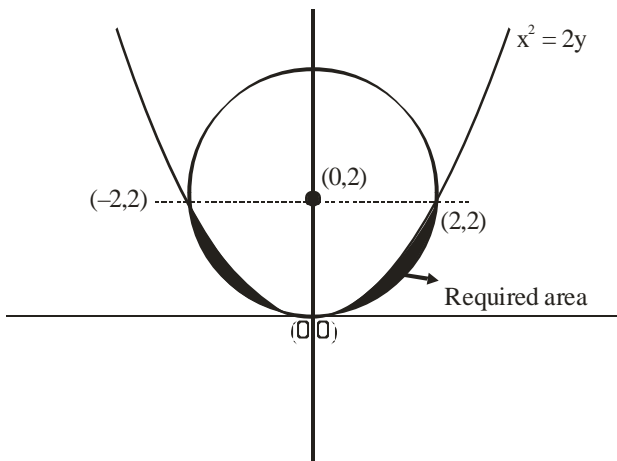

$$= 2 \times 2 - \frac{1}{4} \cdot \pi \cdot 2^2 = 4 - \pi$$

$$\text{Required area} = 2 \left[\int_0^2 \frac{x^2}{2} dx - (4 - \pi) \right]$$

$$= 2 \left[\frac{x^3}{6} \Big|_0^2 - 4 + \pi \right]$$

$$= 2 \left[\frac{4}{3} + \pi - 4 \right]$$

$$= 2 \left[\pi - \frac{8}{3} \right]$$

$$= 2\pi - \frac{16}{3}$$

14. Let $f : [2, 4] \rightarrow \mathbb{R}$ be a differentiable function such that $(x \log_e x) f'(x) + (\log_e x) f(x) + f(x) \geq 1$,

$$x \in [2, 4] \text{ with } f(2) = \frac{1}{2} \text{ and } f(4) = \frac{1}{4}.$$

Consider the following two statements:

$$(A) : f(x) \leq 1, \text{ for all } x \in [2, 4]$$

$$(B) : f(x) \geq \frac{1}{8}, \text{ for all } x \in [2, 4]$$

Then,

- (1) Only statement (B) is true
 (2) Neither statement (A) nor statement (B) is true
 (3) Both the statement (A) and (B) are true
 (4) Only statement (A) is true

Official Ans. by NTA (3)

Sol. $x \ln x f'(x) + \ln x f(x) + f(x) \geq 1, x \in [2, 4]$

$$\text{And } f(2) = \frac{1}{2}, f(4) = \frac{1}{4}$$

$$\text{Now } x \ln x \frac{dy}{dx} + (\ln + 1)y \geq 1$$

$$\frac{d}{dx} (y \cdot x \ln x) \geq 1$$

$$\frac{d}{dx} (f(x) \cdot x \ln x) \geq 1$$

$$\Rightarrow \frac{d}{dx} (x \ln x f(x) - x) \geq 0, x \in [2, 4]$$

\Rightarrow The function $g(x) = x \ln x f(x) - x$ is increasing in $[2, 4]$

$$\text{And } g(2) = 2 \ln 2 f(2) - 2 = \ln 2 - 2$$

$$g(4) = 4 \ln 4 f(4) - 4 = \ln 4 - 4 \\ = 2(\ln 2 - 2)$$

$$\text{Now } g(2) \leq g(x) \leq g(4)$$

$$\ln 2 - 2 \leq x \ln x f(x) - x \leq 2(\ln 2 - 2)$$

$$\frac{\ln 2 - 2}{x \ln x} + \frac{1}{\ln x} \leq f(x) \leq \frac{2(\ln 2 - 2)}{x \ln x} + \frac{1}{\ln x}$$

Now for $x \in [2, 4]$

$$\frac{2(\ln 2 - 2)}{x \ln x} + \frac{1}{\ln x} < \frac{2(\ln 2 - 2)}{2 \ln 2} + \frac{1}{\ln 2} = 1 - \frac{1}{\ln 2} < 1$$

$$\Rightarrow f(x) \leq 1 \text{ for } x \in [2, 4]$$

Also for $x \in [2, 4]$:

$$\frac{\ln 2 - 2}{x \ln x} + \frac{1}{\ln x} \geq \frac{\ln 2 - 2}{4 \ln 4} + \frac{1}{\ln 4} = \frac{1}{8} + \frac{1}{2 \ln 2} > \frac{1}{8}$$

$$\Rightarrow f(x) \geq \frac{1}{8} \text{ for } x \in [2, 4]$$

Hence both A and B are true.

LMVT on $(yx (\ln x))$ not satisfied.

Hence no such function exists.

Therefore it should be bonus.

15. Let $y = y(x)$ be a solution curve of the differential equation, $(1 - x^2 y^2) dx = y dx + x dy$.

If the line $x = 1$ intersects the curve $y = y(x)$ at $y = 2$ and the line $x = 2$ intersects the curve $y = y(x)$ at $y = \alpha$, then a value of α is

(1) $\frac{3e^2}{2(3e^2 - 1)}$

(2) $\frac{3e^2}{2(3e^2 + 1)}$

(3) $\frac{1 - 3e^2}{2(3e^2 + 1)}$

(4) $\frac{1 + 3e^2}{2(3e^2 - 1)}$

Official Ans. by NTA (4)

Sol. $(1 - x^2 y^2) dx = y dx + x dy, y(1) = 2$

$$y(2) = \alpha = ?$$

$$dx = \frac{d(xy)}{1 - (xy)^2}$$

$$\int dx = \int \frac{d(xy)}{1 - (xy)^2}$$

$$x = \frac{1}{2} \ln \left| \frac{1 + xy}{1 - xy} \right| + C$$

Put $x = 1$ and $y = 2$:

$$1 = \frac{1}{2} \ln \left| \frac{1 + 2}{1 - 2} \right| + C$$

$$C = 1 - \frac{1}{2} \ln 3$$

Now put $x = 2$:

$$2 = \frac{1}{2} \ln \left| \frac{1 + 2\alpha}{1 - 2\alpha} \right| + 1 - \frac{1}{2} \ln 3$$

$$1 + \frac{1}{2} \ln 3 = \frac{1}{2} \ln \left| \frac{1 + 2\alpha}{1 - 2\alpha} \right|$$

$$2 + \ln 3 = \ln \left(\frac{1 + 2\alpha}{1 - 2\alpha} \right)$$

$$\left| \frac{1 + 2\alpha}{1 - 2\alpha} \right| = 3e^2$$

$$\frac{1 + 2\alpha}{1 - 2\alpha} = 3e^2, -3e^2$$

$$\frac{1 + 2\alpha}{1 - 2\alpha} = 3e^2 \Rightarrow \alpha = \frac{3e^2 - 1}{2(3e^2 + 1)}$$

$$\text{And } \frac{1 + 2\alpha}{1 - 2\alpha} = -3e^2 \Rightarrow \alpha = \frac{3e^2 + 1}{2(3e^2 - 1)}$$

16. Let A be a 2×2 matrix with real entries such that $A' = \alpha A + I$, where $\alpha \in \mathbb{R} - \{-1, 1\}$. If $\det(A^2 - A) = 4$, then the sum of all possible values of α is equal to

(1) 0 (2) $\frac{3}{2}$

(3) $\frac{5}{2}$ (4) 2

Official Ans. by NTA (3)

Sol. $A^T = \alpha A + I$
 $A = \alpha A^T + I$
 $A = \alpha(\alpha A + I) + I$
 $A = \alpha^2 A + (\alpha + 1)I$
 $A(1 - \alpha^2) = (\alpha + 1)I$

$$A = \frac{I}{1 - \alpha} \quad \dots(1)$$

$$|A| = \frac{1}{(1 - \alpha)^2} \quad \dots(2)$$

$$|A^2 - A| = |A||A - I| \quad \dots(3)$$

$$A - I = \frac{I}{1 - \alpha} - I = \frac{\alpha}{1 - \alpha} I$$

$$|A - I| = \left(\frac{\alpha}{1 - \alpha}\right)^2 \quad \dots(4)$$

Now $|A^2 - A| = 4$

$$|A||A - I| = 4$$

$$\Rightarrow \frac{1}{(1 - \alpha)^2} \frac{\alpha^2}{(1 - \alpha)^2} = 4$$

$$\Rightarrow \frac{\alpha}{(1 - \alpha)^2} = \pm 2$$

$$\Rightarrow 2(1 - \alpha)^2 = \pm \alpha$$

$(C_1) 2(1 - \alpha)^2 = \alpha$ $2\alpha^2 - 5\alpha + 2 = 0 <_{\alpha_2}^{\alpha_1}$ $\alpha_1 + \alpha_2 = \frac{5}{2}$	$(C_2) 2(1 - \alpha)^3 = -\alpha$ $2\alpha^2 - 3\alpha + 2 = 0$ $\alpha \notin \mathbb{R}$
--	--

Sum of value of $\alpha = \frac{5}{2}$

17. Let (α, β, γ) be the image of the point $P(2, 3, 5)$ in the plane $2x + y - 3z = 6$. Then $\alpha + \beta + \gamma$ is equal to

- (1) 10
- (2) 5
- (3) 12
- (4) 9

Official Ans. by NTA (1)

Sol. $\frac{\alpha - 2}{2} = \frac{\beta - 3}{1} = \frac{\gamma - 5}{-3} = -2 \left(\frac{2 \times 2 + 3 - 3 \times 5 - 6}{2^2 + 1^2 + 1 - 3^2} \right) = 2$

$\frac{\alpha - 2}{2} = 2$	$\beta - 3 = 2$	$\gamma - 5 = -6$
$\alpha = 6$	$\beta = 5$	$\gamma = -1$

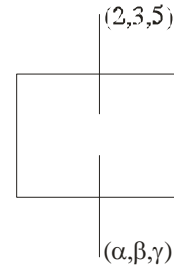

$$\alpha + \beta + \gamma = 10$$

18. Let \vec{a} be a non-zero vector parallel to the line of intersection of the two planes described by $\hat{i} + \hat{j}, \hat{i} + \hat{k}$ and $\hat{i} - \hat{j}, \hat{j} - \hat{k}$. If θ is the angle between the vector \vec{a} and the vector $\vec{b} = 2\hat{i} - 2\hat{j} + \hat{k}$ and $\vec{a} \cdot \vec{b} = 6$ then the ordered pair $(\theta, |\vec{a} \times \vec{b}|)$ is equal to

- (1) $\left(\frac{\pi}{4}, 3\sqrt{6}\right)$
- (2) $\left(\frac{\pi}{3}, 3\sqrt{6}\right)$
- (3) $\left(\frac{\pi}{3}, 6\right)$
- (4) $\left(\frac{\pi}{4}, 6\right)$

Official Ans. by NTA (4)

Sol. n_1 and n_2 are normal vector to the plane $\hat{i} + \hat{j}, \hat{i} + \hat{k}$ and $\hat{i} - \hat{j}, \hat{j} - \hat{k}$ respectively

$$\vec{n}_1 = \begin{vmatrix} \hat{i} & \hat{j} & \hat{k} \\ 1 & 1 & 0 \\ 1 & 0 & 1 \end{vmatrix} = \hat{i} - \hat{j} - \hat{k}$$

$$\vec{n}_2 = \begin{vmatrix} \hat{i} & \hat{j} & \hat{k} \\ 1 & -1 & 0 \\ 1 & 0 & -1 \end{vmatrix} = \hat{i} + \hat{j} + \hat{k}$$

$$\vec{a} = \lambda |\vec{n}_1 \times \vec{n}_2|$$

$$= \lambda \begin{vmatrix} \hat{i} & \hat{j} & \hat{k} \\ 1 & -1 & -1 \\ 1 & 1 & 1 \end{vmatrix} = \lambda(-2\hat{j} + 2\hat{k})$$

$$\vec{a} \cdot \vec{b} = \lambda|0+4+2| = 6$$

$$\Rightarrow \lambda = 1$$

$$\vec{a} = -2\hat{j} + 2\hat{k}$$

$$\cos \theta = \frac{\vec{a} \cdot \vec{b}}{|\vec{a}||\vec{b}|}$$

$$\cos \theta = \frac{6}{2\sqrt{2} \times 3} = \frac{1}{\sqrt{2}}$$

$$\theta = \frac{\pi}{4}$$

$$\text{Now } |\vec{a} \cdot \vec{b}|^2 + |\vec{a} \times \vec{b}|^2 = |\vec{a}|^2 |\vec{b}|^2$$

$$36 + |\vec{a} \times \vec{b}|^2 = 8 \times 9 = 72$$

$$|\vec{a} \times \vec{b}|^2 = 36$$

$$|\vec{a} \times \vec{b}| = 6$$

19. The number of elements in the set $S = \{\theta \in [0, 2\pi] : 3\cos^4 \theta - 5\cos^2 \theta - 2\sin^2 \theta + 2 = 0\}$ is

(1) 10

(2) 8

(3) 9

(4) 12

Official Ans. by NTA (3)

Sol. $3\cos^4 \theta - 5\cos^2 \theta - 2\sin^2 \theta + 2 = 0$
 $\Rightarrow 3\cos^4 \theta - 3\cos^2 \theta - 2\cos^2 \theta - 2\sin^2 \theta + 2 = 0$
 $\Rightarrow 3\cos^4 \theta - 3\cos^2 \theta + 2\sin^2 \theta - 2\sin^2 \theta = 0$
 $\Rightarrow 3\cos^2 \theta (\cos^2 \theta - 1) + 2\sin^2 \theta (\sin^2 \theta - 1) = 0$
 $\Rightarrow -3\cos^2 \theta \sin^2 \theta + 2\sin^2 \theta (1 + \sin^2 \theta) \cos^2 \theta - 1$
 $\Rightarrow \sin^2 \theta \cos^2 \theta (2 + 2\sin^2 \theta - 3) = 0$
 $\Rightarrow \sin^2 \theta \cos^2 \theta (2\sin^2 \theta - 1) = 0$

(C1) $\sin^2 \theta = 0 \rightarrow 3$ solution ; $\theta = \{0, \pi, 2\pi\}$

(C2) $\cos^2 \theta = 0 \rightarrow 2$ solution ; $\theta = \left\{ \frac{\pi}{2}, \frac{3\pi}{2} \right\}$

(C3) $\sin^2 \theta = \frac{1}{2} \rightarrow 4$ solution ; $\theta = \left\{ \frac{\pi}{4}, \frac{3\pi}{4}, \frac{5\pi}{4}, \frac{7\pi}{4} \right\}$

No. of solution = 9

20. Let x_1, x_2, \dots, x_{100} be in an arithmetic progression, with $x_1 = 2$ and their mean equal to 200. If $y_i = i(x_i - i), 1 \leq i \leq 100$, then the mean of y_1, y_2, \dots, y_{100} is .

(1) 10101.50

(2) 10051.50

(3) 10049.50

(4) 10100

Official Ans. by NTA (3)

Sol. Mean = 200

$$\Rightarrow \frac{100}{2}(2 \times 2 + 99d) = 200$$

$$\Rightarrow 4 + 99d = 400$$

$$\Rightarrow d = 4$$

$$y_i = i(x_i - i)$$

$$= i(2 + (i-1)4 - i) = 3i^2 - 2i$$

$$\text{Mean} = \frac{\sum y_i}{100}$$

$$= \frac{1}{100} \sum_{i=1}^{100} 3i^2 - 2i$$

$$= \frac{1}{100} \left\{ \frac{3 \times 100 \times 101 \times 201}{6} - \frac{2 \times 100 \times 101}{2} \right\}$$

$$= 101 \left\{ \frac{201}{2} - 1 \right\} = 101 \times 99.5$$

$$= 10049.50$$

SECTION-B

21. The mean of the coefficients of x, x^2, \dots, x^7 in the binomial expansion of $(2+x)^9$ is _____.

Official Ans. by NTA (2736)

Sol. Coefficient of $x = {}^9C_1 \cdot 2^8$
 Of $x^2 = {}^9C_2 \cdot 2^7$
 Of $x^7 = {}^9C_7 \cdot 2^2$
 Mean = $\frac{{}^9C_1 \cdot 2^8 + {}^9C_2 \cdot 2^7 + \dots + {}^9C_7 \cdot 2^2}{7}$
 $= \frac{(1+2)^9 - {}^9C_0 \cdot 2^9 - {}^9C_8 \cdot 2^1 - {}^9C_9}{7}$
 $= \frac{3^9 - 2^9 - 18 - 1}{7}$
 $= \frac{19152}{7} = 2736$

22. Let $S = 109 + \frac{108}{5} + \frac{107}{5^2} + \dots + \frac{2}{5^{107}} + \frac{1}{5^{108}}$. Then the value of $(16S - (25)^{-54})$ is equal to _____.

Official Ans. by NTA (2175)

Sol. $S = 109 + \frac{108}{5} + \frac{107}{5^2} + \dots + \frac{1}{5^{108}}$
 $\frac{S}{5} = \frac{109}{5} + \frac{108}{5^2} + \dots + \frac{2}{5^{108}} + \frac{1}{5^{109}}$
 $\frac{4S}{5} = 109 - \frac{1}{5} - \frac{1}{5^2} + \dots - \frac{1}{5^{108}} - \frac{1}{5^{109}}$
 $= 109 - \left(\frac{1 \left(1 - \frac{1}{5^{109}} \right)}{5 \left(1 - \frac{1}{5} \right)} \right)$
 $= 109 - \frac{1}{4} \left(1 - \frac{1}{5^{109}} \right)$
 $= 109 - \frac{1}{4} + \frac{1}{4} \times \frac{1}{5^{109}}$
 $s = \frac{5}{4} \left(109 - \frac{1}{4} + \frac{1}{4 \cdot 5^{109}} \right)$
 $16S = 20 \times 109 - 5 + \frac{1}{5^{108}}$
 $16S - (25)^{-54} = 2180 - 5 = 2175$

23. For $m, n > 0$, let $\alpha(m, n) = \int_0^2 t^m (1+3t)^n dt$. If $11\alpha(10, 6) + 18\alpha(11, 5) = p(14)^6$, then p is equal to _____.

Official Ans. by NTA (32)

Sol. $\alpha(m, n) = \int_0^2 t^m (1+3t)^n dt$
 If $11\alpha(10, 6) + 18\alpha(11, 5) = p(14)^6$ then P
 $= 11 \int_0^2 \frac{t^{10}}{II} \frac{(1+3t)^6}{I} + 10 \int_0^2 t^{11} (1+3t)^5 dt$
 $= 11 \left[(1+3t)^6 \cdot \frac{t^{11}}{11} - \int 6(1+3t)^5 \cdot 3 \frac{t^{11}}{11} \right]_0^2 + 18 \int_0^2 t^{11} (1+3t)^5 dt$
 $= \left(t^{11} (1+3t)^6 \right)_0^2$
 $= 2^{11} (7)^6$
 $= 2^5 (14)^6$
 $= 32(14)^6$

24. In an examination, 5 students have been allotted their seats as per their roll numbers. The number of ways, in which none of the students sits on the allotted seat, is _____.

Official Ans. by NTA (44)

Sol. Derangement of 5 students
 $D_5 = 5! \left(1 - \frac{1}{1!} + \frac{1}{2!} - \frac{1}{3!} + \frac{1}{4!} - \frac{1}{5!} \right)$
 $= 120 \left(\frac{1}{2} - \frac{1}{6} + \frac{1}{24} - \frac{1}{120} \right)$
 $= 60 - 20 + 5 - 1$
 $= 40 + 4$
 $= 44$

25. Let a line l pass through the origin and be perpendicular to the lines

$$l_1 : \vec{r} = (\hat{i} - 11\hat{j} - 7\hat{k}) + \lambda (\hat{i} + 2\hat{j} + 3\hat{k}), \lambda \in \mathbb{R}$$

$$\text{and } l_2 : \vec{r} = (-\hat{i} + \hat{k}) + \mu (2\hat{i} + 2\hat{j} + \hat{k}), \mu \in \mathbb{R}.$$

If P is the point of intersection of l and l_1 , and Q(α, β, γ) is the foot of perpendicular from P on l_2 , then $9(\alpha + \beta + \gamma)$ is equal to _____.

Official Ans. by NTA (5)

Sol. Let $l = (0\hat{i} + 0\hat{j} + 0\hat{k}) + \gamma (\hat{i} + 2\hat{j} + 3\hat{k})$

$$= \gamma (\hat{i} + 2\hat{j} + 3\hat{k})$$

$$\hat{i} + 2\hat{j} + 3\hat{k} = \begin{vmatrix} \hat{i} & \hat{j} & \hat{k} \\ 1 & 2 & 3 \\ 2 & 2 & 1 \end{vmatrix}$$

$$= \hat{i}(2-6) - \hat{j}(1-6) + \hat{k}(2-4)$$

$$= -4\hat{i} - 5\hat{j} - 2\hat{k}$$

$$l = \gamma (-4\hat{i} + 5\hat{j} - 2\hat{k})$$

P is intersection of l and l_1

$$-4\gamma = 1 + \lambda, 5\gamma = -11 + 2\lambda, -2\gamma = -7 + 3\lambda$$

By solving there equation $\gamma = -1, P(4, -5, 2)$

Let Q($-1 + 2\mu, 2\mu, 1 + \mu$)

$$\overline{PQ} \cdot (2\hat{i} + 2\hat{j} + \hat{k}) = 0$$

$$-2 + 4\mu + 4\mu + 1 + \mu = 0$$

$$9\mu = 1$$

$$\mu = \frac{1}{9}$$

$$Q\left(\frac{-7}{9}, \frac{2}{9}, \frac{10}{9}\right)$$

$$9(\alpha + \beta + \gamma) = 9\left(\frac{-7}{9} + \frac{2}{9} + \frac{10}{9}\right) = 5$$

26. The number of integral terms in the expansion of

$$\left(3^{\frac{1}{2}} + 5^{\frac{1}{4}}\right)^{680} \text{ is equal to}$$

Official Ans. by NTA (171)

Sol. The number of integral term in the expression of

$$\left(3^{\frac{1}{2}} + 5^{\frac{1}{4}}\right)^{680} \text{ is equal to}$$

$$\begin{aligned} \text{General term} &= {}^{680}C_r \left(3^{\frac{1}{2}}\right)^{680-r} \left(5^{\frac{1}{4}}\right)^r \\ &= {}^{680}C_r 3^{\frac{680-r}{2}} 5^{\frac{r}{4}} \end{aligned}$$

Value's of r, where $\frac{r}{4}$ goes to integer

$$r = 0, 4, 8, 12, \dots, 680$$

All value of r are accepted for $\frac{680-r}{2}$ as well so

No of integral terms = 171.

27. The number of ordered triplets of the truth values of p, q and r such that the truth value of the statement $(p \vee q) \wedge (p \vee r) \Rightarrow (q \vee r)$ is True, is equal to _____.

Official Ans. by NTA (7)

Sol.

p	q	r	Pvq	Pvr	(pvq) ^ (pvr)	qvr	(pvq) ^ (pvr) → qvr
T	T	T	T	T	T	T	T
T	T	F	T	T	T	T	T
T	F	T	T	T	T	T	T
T	F	F	T	T	T	F	F
F	T	T	T	T	T	T	T
F	T	F	T	F	F	T	T
F	F	T	F	T	F	T	T
F	F	F	F	F	F	F	T

Hence total no of ordered triplets are 7

28. Let $H_n = \frac{x^2}{1+n} - \frac{y^2}{3+n} = 1$, $n \in \mathbb{N}$. Let k be the smallest even value of n such that the eccentricity of H_k is a rational number. If l is length of the latus rectum of H_k , then $21l$ is equal to _____

Official Ans. by NTA (306)

Sol. $H_n \Rightarrow \frac{x^2}{1+n} - \frac{y^2}{3+n} = 1$
 $e = \sqrt{1 + \frac{b^2}{a^2}} = \sqrt{1 + \frac{3+n}{1+n}} = \sqrt{\frac{2n+4}{n+1}}$
 $e = \sqrt{\frac{2n+4}{n+1}}$
 $n = 48$ (smallest even value for which $e \in \mathbb{Q}$)

$$\boxed{e = \frac{10}{7}}$$

$$a^2 = n+1 \quad b^2 = n+3$$

$$= 49 \quad , \quad = 51$$

$$l = \text{length of LR} = \frac{2b^2}{a}$$

$$L = 2 \cdot \frac{51}{7}$$

$$l = \frac{102}{7}$$

$$\boxed{21l = 306}$$

29. If a and b are the roots of equation $x^2 - 7x - 1 = 0$, then the value of $\frac{a^{21} + b^{21} + a^{17} + b^{17}}{a^{19} + b^{19}}$ is equal to _____

Official Ans. by NTA (51)

Sol. $x^2 - 7x - 1 = 0 \quad \begin{matrix} a \\ b \end{matrix}$
 By newton's theorem
 $S_{n+2} - 7S_{n+1} - S_n = 0$
 $S_{21} - 7S_{20} - S_{19} = 0$
 $S_{20} - 7S_{19} - S_{18} = 0$
 $S_{19} - 7S_{18} - S_{17} = 0$
 $\frac{S_{21} + S_{17}}{S_{19}} = \frac{S_{21} + (S_{19} - 7S_{18})}{S_{19}}$
 $= \frac{S_{21} + S_{19} - 7(S_{20} - 7S_{19})}{S_{19}}$
 $= \frac{50S_{19} + (S_{21} - 7S_{20})}{S_{19}}$
 $= 51 \cdot \frac{S_{19}}{S_{19}} = \boxed{51}$

30. Let $A = \begin{bmatrix} 0 & 1 & 2 \\ a & 0 & 3 \\ 1 & c & 0 \end{bmatrix}$, where $a, c \in \mathbb{R}$. If $A^3 = A$

and the positive value of a belongs to the interval $(n-1, n]$, where $n \in \mathbb{N}$, then n is equal to _____

Official Ans. by NTA (2)

Sol. $A = \begin{bmatrix} 0 & 1 & 2 \\ a & 0 & 3 \\ 1 & c & 0 \end{bmatrix}$

$$A^3 = A$$

$$A^2 = \begin{bmatrix} 0 & 1 & 2 \\ a & 0 & 3 \\ 1 & c & 0 \end{bmatrix} \begin{bmatrix} 0 & 1 & 2 \\ a & 0 & 3 \\ 1 & c & 0 \end{bmatrix}$$

$$A^2 = \begin{bmatrix} a+2 & 2c & 3 \\ 3 & a+3c & 2a \\ ac & 1 & 2+3c \end{bmatrix}$$

$$A^3 = \begin{bmatrix} a+2 & 2c & 3 \\ 3 & a+3c & 2a \\ ac & a & 2+3c \end{bmatrix} \begin{bmatrix} 0 & 1 & 2 \\ a & 0 & 3 \\ 1 & c & 0 \end{bmatrix}$$

$$A^3 = \begin{bmatrix} 2ac+3 & a+2+3c & 2a+4+6c \\ a(a+3c)+2a & 3+2ac & 6+3a+9c \\ a+2+3c & ac+c(2+3c) & 2ac+3 \end{bmatrix}$$

Given $A^3 = A$

$$2ac+3=0 \dots(1) \quad \text{and} \quad a+2+3c=1$$

$$a+1+3c=0$$

$$a+1-\frac{9}{2a}=0$$

$$2a^2+2a-9=0$$

$$f(1) < 0, f(2) > 0$$

$$a \in (1, 2]$$

$$\boxed{n=2}$$

PHYSICS

TEST PAPER WITH SOLUTION

SECTION-A

31. The electric field in an electromagnetic wave is given as $\vec{E} = 20 \sin \omega \left(t - \frac{x}{c} \right) \hat{j} \text{NC}^{-1}$

Where ω and c are angular frequency and velocity of electromagnetic wave respectively. The energy contained in a volume of $5 \times 10^{-4} \text{m}^3$ will be
(Given $\epsilon_0 = 8.85 \times 10^{-12} \text{C}^2 / \text{Nm}^2$)

- (1) $28.5 \times 10^{-13} \text{J}$ (2) $17.7 \times 10^{-13} \text{J}$
(3) $8.85 \times 10^{-13} \text{J}$ (4) $88.5 \times 10^{-13} \text{J}$

Official Ans. by NTA (3)

Sol. $\vec{E} = 20 \sin \omega \left(t - \frac{x}{c} \right) \hat{j} \text{N} / \text{C}$

Average energy density of an em wave = $\frac{1}{2} \epsilon_0 E_0^2$

Energy stored = $\left(\frac{1}{2} \epsilon_0 E_0^2 \right) (\text{volume})$

$$= \frac{1}{2} \times 8.85 \times 10^{-12} \times (20)^2 \times (5 \times 10^{-4}) \text{J}$$

$$= 8.85 \times 10^{-13} \text{J}$$

32. From the v - t graph shown. the ratio of distance to displacement in 25 s of motion

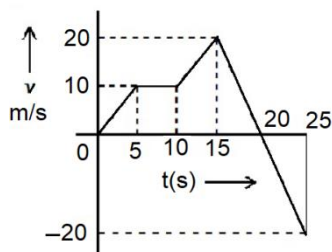

- (1) $\frac{3}{5}$ (2) $\frac{1}{2}$
(3) $\frac{5}{3}$ (4) 1

Official Ans. by NTA (3)

Sol. Area under the graph from $t = 0$ to $t = 20$ sec = 200 m
Area under the graph from $t = 20$ to $t = 25$ sec = 50 m
So distance covered = $(200 + 50) \text{m} = 250 \text{m}$
Displacement = $(200 - 50) \text{m} = 150 \text{m}$

$$\frac{250}{150} = \frac{5}{3}$$

33. The radii of two planets 'A' and 'B' are 'R' and '4R' and their densities are ρ and $\rho/3$ respectively. The ratio of acceleration due to gravity at their surfaces ($g_A : g_B$) will be :

- (1) 1 : 16 (2) 3 : 16
(3) 3 : 4 (4) 4 : 3

Official Ans. by NTA (3)

Sol. $g = \frac{GM}{R^2} = \frac{G}{R^2} \times \rho \times \frac{4\pi}{3} R^3 = \left(\frac{4\pi}{3} G \right) \rho R$

$$\frac{g_A}{g_B} = \frac{R \times \rho}{4R \times \frac{\rho}{3}} = \frac{3}{4}$$

34. A coin placed on a rotating table just slips when it is placed at a distance of 1 cm from the center. If the angular velocity of the table is halved, it will just slip when placed at a distance of _____ from the centre:

- (1) 2 cm
(2) 1 cm
(3) 8 cm
(4) 4 cm

Official Ans. by NTA (4)

Sol. $f_{s \max} = \mu mg = m \omega^2 R \Rightarrow R = \frac{\mu g}{\omega^2}$

So if ω becomes $\frac{\omega}{2}$, R will become 4R.

So distance from the center will be 4 cm.

35. The logic performed by the circuit shown in figure is equivalent to :

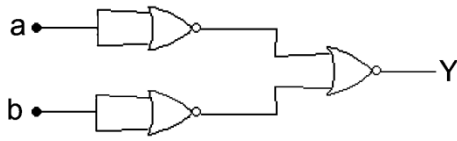

- (1) AND (2) NAND
(3) OR (4) NOR

Official Ans. by NTA (1)

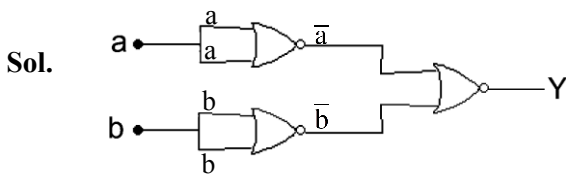

$$Y = \overline{\overline{a} + \overline{b}} = a \cdot b$$

The truth table for the given circuit will be

a	b	output
0	0	0
0	1	0
1	0	0
1	1	1

Hence it will be equivalent to AND gate.

36. A parallel plate capacitor of capacitance 2 F is charged to a potential V. The energy stored in the capacitor is E_1 . The capacitor is now connected to another uncharged identical capacitor in parallel combination. The energy stored in the combination is E_2 . The ratio E_2/E_1 is :

- (1) 2 : 1 (2) 1 : 2
(3) 1 : 4 (4) 2 : 3

Official Ans. by NTA (2)

Sol. Initially

$$Q_1 = CV = (2) V$$

$$E_1 = \frac{1}{2} CV^2 = \frac{1}{2} (2)V^2 = V^2$$

Finally

$$\text{Charge on each capacitor, } Q_2 = \frac{Q_1}{2} = \frac{2V}{2} = V$$

$$E_2 = 2 \left(\frac{1}{2} \frac{Q_2^2}{C} \right) = \frac{V^2}{2} \quad \therefore \frac{E_2}{E_1} = \frac{1}{2}$$

37. Two identical heater filaments are connected first in parallel and then in series. At the same applied voltage, the ratio of heat produced in same time for parallel to series will be:

- (1) 4 : 1 (2) 2 : 1 (3) 1 : 2 (4) 1 : 4

Official Ans. by NTA (1)

Sol. Parallel combination

$$H_p = \left[\frac{V^2}{\left(\frac{R}{2}\right)} \right] t = \frac{2V^2 t}{R}$$

Series combination

$$H_s = \left(\frac{V^2}{2R} \right) t \quad \therefore \frac{H_p}{H_s} = 4$$

38. A transmitting antenna is kept on the surface of the earth. The minimum height of receiving antenna required to receive the signal in line of sight at 4 km distance from it is $x \times 10^{-2}$ m. The value of x is (Let. radius of earth $R = 6400$ km)

- (1) 125 (2) 12.5 (3) 1.25 (4) 1250

Official Ans. by NTA (1)

Sol. $d_r = \sqrt{2h_r R} \quad \therefore h_r = \frac{d_r^2}{2R}$

$$= \frac{(4\text{km})^2}{2(6400\text{ km})} = \left(\frac{1}{800} \right) \text{km} = 1.25\text{ m}$$

39. As per the given graph choose the correct representation for curve A and curve B.

{Where X_C = reactance of pure capacitive circuit connected with A.C. source

X_L = reactance of pure inductive circuit connected with A.C. source

R = impedance of pure resistive circuit connected with A.C. source

Z = Impedance of the LCR series circuit}

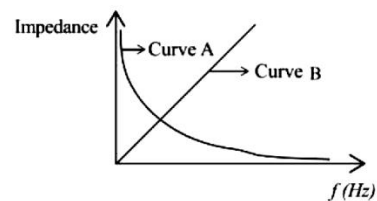

- (1) $A = X_C, B = R$ (2) $A = X_L, B = Z$
(3) $A = X_C, B = X_L$ (4) $A = X_L, B = R$

Official Ans. by NTA (3)

Sol. $X_c = \frac{1}{\omega C} = \frac{1}{(2\pi f)C}$

$\therefore X_c \propto \frac{1}{f}$

\therefore Curve A

$X_L = \omega L = (2\pi f)L$

$\therefore X_L \propto f$

\therefore Curve B

- 40.** 1 kg of water at 100°C is converted into steam at 100°C by boiling at atmospheric pressure. The volume of water changes from $1.00 \times 10^{-3} \text{ m}^3$ as a liquid to 1.671 m^3 as steam. The change in internal energy of the system during the process will be (Given latent heat of vaporisation = 2257 kJ/kg. Atmospheric pressure = $1 \times 10^5 \text{ Pa}$)

(1) + 2090 kJ (2) - 2090 kJ

(3) - 2426 kJ (4) + 2476 kJ

Official Ans. by NTA (1)

Sol. $\Delta Q = \Delta U + \Delta W$

$\therefore \Delta U = \Delta Q - \Delta W$

$= mL_v - P\Delta V$

$= (1\text{Kg})(2257 \times 10^3 \text{ J / kg})$

$- (1 \times 10^5 \text{ Pa})(1.671 \text{ m}^3 - 1 \times 10^{-3} \text{ m}^3)$

$= 2257 \times 10^3 \text{ J} - 167 \times 10^3 \text{ J}$

$= 2090 \text{ KJ}$

- 41.** The critical angle for a denser-rarer interface is 45°. The speed of light in rarer medium is $3 \times 10^8 \text{ ms}$. The speed of light in the denser medium is:

(1) $5 \times 10^7 \text{ m/s}$ (2) $2.12 \times 10^8 \text{ m/s}$

(3) $3.12 \times 10^7 \text{ m/s}$ (4) $\sqrt{2} \times 10^8 \text{ m/s}$

Official Ans. by NTA (2)

Sol. $i_c = \text{Critical angle}$

$\frac{v}{C} = \frac{1}{\mu} = \sin i_c = \sin 45^\circ = \frac{1}{\sqrt{2}}$

$\Rightarrow v = \frac{C}{\sqrt{2}} = \frac{3 \times 10^8}{\sqrt{2}} \text{ m/s} = 2.12 \times 10^8 \text{ m/s}$

- 42.** A metallic surface is illuminated with radiation of wavelength λ , the stopping potential is V_0 . If the same surface is illuminated with radiation of wavelength 2λ , the stopping potential becomes $\frac{V_0}{4}$. The threshold wavelength for this metallic surface will be -

(1) $\frac{\lambda}{4}$ (2) 4λ

(3) $\frac{3}{2}\lambda$ (4) 3λ

Official Ans. by NTA (4)

- Sol.** From the equation of photoelectric effect

$eV_0 = \frac{hc}{\lambda} - \phi_0 = \frac{hc}{\lambda} - \frac{hc}{\lambda_0}$

$\& \frac{eV_0}{4} = \frac{hc}{2\lambda} = \frac{hc}{\lambda_0}$

$\Rightarrow \frac{1}{4} \left(\frac{hc}{\lambda} - \frac{hc}{\lambda_0} \right) = \frac{hc}{2\lambda} - \frac{hc}{\lambda_0}$

$\frac{1}{\lambda_0} - \frac{1}{4\lambda_0} = \frac{1}{2\lambda} - \frac{1}{4\lambda}$

$\frac{3}{4\lambda_0} = \frac{1}{4\lambda}$

$\Rightarrow \lambda_0 = 3\lambda$

- 43.** The free space inside a current carrying toroid is filled with a material of susceptibility 2×10^{-2} . The percentage increase in the value of magnetic field inside the toroid will be

(1) 2% (2) 0.2%

(3) 0.1% (4) 1%

Official Ans. by NTA (1)

Sol. As $X_m = 2 \times 10^{-2}$

$\mu_r = 1 + X_m = 1.02$

$\Rightarrow B = \mu_r B_0 = 1.02 B_0$

So percentage increase in magnetic field

$= \frac{B - B_0}{B_0} \times 100\% = 2\%$

53. The equation of wave is given by

$$Y = 10^{-2} \sin 2\pi \left(160t - 0.5x + \frac{\pi}{4} \right)$$

Where x and Y are in m and t in s. The speed of the wave is ____ km h^{-1}

Official Ans. by NTA (1152)

Sol.
$$V = \frac{\omega}{k} = \frac{2\pi \times 60}{2\pi \times 0.5} = \frac{160}{0.5} \text{ m/s}$$

$$= \frac{160}{0.5} \times \frac{18}{5} \text{ km/h}$$

$$= 1152 \text{ km}$$

54. A force $\vec{F} = (2 + 3x)\hat{i}$ acts on a particle in the x direction where F is in newton and x is in meter. The work done by this force during a displacement from $x = 0$ to $x = 4$ m, is ____ J.

Official Ans. by NTA (32)

Sol.
$$W = \int_0^4 (2 + 3x) dx$$

$$= \left[2x + \frac{3x^2}{2} \right]_0^4$$

$$= 8 + 3 \times 8$$

$$= 32 \text{ J}$$

55. As shown in the figure. a configuration of two equal point charges ($q_0 = +2\mu \text{ C}$) is placed on an inclined plane. Mass of each point charge is 20 g. Assume that there is no friction between charge and plane. For the system of two point charges to be in equilibrium (at rest) the height $h = x \times 10^{-3}$ m. The value of x is ____.

(Take $\frac{1}{4\pi\epsilon_0} = 9 \times 10^9 \text{ N m}^2 \text{ C}^{-2}$, $g = 10 \text{ ms}^{-1}$)

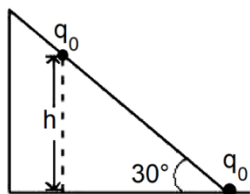

Official Ans. by NTA (300)

Sol. For equilibrium along the plane

$$mg \sin \theta = \frac{1}{4\pi\epsilon_0} \times \frac{q_0^2}{(h \operatorname{cosec} 30^\circ)^2}$$

$$\therefore h^2 = \frac{1}{4\pi\epsilon_0} \times \frac{q_0^2}{mg \operatorname{cosec} 30^\circ}$$

$$= 9 \times 10^9 \times \frac{(2 \times 10^{-6})^2}{0.02 \times 10 \times 2}$$

$$\therefore h = 3 \times 10^4 \times \frac{2 \times 10^{-6}}{0.2}$$

$$= 0.3 \text{ m}$$

$$= 300 \text{ mm}$$

56. A solid sphere of mass 500 g and radius 5 cm is rotated about one of its diameter with angular speed of 10 rad s^{-1} . If the moment of inertia of the sphere about its tangent is $x \times 10^{-2}$ times its angular momentum about the diameter. Then the value of x will be ____.

Official Ans. by NTA (35)

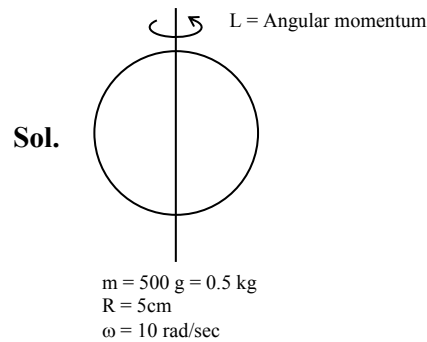

moment of inertia about tangent = I_T

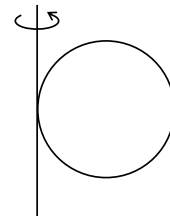

$$I_t = x \times 10^{-2} L$$

$$\frac{7}{5} mR^2 = x \times 10^{-2} \frac{2}{5} mR^2 \omega$$

$$\frac{7}{2\omega} = x \times 10^{-2} = \frac{7}{2 \times 10}$$

57. The length of wire becomes l_1 and l_2 when 100N and 120 N tensions are applied respectively. If $10 l_2 = 11 l_1$, the natural length of wire will be $\frac{1}{x} l_1$.

Here the value of x is _____.

Official Ans. by NTA (2)

Sol. Let the original length be ' l_0 '

When $T_1 = 100$ N, Extension = $l_1 - l_0$

When $T_2 = 120$ N, Extension = $l_2 - l_0$

Then $100 = K(l_1 - l_0)$... (1)

And $120 = K(l_2 - l_0)$... (2)

$$\frac{1}{2} \Rightarrow \frac{5}{6} = \frac{l_1 - l_0}{l_2 - l_0}$$

$$5l_2 - 5l_0 = 6l_1 - 6l_0$$

$$l_0 = 6l_1 - 5l_2$$

$$l_0 = 6l_1 - 5\left(\frac{11l_1}{10}\right)$$

$$l_0 = 6l_1 - \frac{11l_1}{2}$$

$$l_0 = \frac{l_1}{2}$$

$$\therefore x = 2$$

58. The magnetic field B crossing normally a square metallic plate of area 4 m^2 is changing with time as shown in figure. The magnitude of induced emf in the plate during $t = 2\text{s}$ to $t = 4\text{s}$, is _____ mV

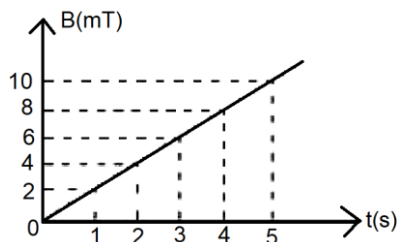

Official Ans. by NTA (8)

Sol. $m = \tan \theta = \frac{10}{5} = 2$

$$B = mt$$

$$B = 2t$$

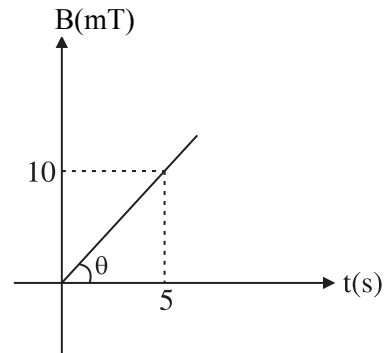

$$\varepsilon = \left| \frac{d\phi}{dt} \right| = \frac{d(BA)}{dt} = \frac{AdB}{dt}$$

$$\varepsilon = \frac{4d(2t)}{dt} = 4 \times 2 = 8 \text{ mVolt}$$

59. A projectile fired at 30° to the ground is observed to be at same height at time 3s and 5s after projection, during its flight. The speed of projection of the projectile is _____ ms^{-1}

(Given $g = 10 \text{ m s}^{-2}$)

Official Ans. by NTA (80)

Sol. Time of flight $t_1 + t_2 = 3 + 5 = 8 \text{ sec}$

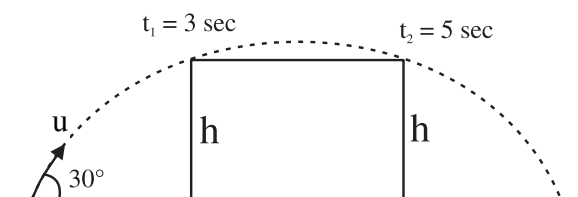

$$T = \frac{2u \sin 30^\circ}{g}$$

$$8 = \frac{2u \sin(30^\circ)}{10}$$

$$u = 80 \text{ m/s}$$

60. In the circuit diagram shown in figure given below, the current flowing through resistance 3Ω is $\frac{x}{3}$ A.

The value of x is ____.

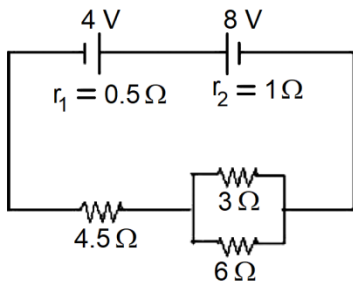

Official Ans. by NTA (1)

Sol.

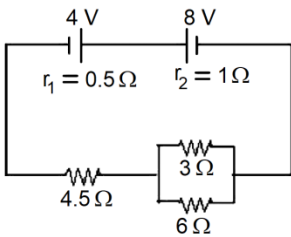

$$E_2 - E_1 = 8 - 4 = 4V$$

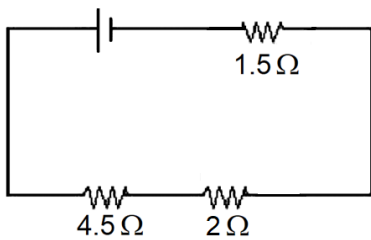

$$\frac{1}{3} + \frac{1}{6} = \frac{1}{2} = \frac{1}{R}$$

$$R = 2\Omega$$

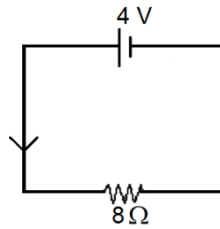

$$I = \frac{4}{8} = 0.5A$$

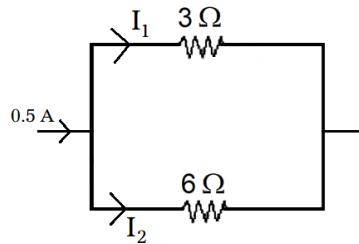

$$I_1 = \left(\frac{6}{3+6} \right) \times 0.5$$

$$I_1 = \frac{2}{3} \times 0.5 = \frac{1}{3} A$$

$$I_1 = \frac{x}{3} = \frac{1}{3} \therefore x = 1$$

CHEMISTRY

TEST PAPER WITH SOLUTION

SECTION-A

61. L-isomer of tetrose X (C₄H₈O₄) gives positive Schiff's test and has two chiral carbons. On acetylation, 'X' yields triacetate. 'X' also undergoes following reactions

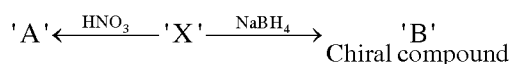

'X' is

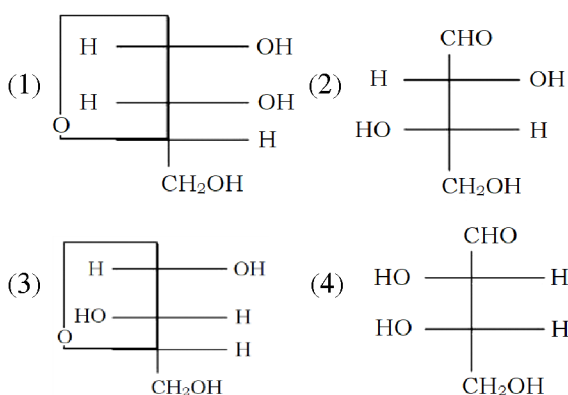

Official Ans. by NTA (2)

Sol.

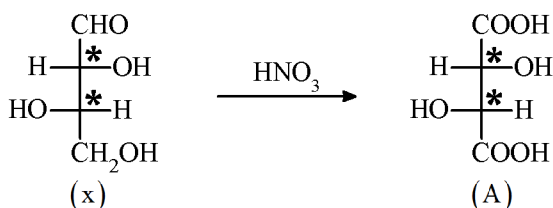

L-tetrose with two chiral centre

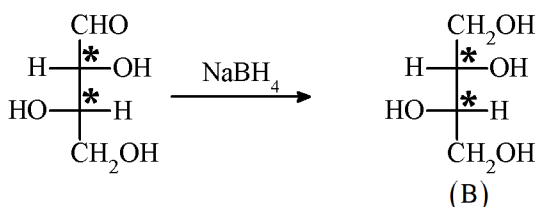

optically active

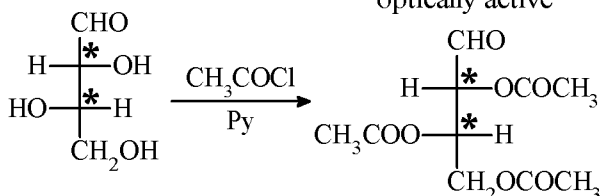

(x) gives positive schiff's test due -CHO group

(x) is L-tetrose.

62. The polymer X – consists of linear molecules and is closely packed. It is prepared in the presence of triethylaluminium and titanium tetrachloride under low pressure. The polymer X is –

- (1) Polyacrylonitrile
- (2) Low density polythene
- (3) Polytetrafluoroethane
- (4) High density polythene

Official Ans. by NTA (4)

Sol. Ethene undergoes addition polymerisation to high density polythene in the presence of catalyst such as AlEt₃ and TiCl₄ (Ziegler – Natta catalyst) at a temperature of 333 K to 343 K and under a pressure of 6–7 atmosphere.

63. When a solution of mixture having two inorganic salts was treated with freshly prepared ferrous sulphate in acidic medium, a dark brown ring was formed whereas on treatment with neutral FeCl₃, it gave deep red colour which disappeared on boiling and a brown red ppt was formed. The mixture contains

- (1) CH₃COO⁻ & NO₃⁻
- (2) C₂O₄²⁻ & NO₃⁻
- (3) SO₃²⁻ & CH₃COO⁻
- (4) SO₃²⁻ & C₂O₄²⁻

Official Ans. by NTA (1)

Sol. CH₃COO⁻ + FeCl₃ → Fe(CH₃COO)₃ or

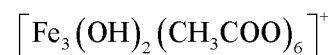

Blood red colour

↓ Δ

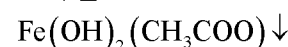

Red-brown precipitate

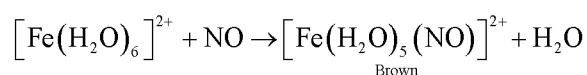
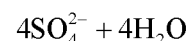
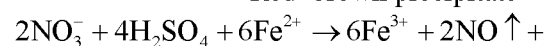

64. Given below are two statements : one is labelled as Assertion A and the other is labelled as Reason R :

Assertion A : In the photoelectric effect, the electrons are ejected from the metal surface as soon as the beam of light of frequency greater than threshold frequency strikes the surface.

Reason R : When the photon of any energy strikes an electron in the atom, transfer of energy from the photon to the electron takes place.

In the light of the above statements, choose the most appropriate answer from the options given below :

- (1) Both A and R are correct but R is NOT the correct explanation of A
- (2) A is correct but R is not correct
- (3) Both A and R are correct and R is the correct explanation of A
- (4) A is not correct but R is correct

Official Ans. by NTA (2)

Sol. There is a characteristic minimum frequency, or "threshold frequency," for each metal below which the photoelectric effect is not seen. The ejected electrons leave with a specific amount of kinetic energy at a frequency $\nu > \nu_0$ with an increase in light frequency of these electron kinetic energies also rise.

65. 25 mL of silver nitrate solution (1 M) is added dropwise to 25 mL of potassium iodide (1.05 M) solution. The ion(s) present in very small quantity in the solution is/are

- (1) NO_3^- only
- (2) K^+ only
- (3) Ag^+ and I^- both
- (4) I^- only

Official Ans. by NTA (3)

Sol. $\text{AgNO}_3 + \text{KI} \rightarrow \text{AgI} \downarrow + \text{KNO}_3$

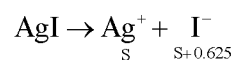

AgI is a insoluble salt so concentration Ag^+ and I^- will be negligible.

66. 'A' and 'B' in the below reactions are :

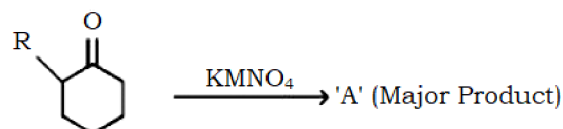

(R = alkyl)

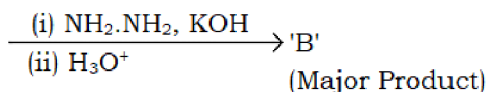

- (1) $\text{R}-\text{CH}(\text{CO}_2\text{H})-\text{CH}_2-\text{CH}_2-\text{CH}_2-\text{CH}_2-\text{CHO} = \text{A}$,
 $\text{B} = \text{R}-\text{CH}(\text{CO}_2\text{H})-\text{CH}_2-\text{CH}_2-\text{CH}_2-\text{CH}_2-\text{CH}_3$
- (2) $\text{R}-\text{C}(=\text{O})-\text{CH}_2-\text{CH}_2-\text{CH}_2-\text{CH}_2-\text{CHO} = \text{A}$,
 $\text{B} = \text{R}-\text{C}(=\text{O})-\text{CH}_2-\text{CH}_2-\text{CH}_2-\text{CH}_2-\text{CH}_3$
- (3) $\text{R}-\text{CH}(\text{CO}_2\text{H})-\text{CH}_2-\text{CH}_2-\text{CH}_2-\text{CH}_2-\text{CO}_2\text{H} = \text{A}$,
 $\text{B} = \text{R}-\text{CH}(\text{C}(\text{O})\text{NHNH}_2)-\text{CH}_2-\text{CH}_2-\text{CH}_2-\text{CH}_2-\text{C}(\text{O})\text{NHNH}_2$
- (4) $\text{R}-\text{C}(=\text{O})-\text{CH}_2-\text{CH}_2-\text{CH}_2-\text{CH}_2-\text{CO}_2\text{H} = \text{A}$,
 $\text{B} = \text{R}-\text{C}(=\text{O})-\text{CH}_2-\text{CH}_2-\text{CH}_2-\text{CH}_2-\text{CO}_2\text{H}$

Official Ans. by NTA (4)

Sol.

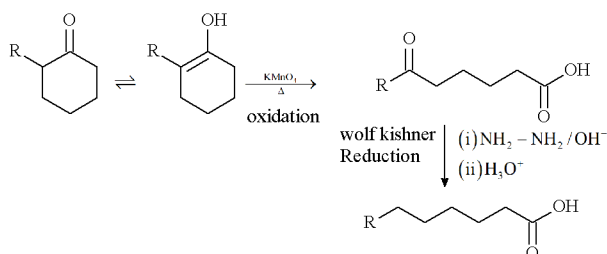

67. The set which does not have ambidentate ligand(s) is

- (1) $\text{C}_2\text{O}_4^{2-}$, ethylene diammine, H_2O
- (2) EDTA^{4-} , NCS^- , $\text{C}_2\text{O}_4^{2-}$
- (3) NO_2^- , $\text{C}_2\text{O}_4^{2-}$, EDTA^{4-}
- (4) $\text{C}_2\text{O}_4^{2-}$, NO_2^- , NCS^-

Official Ans. by NTA (1)

Sol. NO_2^- , NCS^- are ambidentate ligand

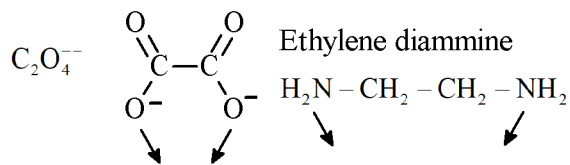

EDTA Ethylene diamine tetra acetate

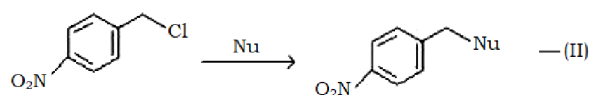
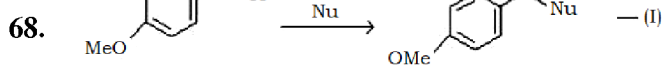
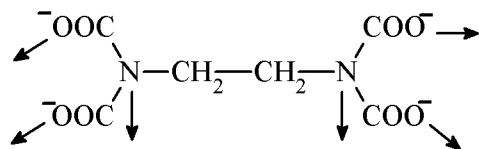

Where Nu = Nucleophile

Find out the correct statement from the options given below for the above 2 reactions.

- (1) Reaction (I) is of 2nd order and reaction (II) is of 1st order
- (2) Reaction (I) and (II) both are of 2nd order
- (3) Reaction (I) is of 1st order and reaction (II) is of 2nd order
- (4) Reactions (I) and (II) both are of 1st order

Official Ans. by NTA (3)

Sol.

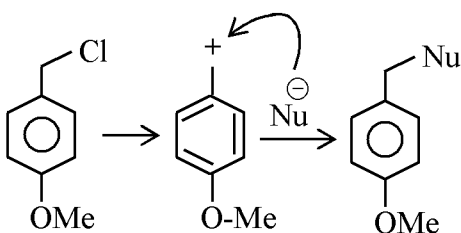

Electron Donating group

S_{N}^1 Mech. : 1st order

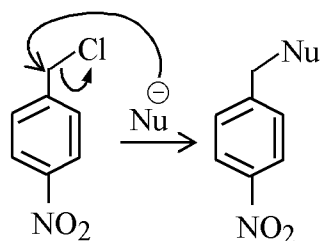

Electron withdrawing group

S_{N}^2 Mech. : 2nd order

69. For elements B, C, N, Li, Be, O and F the correct order of first ionization enthalpy is

- (1) $\text{Li} < \text{Be} < \text{B} < \text{C} < \text{N} < \text{O} < \text{F}$
- (2) $\text{B} > \text{Li} > \text{Be} > \text{C} > \text{N} > \text{O} > \text{F}$
- (3) $\text{Li} < \text{B} < \text{Be} < \text{C} < \text{O} < \text{N} < \text{F}$
- (4) $\text{Li} < \text{Be} < \text{B} < \text{C} < \text{O} < \text{N} < \text{F}$

Official Ans. by NTA (3)

Sol. First I.E.

$\text{F} > \text{N} > \text{O} > \text{C} > \text{Be} > \text{B} > \text{Li}$

Li – 520 kJ/mol

Be – 899 kJ/mol

B – 801 kJ/mol

C – 1086 kJ/mol

N – 1402 kJ/mol

O – 1314 kJ/mol

F – 1681 kJ/mol

70. Match List-I with List-II :

List-I Species	List-II Geometry/Shape
A. H_3O^+	I. Tetrahedral
B. Acetylide anion	II. Linear
C. NH_4^+	III. Pyramidal
D. ClO_2^-	IV. Bent

Choose the correct answer from the options given below :

- (1) A-III, B-II, C-I, D-IV
- (2) A-III, B-I, C-II, D-IV
- (3) A-III, B-IV, C-I, D-II
- (4) A-III, B-IV, C-II, D-I

Official Ans. by NTA (1)

Sol. Molecule/Ion Hybridisation Shape

H_3O^+	sp^3	Pyramidal	
Acetylide	sp	linear	$\text{C} \equiv \text{C}$
NH_4^+	sp^3	tetrahedral	
ClO_2^-	sp^3	Bent	

71. For compound having the formula GaAlCl_4 , the correct option from the following is

- (1) Ga is more electronegative than Al and is present as a cationic part of the salt GaAlCl_4
- (2) Oxidation state of Ga in the salt GaAlCl_4 is +3.
- (3) Cl forms bond with both Al and Ga in GaAlCl_4
- (4) Ga is coordinated with Cl in GaAlCl_4

Official Ans. by NTA (1)

Sol. Gallous tetrachloro aluminate $\text{Ga}^+ \text{AlCl}_4^-$

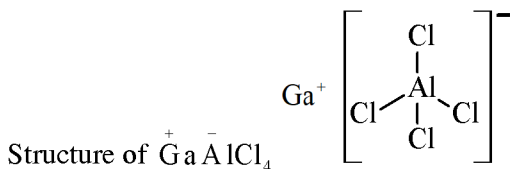
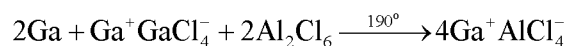

Ga is cationic part of salt GaAlCl_4 .

72. In the extraction process of copper, the product obtained after carrying out the reactions

- (i) $2\text{Cu}_2\text{S} + 3\text{O}_2 \rightarrow 2\text{Cu}_2\text{O} + 2\text{SO}_2$
- (ii) $2\text{Cu}_2\text{O} + \text{Cu}_2\text{S} \rightarrow 6\text{Cu} + \text{SO}_2$ is called

- (1) Blister copper
- (2) Copper scrap
- (3) Reduced copper
- (4) Copper matte

Official Ans. by NTA (1)

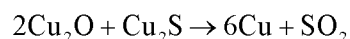
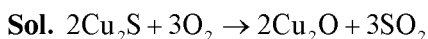

Blister copper

Due to evolution of SO_2 , the solidified copper formed has a blistered look and is referred to as blister copper.

73. Match List-I with List-II :

List-I	List-II
A. K	I. Thermonuclear reactions
B. KCl	II. Fertilizer
C. KOH	III. Sodium potassium pump
D. Li	IV. Absorbent of CO_2

Choose the correct answer from the options given below :

- (1) A-III, B-II, C-IV, D-I
- (2) A-IV, B-I, C-III, D-II
- (3) A-IV, B-III, C-I, D-II
- (4) A-III, B-IV, C-II, D-I

Official Ans. by NTA (1)

Sol. K^+ – Sodium – Potassium Pump

KCl – Fertiliser

KOH – absorber of CO_2

Li – used in thermonuclear reactions

74. Thin layer chromatography of a mixture shows the following observation :

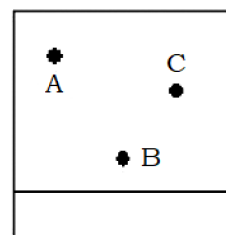

The correct order of elution in the silica gel column chromatography is

- (1) A, C, B
- (2) B, C, A
- (3) C, A, B
- (4) B, A, C

Official Ans. by NTA (1)

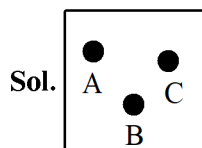

According to the observation, A is more mobile and interacts with the mobile phase more than C, and C is more drawn to the mobile phase than B.

Hence, the correct order of elution in the silica gel column chromatography is – $B < C < A$

75. Which of the following complex has a possibility to exist as meridional isomer?

- (1) $[\text{Co}(\text{NH}_3)_3(\text{NO}_2)_3]$
- (2) $[\text{Co}(\text{en})_3]$
- (3) $[\text{Co}(\text{en})_2\text{Cl}_2]$
- (4) $[\text{Pt}(\text{NH}_3)_2\text{Cl}_2]$

Official Ans. by NTA (1)

Sol. $[\text{MA}_3\text{B}_3]$ type of compound exists as facial and meridional isomer.



76. Given below are two statements :

Statement-I : Methane and steam passed over a heated Ni catalyst produces hydrogen gas.

Statement-II : Sodium nitrite reacts with NH_4Cl to give H_2O , N_2 and NaCl .

In the light of the above statements, choose the most appropriate answer from the options given below :

- (1) Both the statements I and II are correct
- (2) Both the statements I and II are incorrect
- (3) Statement I is incorrect but Statement II is correct
- (4) Statement I is correct but Statement II is incorrect

Official Ans. by NTA (1)

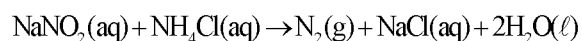
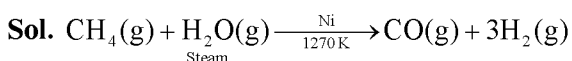

77. Given below are two statements :

Statement I : If BOD is 4 ppm and dissolved oxygen is 8 ppm, then it is a good quality water.

Statement II : If the concentration of zinc and nitrate salts are 5 ppm each, then it can be a good quality water.

In the light of the above statements, choose the most appropriate answer from the options given below :

- (1) Both the statements I and II are incorrect
- (2) Statement I is incorrect but Statement II is correct
- (3) Both the statements I and II are correct
- (4) Statement I is correct but Statement II is incorrect

Official Ans. by NTA (3)

Sol. Clean water would have BOD value of less than 5 ppm.

Maximum limit of Zn in clean water = 5.0 ppm or mg dm^{-3}

Maximum limit of NO_3^- in clean water = 50 ppm or mg dm^{-3}

78. Arrange the following compounds in increasing order of rate of aromatic electrophilic substitution reaction

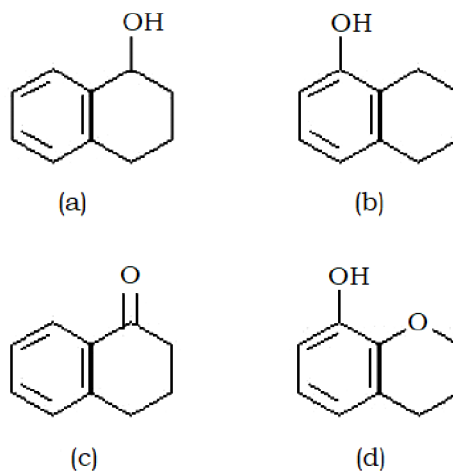

- (1) d, b, c, a
- (2) b, c, a, d
- (3) c, a, b, d
- (4) d, b, a, c

Official Ans. by NTA (3)

Sol. Benzene becomes more reactive towards EAS when any substituent raises the electron density.

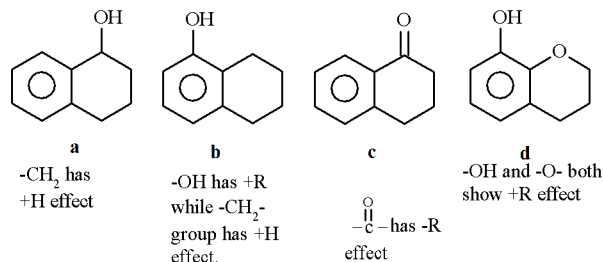

Correct order

$c < a < b < d$

79. The complex that dissolves in water is

- (1) $\text{Fe}_4[\text{Fe}(\text{CN})_6]_3$
- (2) $[\text{Fe}_3(\text{OH})_2(\text{OAc})_6]\text{Cl}$
- (3) $\text{K}_3[\text{Co}(\text{NO}_2)_6]$
- (4) $(\text{NH}_4)_3[\text{As}(\text{Mo}_3\text{O}_{10})_4]$

Official Ans. by NTA (2)

Allen Ans. (2)

Sol. $\text{Fe}_4[\text{Fe}(\text{CN})_6]_3$ Prussian Blue—water insoluble

$\text{K}_3[\text{Co}(\text{NO}_2)_6]$ very poorly water soluble

$(\text{NH}_4)_3[\text{As}(\text{MO}_3\text{O}_{10})_4]$ water insoluble

ammonium arseno molybdate

$[\text{Fe}_3(\text{OH})_2(\text{OAc})_6]\text{Cl}$ is water soluble.

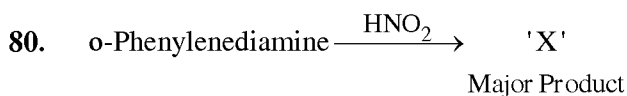

'X' is

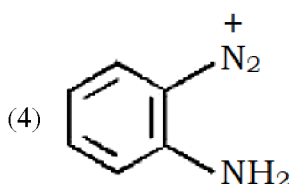
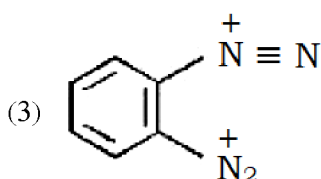
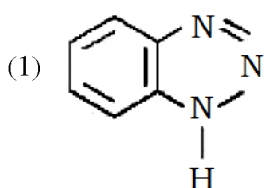

Official Ans. by NTA (1)

Sol. Orthophenyl amine.

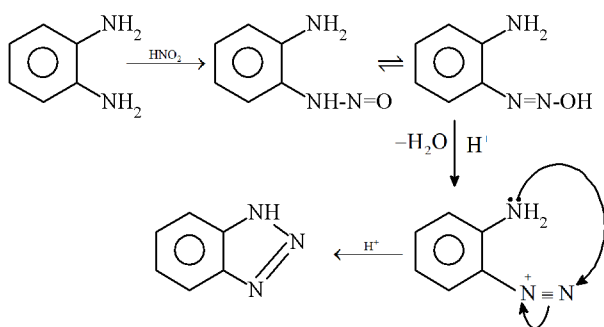

SECTION-B

81. A mixture of 1 mole of H_2O and 1 mole of CO is taken in a 10 litre container and heated to 725 K. At equilibrium 40% of water by mass reacts with carbon monoxide according to the equation :

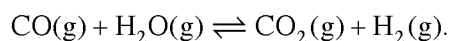

The equilibrium constant $K_C \times 10^2$ for the reaction is _____. (Nearest integer)

Official Ans. by NTA (44)

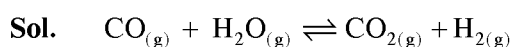

t = 0 1 mol 1 mol 0 0

at equ. 1-x 1-x x x

at equilibrium 40% by mass water reacts with CO

x = 0.4 1 - x = 0.6

$$K_C = \frac{[\text{CO}_2][\text{H}_2]}{[\text{CO}][\text{H}_2\text{O}]} = \frac{0.4 \times 0.4}{0.6 \times 0.6} = 0.44$$

$K_C \times 10^2 = 44$

82. The ratio of spin-only magnetic moment values $\mu_{\text{eff}}[\text{Cr}(\text{CN})_6]^{3-} / \mu_{\text{eff}}[\text{Cr}(\text{H}_2\text{O})_6]^{3+}$ is _____.

Official Ans. by NTA (1)

Sol. Spin magnetic moment of $[\text{Cr}(\text{CN})_6]^{3-} (t_{2g}^3 e_g^0)$

$$\mu_1 = \sqrt{3(3+2)} = \sqrt{15} \text{ BM}$$

Spin magnetic moment of $[\text{Cr}(\text{H}_2\text{O})_6]^{3+} (t_{2g}^3 e_g^0)$

$$\mu_2 = \sqrt{3(3+2)} = \sqrt{15} \text{ BM}$$

$$\frac{\mu_1}{\mu_2} = \frac{\sqrt{15}}{\sqrt{15}} = 1$$

83. An atomic substance A of molar mass 12 g mol^{-1} has a cubic crystal structure with edge length of 300 pm. The no. of atoms present in one unit cell of A is _____. (Nearest integer)

Given the density of A is 3.0 g mL^{-1} and $N_A = 6.02 \times 10^{23} \text{ mol}^{-1}$

Official Ans. by NTA (4)

Sol. $d = 3 \text{ g/cc}$ $M = 12 \text{ g/mol}$

$a = 300 \text{ pm} = 3 \times 10^{-8} \text{ cm}$

$$Z = \frac{d \times N_A \times a^3}{M} = \frac{3 \times 6.02 \times 10^{23} \times (3 \times 10^{-8})^3}{12}$$

$= 4.06 \approx 4$

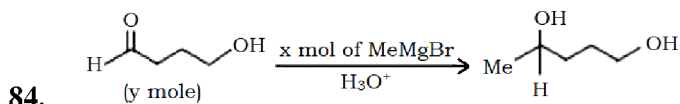

The ratio x/y on completion of the above reaction is _____.

Official Ans. by NTA (2)

Sol.

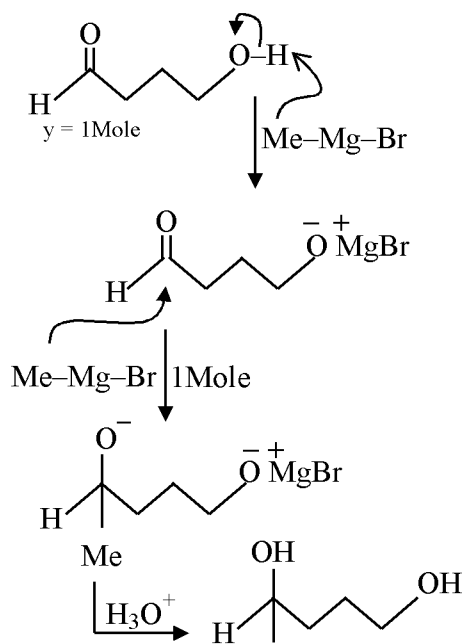

$\therefore x = 2 \text{ mole}$

$$\frac{x}{y} = \frac{2}{1} = 2$$

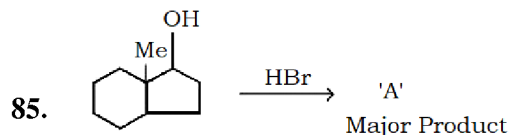

The number of hyperconjugation structures involved to stabilize carbocation formed in the above reaction is _____.

Official Ans. by NTA (7)

Sol.

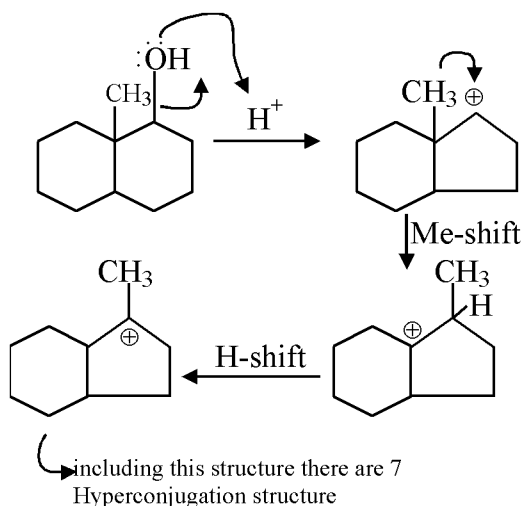

86. Solid fuel used in rocket is a mixture of Fe_2O_3 and Al (in ratio 1 : 2). The heat evolved (kJ) per gram of the mixture is _____ (Nearest integer)

Given : $\Delta H_f^\circ (\text{Al}_2\text{O}_3) = -1700 \text{ kJ mol}^{-1}$

$$\Delta H_f^\circ (\text{Fe}_2\text{O}_3) = -840 \text{ kJ mol}^{-1}$$

Molar mass of Fe, Al and O are 56, 27 and 16 g mol^{-1} respectively.

Official Ans. by NTA (4)

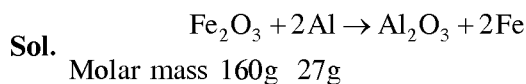

$$\begin{aligned} (\Delta H_f^\circ)_{\text{reaction}} &= [(\Delta H_f^\circ)_{\text{Al}_2\text{O}_3} + 2(\Delta H_f^\circ)_{\text{Fe}}] - \\ &\quad [(\Delta H_f^\circ)_{\text{Fe}_2\text{O}_3} + 2(\Delta H_f^\circ)_{\text{Al}}] \\ &= [-1700 + 0] - [-840 + 0] \\ &= -860 \text{ kJ/mol} \end{aligned}$$

Total mass of mixture = $\text{Fe}_2\text{O}_3 + \text{Al}$ (1 : 2 molar ratio)
 $= 160 + 2 \times 27$
 $= 214 \text{ g/mol}$

Heat evolved per gram = $\frac{860}{214} = 4 \text{ kJ / g}$

87. A solution of sugar is obtained by mixing 200 g of its 25% solution and 500 g of its 40% solution (both by mass). The mass percentage of the resulting sugar solution is _____. (Nearest integer)

Official Ans. by NTA (36)

Sol. Total mass of sugar in mixture of 25% of 200 and 40% of 500 g

$$\text{Sugar solution} = 0.25 \times 200 + 0.40 \times 500$$

$$= 50 + 200 = 250 \text{ g}$$

$$\text{Total mass of solution} = 200 + 500 = 700 \text{ g}$$

$$\text{Mass of sugar in solution} = \frac{250}{700} \times 100 = 35.7\%$$

$$\approx 36\%$$

88. $\text{KClO}_3 + 6\text{FeSO}_4 + 3\text{H}_2\text{SO}_4 \rightarrow$



The above reaction was studied at 300 K by monitoring the concentration of FeSO_4 in which initial concentration was 10 M and after half an hour became 8.8 M. The rate of production of $\text{Fe}_2(\text{SO}_4)_3$ is _____ $\times 10^{-6} \text{ mol L}^{-1} \text{ s}^{-1}$.

(Nearest integer)

Official Ans. by NTA (333)

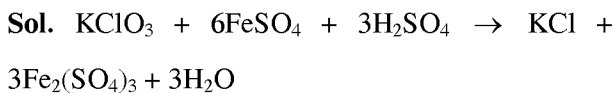

$$\begin{aligned} \text{ROR} &= -\frac{\Delta[\text{KClO}_3]}{\Delta t} = \frac{-1}{6} \frac{\Delta[\text{FeSO}_4]}{\Delta t} \\ &= \frac{+1}{3} \frac{\Delta[\text{Fe}_2(\text{SO}_4)_3]}{\Delta t} \end{aligned}$$

$$\begin{aligned} \frac{\Delta[\text{Fe}_2(\text{SO}_4)_3]}{\Delta t} &= \frac{1}{2} \frac{-\Delta[\text{FeSO}_4]}{\Delta t} \\ &= \frac{1}{2} \frac{(10 - 8.8)}{30 \times 60} \end{aligned}$$

$$= 0.333 \times 10^{-3}$$

$$= 333 \times 10^{-6} \text{ mol litre}^{-1} \text{ sec}^{-1}$$

89. 0.004 M K_2SO_4 solution is isotonic with 0.01 M glucose solution. Percentage dissociation of K_2SO_4 is _____. (Nearest integer)

Official Ans. by NTA (75)

Sol. Isotonic solutions,

$$\pi_{\text{K}_2\text{SO}_4} = \pi_{\text{Glucose}}$$

$$i \times 0.004 \times RT = 0.01 \times RT$$

$$i = 2.5$$

For K_2SO_4 {for dissociation $i = 1 + (n - 1)\alpha$ }

$$\text{DOD}(\alpha) = \frac{i - 1}{n - 1} = \frac{2.5 - 1}{3 - 1} = 0.75$$

$$\% \text{ dissociation} = 75$$

90. In an electrochemical reaction of lead, at standard temperature, if $E_{(\text{Pb}^{2+}/\text{Pb})}^0 = m \text{ Volt}$ and $E_{(\text{Pb}^{4+}/\text{Pb})}^0 = n \text{ Volt}$, then the value of $E_{(\text{Pb}^{2+}/\text{Pb}^{4+})}^0$ is given by $m - xn$. The value of x is _____.

(Nearest integer)

Official Ans. by NTA (2)

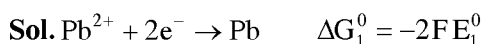

$$\Delta G_3^0 = \Delta G_1^0 - \Delta G_2^0$$

$$-2FE_3^0 = 2F(2n - m)$$

$$E_3^0 = m - 2n = m - xn$$

Hence $x = 2$