

FINAL JEE–MAIN EXAMINATION – APRIL, 2023**(Held On Thursday 13th April, 2023)****TIME : 3 : 00 PM to 6 : 00 PM****MATHEMATICS****TEST PAPER WITH SOLUTION****SECTION-A**

1. If the system of equations

$$2x + y - z = 5$$

$$2x - 5y + \lambda z = \mu$$

$$x + 2y - 5z = 7$$

has infinitely many solutions, then $(\lambda + \mu)^2 + (\lambda - \mu)^2$ is equal to

(1) 916

(2) 912

(3) 920

(4) 904

Official Ans. By NTA (1)**Sol.**

$$\begin{vmatrix} 2 & 1 & -1 \\ 2 & -5 & \lambda \\ 1 & 2 & -5 \end{vmatrix} = 0$$

$$2(25 - 2\lambda) - (-10 - \lambda) - (4 + 5) = 0$$

$$50 - 4\lambda + 10 + \lambda - 9 = 0$$

$$51 = 3\lambda \Rightarrow \lambda = 17$$

$$\begin{vmatrix} 2 & 1 & 5 \\ 2 & -5 & \mu \\ 1 & 2 & 7 \end{vmatrix} = 0$$

$$\Rightarrow 2(-35 - 2\mu) - (14 - \mu) + 5(4 + 5) = 0$$

$$-70 - 4\mu - 14 + \mu + 45 = 0$$

$$-3\mu = 39$$

$$-\mu = 13$$

$$(\lambda + \mu)^2 + (\lambda - \mu)^2 = 2(\lambda^2 + \mu^2)$$

$$= 2(17^2 + 13^2) = 916$$

2. The coefficient of
- x^5
- in the expansion of

$$\left(2x^3 - \frac{1}{3x^2}\right)^5$$
 is

(1) 8

(2) 9

(3) $\frac{80}{9}$

(4) $\frac{26}{3}$

Official Ans. By NTA (3)

Sol.
$$\left(2x^3 - \frac{1}{3x^2}\right)^5$$

$$T_{r+1} = {}^5C_r (2x^3)^{5-r} \left(\frac{-1}{3x^2}\right)^r = {}^5C_r \frac{(2)^{5-r}}{(-3)^r} (x)^{15-5r}$$

$$\therefore 15 - 5r = 5$$

$$\therefore r = 2$$

$$T_3 = 10 \left(\frac{8}{9}\right) x^5$$

So, coefficient is $\frac{80}{9}$

3. The plane, passing through the points (0, -1, 2) and (-1, 2, 1) and parallel to the line passing through (5, 1, -7) and (1, -1, -1), also passes through the point.

(1) (1, -2, 1)

(2) (0, 5, -2)

(3) (-2, 5, 0)

(4) (2, 0, 1)

Official Ans. By NTA (3)**Sol.** Points (0, -1, 2) and (-1, 2, 1) parallel to the line of (5, 1, -7) and (1, -1, -1)

$$\begin{matrix} \text{Normal} \\ \text{Vector} \end{matrix} = \begin{vmatrix} i & j & k \\ 4 & 2 & -6 \\ -1 & 3 & -1 \end{vmatrix}$$

$$\vec{n} = 16\hat{i} + 10\hat{j} + 14\hat{k}$$

$$16x + 10y + 14z = d$$

Point (0, -1, 2)

$$0 - 10 + 28 = d \Rightarrow d = 18$$

 $8x + 5y + 7z = 9$ is equation of plane.

4. Let α, β be the roots of the equation

$$x^2 - \sqrt{2}x + 2 = 0. \text{ Then } \alpha^{14} + \beta^{14} \text{ is equal to}$$

(1) $-64\sqrt{2}$

(2) $-128\sqrt{2}$

(3) -64

(4) -128

Official Ans. By NTA (4)

Sol. $x^2 - \sqrt{2}x + 2 = 0$

$$x = \frac{\sqrt{2} \pm \sqrt{2-8}}{2} = \frac{\sqrt{2} \pm \sqrt{6}i}{2}$$

$$\alpha = \frac{\sqrt{2} + \sqrt{6}i}{2} = \sqrt{2} e^{\frac{i\pi}{3}} \text{ \& } \beta = \sqrt{2} e^{\frac{-i\pi}{3}}$$

$$\alpha^{14} = 2^7 e^{\frac{i14\pi}{3}} = 128 \left[e^{\frac{i2\pi}{3}} \right]$$

$$\beta^{14} = 128 \left[e^{\frac{-i2\pi}{3}} \right]$$

$$\alpha^{14} + \beta^{14} = 128(2) \cos\left(\frac{2\pi}{3}\right) = -128$$

5. Let a_1, a_2, a_3, \dots be a G.P. of increasing positive numbers. Let the sum of its 6th and 8th terms be 2 and

the product of its 3rd and 5th terms be $\frac{1}{9}$. Then $6(a_2 +$

$a_4)(a_4 + a_6)$ is equal to

(1) $2\sqrt{2}$

(2) 2

(3) $3\sqrt{3}$

(4) 3

Official Ans. By NTA (4)

Sol.

$$ar^5 + ar^7 = 2$$

$$(ar^2)(ar^4) = \frac{1}{9}$$

$$a^2 r^6 = \frac{1}{9}$$

Now, $r > 0$

$$ar^5(1+r^2) = 2$$

$$\text{Now, } ar^3 = \frac{1}{3} \text{ or } -\frac{1}{3} \text{ (rejected)}$$

$$r^2 = 2$$

$$r = \sqrt{2}$$

$$a = \frac{1}{6\sqrt{2}}$$

Now, $6(a_2 + a_4)(a_4 + a_6)$

$$6(ar + ar^3)(ar^3 + ar^5)$$

$$6a^2r^4(1+r^2)$$

$$6\left(\frac{1}{36.2}\right)(4)(9) = 3$$

6. Let (α, β) be the centroid of the triangle formed by the lines $15x - y = 82$, $6x - 5y = -4$ and $9x + 4y = 17$. Then $\alpha + 2\beta$ and $2\alpha - \beta$ are the roots

of the equation

(1) $x^2 - 7x + 12 = 0$

(2) $x^2 - 13x + 42 = 0$

(3) $x^2 - 14x + 48 = 0$

(4) $x^2 - 10x + 25 = 0$

Official Ans. By NTA (2)

Sol. upon solving we get coordinates as $(6, 8)$, $(1, 2)$ and $(5, -7)$

So centroid : (α, β) is

$$\alpha = \frac{6+1+5}{3} = 4$$

$$\beta = \frac{8+2-7}{3} = 1$$

$$\alpha + 2\beta = 6$$

$$2\alpha - \beta = 7$$

$$\text{Ans. } x^2 - 13x + 42 = 0$$

7. Let $|\vec{a}|=2, |\vec{b}|=3$ and the angle between the vectors \vec{a} and \vec{b} be $\frac{\pi}{4}$. Then $\left|(\vec{a}+2\vec{b})\times(2\vec{a}-3\vec{b})\right|^2$ is

equal to

- (1) 482
- (2) 441
- (3) 841
- (4) 882

Official Ans. By NTA (4)

Sol. $|\vec{a}|=2, |\vec{b}|=3$

$$\left|(\vec{a}+2\vec{b})\times(2\vec{a}-3\vec{b})\right|^2$$

$$\left|-3\vec{a}\times\vec{b}+4\vec{b}\times\vec{a}\right|^2$$

$$\left|-3\vec{a}\times\vec{b}-4\vec{a}\times\vec{b}\right|^2$$

$$\left|-7\vec{a}\times\vec{b}\right|^2$$

$$\left(-7|\vec{a}|\times|\vec{b}|\sin\left(\frac{\pi}{4}\right)\right)^2$$

$$49\times 4\times 9\times \frac{1}{2}=882$$

8. Let N be the foot of perpendicular from the point P (1, -2, 3) on the line passing through the points (4, 5, 8) and (1, -7, 5). Then the distance of N from the plane $2x-2y+z+5=0$ is

- (1) 6
- (2) 9
- (3) 7
- (4) 8

Official Ans. By NTA (3)

Sol.

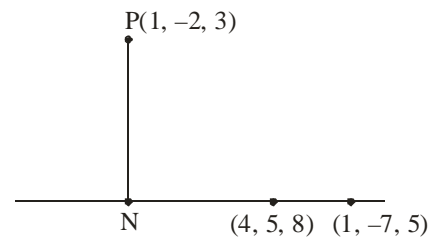

Equation of line

$$\frac{x-4}{4-1}=\frac{y-5}{5-(-7)}=\frac{z-8}{8-5}$$

$$\frac{x-4}{3}=\frac{y-5}{12}=\frac{z-8}{3}$$

Let point N(3λ + 4, 12λ + 5, 3λ + 8)

$$\vec{PN}=(3\lambda+4-1)\hat{i}+(12\lambda+5-(-2))\hat{j}+(3\lambda+8-3)\hat{k}$$

$$\vec{PN}=(3\lambda+3)\hat{i}+(12\lambda+7)\hat{j}+(3\lambda+5)\hat{k}$$

And parallel vector to line (say $\vec{a}=3\hat{i}+12\hat{j}+3\hat{k}$)

Now, $\vec{PN}\cdot\vec{a}=0$

$$(3\lambda+3)3+(12\lambda+7)12+(3\lambda+5)3=0$$

$$162\lambda+108=0\Rightarrow\lambda=\frac{-108}{162}=\frac{-2}{3}$$

So point N is (2, -3, 6)

$$\text{Now distance is}=\left|\frac{2(2)-2(-3)+6+5}{\sqrt{4+4+1}}\right|=7$$

9. If $\lim_{x\rightarrow 0}\frac{e^{ax}-\cos(bx)-\frac{cxe^{-cx}}{2}}{1-\cos(2x)}=17$, then $5a^2+b^2$ is

equal to

- (1) 72
- (2) 76
- (3) 68
- (4) 64

Official Ans. By NTA (3)

$$\text{Sol. } \lim_{x \rightarrow 0} \frac{e^{ax} - \cos(bx) - \frac{cxe^{-cx}}{2}}{\frac{(1 - \cos 2x)}{4x^2} \times 4x^2} = 17$$

On expansion,

$$\lim_{x \rightarrow 0} \frac{\left(1 + ax + \frac{a^2 x^2}{2}\right) - \left(1 - \frac{b^2 x^2}{2}\right) - \frac{cx}{2}(1 - cx)}{2x^2} = 17$$

$$\lim_{x \rightarrow 0} \frac{\left(a - \frac{c}{2}\right)x + x^2 \left(\frac{a^2}{2} + \frac{b^2}{2} + \frac{c^2}{2}\right)}{2x^2} = 17$$

For limit to be exist $a - \frac{c}{2} = 0$

$$a = \frac{c}{2}$$

and $\frac{a^2 + b^2 + c^2}{4} = 17$

$$a^2 + b^2 + 4a^2 = 17 \times 4$$

$$5a^2 + b^2 = 68$$

- 10.** Let the centre of a circle C be (α, β) and its radius $r < 8$. Let $3x + 4y = 24$ and $3x - 4y = 32$ be two tangents and $4x + 3y = 1$ be a normal to C. Then $(\alpha - \beta + r)$ is equal to
- (1) 7
 - (2) 9
 - (3) 5
 - (4) 6

Official Ans. By NTA (1)

Sol.

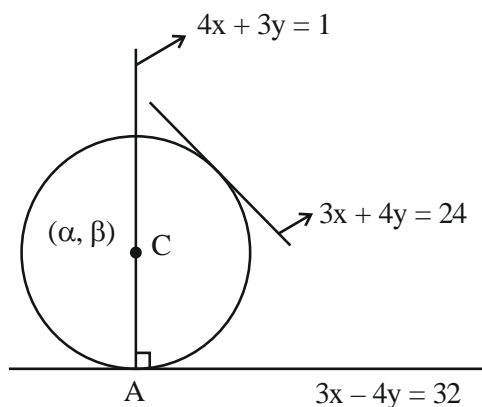

First find point A by solving $4x + 3y = 1$ and $3x - 4y = 32$

After solving, point A is $(4, -5)$

centre (α, β) lie on $4x + 3y = 1$

$$4\alpha + 3\beta = 1 \Rightarrow \beta = \frac{1 - 4\alpha}{3}$$

Now distance from centre to line $3x - 4y - 32 = 0$ and $3x + 4y - 24 = 0$ are equal.

$$\left| \frac{3\alpha - 4\left(\frac{1 - 4\alpha}{3}\right) - 32}{5} \right| = \left| \frac{3\alpha + 4\left(\frac{1 - 4\alpha}{3}\right) - 24}{5} \right|$$

after solving $\alpha = 1$ and $\alpha = \frac{28}{3}$

For $\alpha = 1$, centre $(1, -1) \Rightarrow$ radius = 5

For $\alpha = \frac{28}{3}$, centre $\left(\frac{28}{3}, \frac{-109}{2}\right)$

\Rightarrow radius ≈ 49.78 (rejected)

Hence, $\alpha = 1, \beta = -1, r = 5$

$$\alpha - \beta + r = 7$$

- 11.** All words, with or without meaning, are made using all the letters of the word MONDAY. These words are written as in a dictionary with serial numbers. The serial number of the word MONDAY is

- (1) 327
- (2) 326
- (3) 328
- (4) 324

Official Ans. By NTA (1)

Sol. First arrange in alphabetical order

i.e. ADMNOY

$$\underline{A} \text{ -----} = 5!$$

$$\underline{D} \text{ -----} = 5!$$

$$\boxed{M} \underline{A} \text{ -----} = 4!$$

$$\boxed{M} \underline{D} \text{ -----} = 4!$$

$$\boxed{M} \underline{N} \text{ -----} = 4!$$

$$\boxed{M} \quad \boxed{O} \quad \underline{A} \text{ ---} = 3!$$

$$\boxed{M} \quad \boxed{O} \quad \underline{D} \text{ ---} = 3!$$

$$\boxed{M} \quad \boxed{O} \quad \boxed{N} \quad \underline{A} \text{ --} = 2!$$

$$\boxed{M} \quad \boxed{O} \quad \boxed{N} \quad \boxed{D} \quad \boxed{A} \quad \boxed{Y} = 1$$

$$= 327$$

12. The range of $f(x) = 4 \sin^{-1} \left(\frac{x^2}{x^2+1} \right)$ is

- (1) $[0, \pi]$
- (2) $[0, 2\pi]$
- (3) $[0, \pi)$
- (4) $[0, 2\pi]$

Official Ans. By NTA (2)

Sol. $f(x) = 4 \sin^{-1} \left(\frac{x^2}{x^2+1} \right)$

$$\frac{x^2+1-1}{x^2+1} = 1 - \frac{1}{x^2+1} \Rightarrow [0, 1)$$

Range of $f(x) = [0, 2\pi)$

13. The statement

$(p \wedge (\sim q) \vee ((\sim p) \wedge q) \vee ((\sim p) \wedge (\sim q)))$ is equivalent to

- (1) $(\sim p) \vee (\sim q)$
- (2) $p \vee (\sim q)$
- (3) $(\sim p) \vee q$
- (4) $p \vee q$

Official Ans. By NTA (1)

Sol. $(p \wedge (\sim q) \vee ((\sim p) \wedge q) \vee ((\sim p) \wedge (\sim q)))$

$$(p \wedge (\sim q)) \vee ((\sim p) \wedge (q \vee (\sim q)))$$

$$(p \wedge (\sim q)) \vee ((\sim p) \wedge t)$$

$$(p \wedge (\sim q)) \vee (\sim p)$$

$$(\sim p) \vee (p \wedge \sim q)$$

$$(\sim p \vee p) \wedge (\sim p \vee \sim q)$$

$$t \wedge (\sim p \vee \sim q)$$

$$= \sim p \vee \sim q$$

14. The random valuable X follows binomial distribution B (n, p) for which the difference of the mean and the variance is 1. If $2P(X = 2) = 3P(X = 1)$, then $n^2 P(X > 1)$ is equal to

- (1) 12
- (2) 15
- (3) 11
- (4) 16

Official Ans. By NTA (3)

Sol. $np - npq = 1$

$$\Rightarrow np^2 = 1$$

$$2^n C_2 p^2 q^{n-2} = 3^n C_1 p q^{n-1}$$

$$\Rightarrow np - p = 3q \quad (\because q = 1 - p)$$

$$\Rightarrow p = \frac{1}{2}$$

Hence $n = 4$

$$P(x > 1) = 1 - (p(x = 0) + p(x = 1))$$

$$= 1 - \left({}^4C_0 \left(\frac{1}{2} \right)^4 + {}^4C_1 \left(\frac{1}{2} \right)^1 \left(\frac{1}{2} \right)^3 \right) = \frac{11}{16}$$

15. Let for $A = \begin{bmatrix} 1 & 2 & 3 \\ a & 3 & 1 \\ 1 & 1 & 2 \end{bmatrix}$, $|A| = 2$. If $|2\text{adj}(2\text{adj}(2A))|$

$= 32^n$, then $3n + \alpha$ is equal to

- (1) 10
- (2) 9
- (3) 12
- (4) 11

Official Ans. By NTA (4)

Sol. $A = \begin{bmatrix} 1 & 2 & 3 \\ a & 3 & 1 \\ 1 & 1 & 2 \end{bmatrix}$ $|A| = 2,$

$$1(6-1) - 2(2\alpha-1) + 3(\alpha-3) = 2$$

$$5 - 4\alpha + 2 + 3\alpha - 9 = 2$$

$$-\alpha - 4 = 0$$

$$\alpha = -4$$

$$8|\text{Adj}(2\text{Adj}(2A))|$$

$$8|\text{Adj}(2 \times 2^2 \text{Adj}(A))|$$

$$8|\text{Adj}(2^3 \text{Adj}A)|$$

$$8|2^6 \text{Adj}(\text{Adj}A)|$$

$$2^3(2^6)^3 |\text{Adj}(\text{Adj}A)|$$

$$2^3 \cdot 2^{18} |A|^4$$

$$2^{21} \cdot 2^4 = 2^{25} = (2^5)^5 = (32)^5$$

$$n = 5$$

$$\alpha = -4$$

16. Let $S = \{Z \in C : \bar{z} = i(z^2 + \text{Re}(\bar{z}))\}$. Then $\sum_{z \in S} |z|^2$

is equal to

(1) $\frac{7}{2}$

(2) 4

(3) $\frac{5}{2}$

(4) 3

Official Ans. By NTA (2)

Sol. Let $Z = x + iy$, $x \in R$, $y \in R$

$$x - iy = i(x^2 - y^2 + (2xy)i + x)$$

$$\mathbf{x = -2xy} \quad \dots(1)$$

$$-y = -y^2 + x^2 + x \quad \dots(2)$$

$$\Rightarrow x = 0, y = -\frac{1}{2} \text{ (from (1))}$$

If $x \neq 0$, then $y = 0, 1$

$$\text{If } y = -\frac{1}{2}, \text{ then } x = \frac{1}{2}, -\frac{3}{2}$$

$$Z = 0 + i0, 0 + i, \frac{1}{2} - \frac{i}{2}, -\frac{3}{2} - \frac{i}{2}$$

17. The area of the region

$$\{(x, y) : x^2 \leq y \leq |x^2 - 4|, y \geq 1\}$$
 is

(1) $\frac{3}{4}(4\sqrt{2} - 1)$

(2) $\frac{4}{3}(4\sqrt{2} - 1)$

(3) $\frac{4}{3}(4\sqrt{2} + 1)$

(4) $\frac{3}{4}(4\sqrt{2} + 1)$

Official Ans. By NTA (2)

Sol.

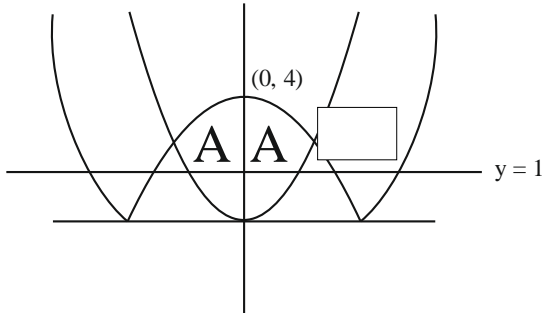

$$\text{Required area} = 2 \left[\int_1^2 \sqrt{y} \, dy + \int_2^4 \sqrt{4-y} \, dy \right] = \frac{4}{3} [4\sqrt{2} - 1]$$

18. Let for a triangle ABC,

$$\overline{AB} = -2\hat{i} + \hat{j} + 3\hat{k}$$

$$\overline{CB} = \alpha\hat{i} + \beta\hat{j} + \gamma\hat{k}$$

$$\overline{CA} = 4\hat{i} + 3\hat{j} + \delta\hat{k}$$

If $\delta > 0$ and the area of the triangle ABC is $5\sqrt{6}$, then $\overline{CB} \cdot \overline{CA}$ is equal to

- (1) 60
- (2) 120
- (3) 108
- (4) 54

Official Ans. By NTA (1)

Sol. $\overline{AB} + \overline{BC} + \overline{CA} = \vec{0}$

$$\alpha = 2, \beta = 4, \gamma - \delta = 3$$

$$\frac{1}{2} |\overline{AB} \times \overline{AC}| = 5\sqrt{6}$$

$$(\delta - 9)^2 + (2\delta + 12)^2 + 100 = 600$$

$$\Rightarrow \delta = 5, \gamma = 8$$

$$\text{Hence } \overline{CB} \cdot \overline{CA} = 60$$

19. The line, that is coplanar to the line

$$\frac{x+3}{-3} = \frac{y-1}{1} = \frac{z-5}{5}, \text{ is}$$

$$(1) \frac{x+1}{1} = \frac{y-2}{2} = \frac{z-5}{5}$$

$$(2) \frac{x+1}{-1} = \frac{y-2}{2} = \frac{z-5}{5}$$

$$(3) \frac{x+1}{-1} = \frac{y-2}{2} = \frac{z-5}{4}$$

$$(4) \frac{x-1}{-1} = \frac{y-2}{2} = \frac{z-5}{5}$$

Official Ans. By NTA (2)

Sol. Condition of co-planarity

$$\begin{vmatrix} x_2 - x_1 & a_1 & a_2 \\ y_2 - y_1 & b_1 & b_2 \\ z_2 - z_1 & c_1 & c_2 \end{vmatrix} = 0$$

Where a_1, b_1, c_1 are direction cosine of 1st line and a_2, b_2, c_2 are direction cosine of 2nd line.

Now, solving options

Point $(-3, 1, 5)$ & point $(-1, 2, 5)$

$$(1) \begin{vmatrix} -3 & 1 & 5 \\ 1 & 2 & 5 \\ -2 & -1 & 0 \end{vmatrix}$$

$$= -3(5) - (10) + 5(-1 + 4)$$

$$= -15 - 10 + 15 = -10$$

(2) Point $(-1, 2, 5)$

$$\begin{vmatrix} -3 & 1 & 5 \\ -1 & 2 & 5 \\ -2 & -1 & 0 \end{vmatrix}$$

$$= 3(5) - (10) + 5(1 + 4)$$

$$-25 + 25 = 0$$

(3) Point $(-1, 2, 5)$

$$\begin{vmatrix} -3 & 1 & 5 \\ -1 & 2 & 4 \\ -2 & -1 & 0 \end{vmatrix}$$

$$-3(4) - (8) + 5(1 + 4)$$

$$-12 - 8 + 25 = 5$$

(4) Point $(-1, 2, 5)$

$$\begin{vmatrix} -3 & 1 & 5 \\ -1 & 2 & 5 \\ 4 & 1 & 0 \end{vmatrix}$$

$$-3(-5) - (-20) + 5(-1 - 8)$$

$$15 + 20 - 45 = -10$$

20. The value of $\frac{e^{-\frac{\pi}{4}} + \int_0^{\frac{\pi}{4}} e^{-x} \tan^{50} x dx}{\int_0^{\frac{\pi}{4}} e^{-x} (\tan^{49} x + \tan^{51} x) dx}$ is

- (1) 50
 (2) 49
 (3) 51
 (4) 25

Official Ans. By NTA (1)

Sol. $\int_0^{\pi/4} e^{-x} \tan^{50} x dx$

$$\left[-e^{-y} (\tan x)^{50} \right]_0^{\pi/4} + \int_0^{\pi/4} e^{-x} (50) (\tan x)^{49} \sec^2 x$$

$$= -e^{-\pi/4} + 0 + 50 \int_0^{\pi/4} e^{-x} (\tan x)^{49} (\tan^2 x + 1)$$

$$= -e^{-\pi/4} + 50 \left(\int_0^{\pi/4} e^{-x} (\tan x)^{51} + (\tan x)^{49} \right) dx$$

Now, $\frac{-e^{-\pi/4} + \int_0^{\pi/4} e^{-x} (\tan x)^{50} dx}{\int_0^{\pi/4} e^{-x} (\tan^{49} x + \tan^{51} x) dx}$

$$\frac{50 \int_0^{\pi/4} e^{-x} ((\tan x)^{51} + (\tan x)^{49}) dx}{\int_0^{\pi/4} e^{-x} (\tan^{49} x + \tan^{51} x) dx} = 50$$

SECTION-B

21. The mean and standard deviation of the marks of 10 students were found to be 50 and 12 respectively. Later, it was observed that two marks 20 and 25 were wrongly read as 45 and 50 respectively. Then the correct variance is _____.

Official Ans. by NTA (269)

Sol. $\bar{x} = 50$

$$\sum x_i = 500$$

$$\sum x_{i \text{ correct}} = 500 + 20 + 25 - 45 - 50 = 450$$

$$\sigma^2 = 144$$

$$\frac{\sum x_i^2}{10} - (50)^2 = 144$$

$$\sum x_{i \text{ correct}}^2 = (144 + (50)^2) \times 10 - (45)^2 - (50)^2 + (20)^2 + (25)^2 = 22940$$

$$\text{Correct variance} = \frac{\sum (x_{i \text{ correct}})^2}{10} - \left(\frac{\sum x_{i \text{ correct}}}{10} \right)^2$$

$$= 2294 - (45)^2$$

$$= 2294 - 2025 = 269$$

22. Let $A = \{-4, -3, -2, 0, 1, 3, 4\}$ and $R = \{(a, b) \in A \times A : b = |a| \text{ or } b^2 = a + 1\}$ be a relation on A. Then the minimum number of elements, that must be added to the relation R so that it becomes reflexive and symmetric, is _____.

Official Ans. by NTA (7)

Sol. $R = [(-4, 4), (-3, 3), (3, -2), (0, 1), (0, 0), (1, 1), (4, 4), (3, 3)]$

For reflexive, add $\Rightarrow (-2, -2), (-4, -4), (-3, -3)$

For symmetric, add $\Rightarrow (4, -4), (3, -3), (-2, 3), (1, 0)$

23. Let $f(x) = \sum_{k=1}^{10} kx^k$, $x \in \mathbb{R}$. If $2f(2) + f(2) = 119(2)^n + 1$ then n is equal to _____.

Official Ans. by NTA (10)

Sol. $f(x) = \sum_{k=1}^{10} kx^k$

$$f(x) = x + 2x^2 + \dots + 10x^{10}$$

$$f(x) \cdot x = x^2 + 2x^3 + \dots + 9x^{10} + 10x^{11}$$

$$f(x)(1-x) = x + x^2 + x^3 + \dots + x^{10} - 10x^{11}$$

$$f(x) = \frac{x(1-x^{10})}{(1-x)^2} - \frac{10x^{11}}{(1-x)}$$

$$f(x) = \frac{x - x^{11} - 10x^{11} + 10x^{12}}{(1-x)^2} \Rightarrow \frac{10x^{12} - 11x^{11} + x}{(1-x)^2}$$

Hence $2f(2) + f(2) = 119 \cdot 2^{10} + 1$

\Rightarrow So, $n = 10$

24. Total numbers of 3-digit numbers that are divisible by 6 and can be formed by using the digits 1, 2, 3, 4, 5 with repetition, is _____.

Official Ans. by NTA (16)

Sol. For number to be divisible by '6' unit digit should be even and sum of digit is divisible by 3.

(2, 1, 3), (2, 3, 4), (2, 5, 5), (2, 2, 5), (2, 2, 2),
(4, 1, 1), (4, 4, 1), (4, 4, 4), (4, 3, 5)

$2, 1, 3 \Rightarrow 312, 132$

$2, 3, 4 \Rightarrow 342, 432, 234, 324$

$2, 5, 5 \Rightarrow 552$

$2, 2, 5 \Rightarrow 252, 522$

$2, 2, 2 \Rightarrow 222$

$4, 1, 1 \Rightarrow 114$

$4, 4, 1 \Rightarrow 414, 144$

$4, 4, 4 \Rightarrow 444$

$4, 3, 5 \Rightarrow 354, 534$

Total 16 numbers.

25. Let $[\alpha]$ denote the greatest integer $\leq \alpha$. Then $[\sqrt{1}] + [\sqrt{2}] + [\sqrt{3}] + \dots + [\sqrt{120}]$ is equal to.

Official Ans. by NTA (825)

Sol. $[\sqrt{1}] + [\sqrt{2}] + [\sqrt{3}] + \dots + [\sqrt{120}]$

$\Rightarrow 1 + 1 + 1 + 2 + 2 + 2 + 2 + 2 + 3 + 3 + \dots + 3 = 7$ times

$+ 4 + 4 + \dots + 4 = 9$ times $+ \dots + 10 + 10 + \dots + 10 = 21$ times

$\Rightarrow \sum_{r=1}^{10} (2r + 1) \cdot r$

$\Rightarrow 2 \sum_{r=1}^{10} r^2 + \sum_{r=1}^{10} r$

$\Rightarrow 2 \times \frac{10 \times 11 \times 21}{6} + \frac{10 \times 11}{2}$

$\Rightarrow 770 + 55$

$\Rightarrow 825$

26. For $x \in (-1, 1]$, the number of solutions of the equation $\sin^{-1}x = 2 \tan^{-1}x$ is equal to

Official Ans. by NTA (2)

Sol.

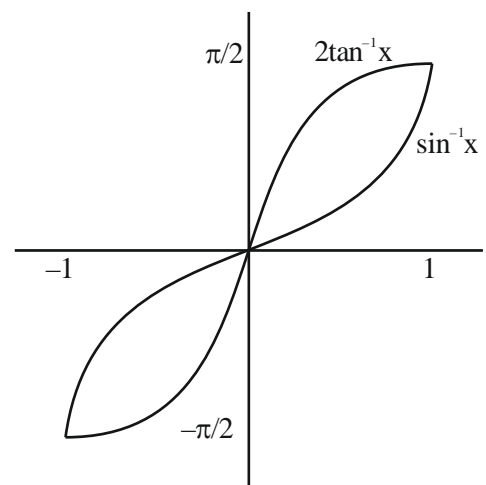

27. If $y = y(x)$ is the solution of the differential equation $\frac{dy}{dx} + \frac{4x}{(x^2-1)}y = \frac{x+2}{(x^2-1)^{\frac{5}{2}}}$, $x > 1$ such

that $y(2) = \frac{2}{9} \log_e(2 + \sqrt{3})$ and $y(\sqrt{2}) = \alpha \log_e(\sqrt{\alpha} + \beta) + \beta - \sqrt{\gamma}$, $\alpha, \beta, \gamma \in \mathbb{N}$, then $\alpha\beta\gamma$ is equal to _____.

Official Ans. by NTA (6)

Sol. $\frac{dy}{dx} + \frac{4x}{(x^2-1)}y = \frac{x+2}{(x^2-1)^{\frac{5}{2}}}$, $x > 1$

I.F. = $e^{\int \frac{4x}{x^2-1} dx}$

I.F. = $(x^2-1)^2$

$\Rightarrow d(y \cdot (x^2-1)^2) = \frac{x+2}{(x^2-1)^{\frac{5}{2}}} \cdot (x^2-1)^2 dx$

$\Rightarrow \int d(y \cdot (x^2-1)^2) = \int \frac{x+2}{(x^2-1)^{\frac{1}{2}}} dx$ _____ (1)

$y(x^2-1)^2 = \sqrt{x^2-1} + 2 \ln(x + \sqrt{x^2-1}) + C$

$\Rightarrow C = -\sqrt{3}$

So $(x^2-1)^2 = \sqrt{x^2-1} + 2 \ln(x + \sqrt{x^2-1}) - \sqrt{3}$

$\Rightarrow \alpha\beta\gamma = 6$

28. The foci of a hyperbola are $(\pm 2, 0)$ and its eccentricity is $\frac{3}{2}$. A tangent, perpendicular to the line $2x + 3y = 6$, is drawn at a point in the first quadrant on the hyperbola. If the intercepts made by the tangent on the x- and y-axes are a and b respectively, then $|6a| + |5b|$ is equal to _____.

Official Ans. by NTA (12)

Sol. $\frac{x^2}{a^2} - \frac{y^2}{b^2} = 1$

$ae = 2$ & $e = \frac{3}{2} \Rightarrow a = \frac{4}{3}$

also $b^2 = a^2 e^2 - a^2 \Rightarrow 4 - \frac{16}{9}$

$\Rightarrow b^2 = \frac{20}{9}$

Slope of tangent = $\frac{3}{2}$

So tangent equation will be

$y = mx \pm \sqrt{a^2 m^2 - b^2}$

$\Rightarrow y = \frac{3x}{2} \pm \sqrt{\frac{16}{9} \cdot \frac{9}{4} - \frac{20}{9}}$

$\Rightarrow y = \frac{3x}{2} \pm \frac{4}{3} \Rightarrow |x_{\text{intercept}}| = \frac{8}{9}$

$|y_{\text{intercept}}| = \frac{4}{3}$

$\Rightarrow |6a| + |5b| = \frac{48}{9} + \frac{60}{9} = \frac{109}{9} = 12$

29. Let $f_n = \int_0^{\frac{\pi}{2}} \left(\sum_{k=1}^n \sin^{k-1} x \right) \left(\sum_{k=1}^n (2k-1) \sin^{k-1} x \right) \cos x dx$, $n \in \mathbb{N}$. Then $f_{21} - f_{20}$ is equal to _____.

Official Ans. by NTA (41)

Sol.

$f_n(x) = \int_0^{\frac{\pi}{2}} (1 + \sin x + \sin^2 x + \sin^3 x + \dots + \sin^{n-1} x) \cos x dx$

$(1 + 3\sin x + 5\sin^2 x + \dots + (2n-1)\sin^{n-1} x) \cos x dx$

Multiply & divide by $\sqrt{\sin x}$

$\int_0^{\frac{\pi}{2}} \left((\sin x)^{\frac{1}{2}} + (\sin x)^{\frac{3}{2}} + (\sin x)^{\frac{5}{2}} + (\sin x)^{\frac{7}{2}} + \dots + (\sin x)^{\frac{2n-1}{2}} \right) \cos x dx$

$(1 + 3\sin x + 5\sin^2 x + \dots + (2n-1)\sin^{n-1} x) \frac{\cos x}{\sqrt{\sin x}} dx$

Put $(\sin x)^{1/2} + (\sin x)^{3/2} + (\sin x)^{5/2} + \dots + (\sin x)^{n-1/2} = t$

$\frac{1}{2} \frac{(1 + 3\sin x + 5\sin^2 x + \dots + (2n-1)\sin^{n-1} x) \cos x dx}{\sqrt{\sin x}} = dt$

$f_n = 2 \int_0^n t dt$

$f_n = n^2$

$f_{21} - f_{20} = (21)^2 - (20)^2$

$= 441 - 400$

$= 41$

30. The remainder, when 7^{103} is divided by 17 is ____.

Official Ans. by NTA (12)

Sol. $7^{103} = 7 \times 7^{102}$

$$= 7 \times (49)^{51}$$

$$= 7 \times (51 - 2)^{51}$$

Remainder :- $7 \times (-2)^{51}$

$$\Rightarrow -7 (2^3 \cdot (16)^{12})$$

$$\Rightarrow -56 (17 - 1)^{12}$$

$$\text{Remainder} = -56 \times (-1)^{12} = -56 + 68 = 12$$

PHYSICS

TEST PAPER WITH SOLUTION

SECTION-A

31. Given below are two statements : one is labelled as **Assertion A** and the other is labelled as **Reason R**

Assertion A : The binding energy per nucleon is practically independent of the atomic number for nuclei of mass number in the range 30 to 170.

Reason R : Nuclear force is short ranged.

In the light of the above statements, choose the **correct** answer from the options given below

Option :

- (1) Both **A** and **R** are true but **R** is **NOT** the correct explanation of **A**
- (2) **A** is true but **R** is false
- (3) **A** is false but **R** is true
- (4) Both **A** and **R** are true and **R** is the correct explanation of **A**

Official Ans. by NTA (4)

Sol. Binding energy per nucleon is almost same for nuclei of mass number ranging 30 to 170.

32. The output from a NAND gate having inputs A and B given below will be.

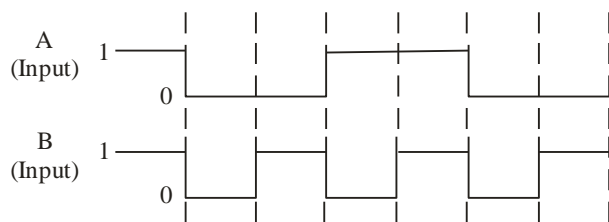

Option :

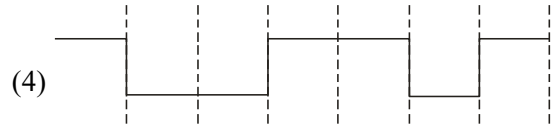
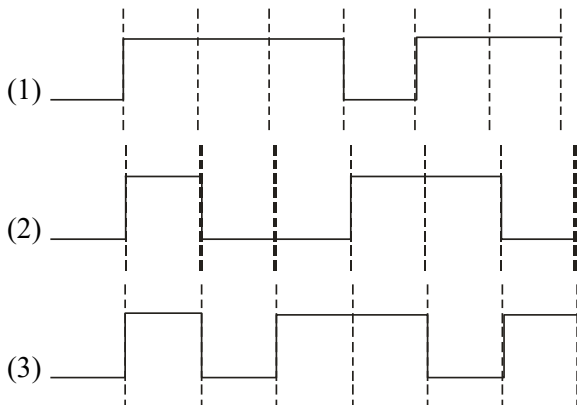

Official Ans. by NTA (1)

Sol. Truth table for NAND gate is

| A | B | $Y = \overline{A \cdot B}$ |
|---|---|----------------------------|
| 0 | 0 | 1 |
| 0 | 1 | 1 |
| 1 | 0 | 1 |
| 1 | 1 | 0 |

On the basis of given input A and B the truth table is

| A | B | Y |
|---|---|---|
| 1 | 1 | 0 |
| 0 | 0 | 1 |
| 0 | 1 | 1 |
| 1 | 0 | 1 |
| 1 | 1 | 0 |
| 0 | 0 | 1 |
| 0 | 1 | 1 |

So the correct answer is Option 1.

33. In the network shown below, the charge accumulated in the capacitor in steady state will be :

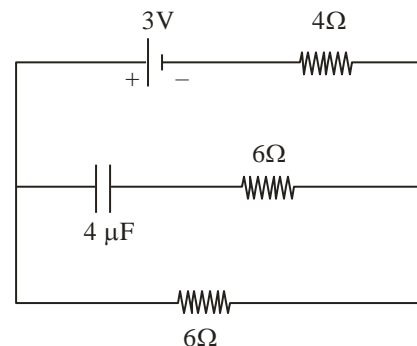

Option :

- (1) 7.2 μC
- (2) 4.8 μC
- (3) 10.3 μC
- (4) 12 μC

Official Ans. by NTA (1)

Sol.

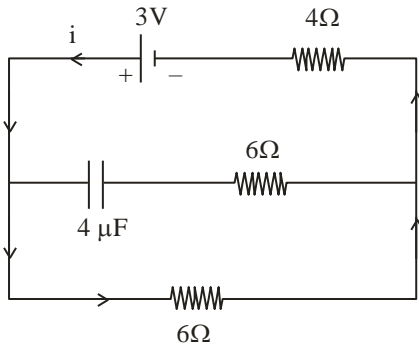

No current will flow in capacitor in steady state, current flowing in the circuit in steady state

$$I = \frac{3}{6 + 4} = \frac{3}{10}$$

Potential difference on 6Ω resistance

$$V = 6 \times \frac{3}{10} = 1.8 \text{ volt}$$

Capacitor will have same potential so charge,

$$q = CV = (4 \mu\text{F}) \cdot (1.8 \text{ volt}) = 7.2 \mu\text{C}$$

34. Given below are two statements :

Statement I: For a planet, if the ratio of mass of the planet to its radius increases, the escape velocity from the planet also increases.

Statement II: Escape velocity is independent of the radius of the planet.

In the light of above statements, choose the **most appropriate** answer from the options given below

Option :

- (1) Both Statement I and Statement II are incorrect
- (2) Statement I is correct but statement II is incorrect
- (3) Statement I is incorrect but statement II is correct
- (4) Both Statement I and Statement II are correct

Official Ans. by NTA (2)

Sol. $V_e = \sqrt{\frac{2GM}{R}} \Rightarrow V_e \propto \sqrt{\frac{M}{R}}$

As $\frac{M}{R}$ increases $\Rightarrow V_e$ increases

Statement (1) is correct

Also $V_e \propto \frac{1}{\sqrt{R}}$

As V_e depends upon R

\Rightarrow Statement (2) is incorrect

Option (2) is correct

35. A particle executes SHM of amplitude A . The distance from the mean position when its kinetic energy becomes equal to its potential energy is :

Option :

- (1) $\sqrt{2}A$
- (2) $2A$
- (3) $\frac{1}{\sqrt{2}}A$
- (4) $\frac{1}{2}A$

Official Ans. by NTA (3)

Sol. $KE = PE$

$$\frac{1}{2} M\omega^2(A^2 - x^2) = \frac{1}{2} M\omega^2 x^2$$

$$A^2 - x^2 = x^2 \Rightarrow A^2 = 2 \times 2$$

$$\Rightarrow x = \pm \frac{A}{\sqrt{2}}$$

36. A passenger sitting in a train A moving at 90 km/h observes another train B moving in the opposite direction for 8 s. If the velocity of the train B is 54 km/h, then length of train B is :

Option :

- (1) 80 m
- (2) 200 m
- (3) 120 m
- (4) 320 m

Official Ans. by NTA (4)

Sol. Velocity of train A

$$V_A = 90 \frac{\text{km}}{\text{hr}} = 90 \times \frac{5}{18} = 25 \text{ m/s}$$

Velocity of train B

$$V_B = 54 \frac{\text{km}}{\text{hr}} = 54 \times \frac{5}{18} = 15 \text{ m/s}$$

$$\text{Velocity of train B w.r.t. train A} = \vec{V}_B - \vec{V}_A$$

$$= 15 - (-25) \text{ m/s}$$

$$= 40 \text{ m/s}$$

$$\text{Time of crossing} = \frac{\text{length of train}}{\text{relative velocity}}$$

$$(8) = \frac{\ell}{40}$$

$$\ell = 8 \times 40 = 320 \text{ meter.}$$

37. The initial pressure and volume of an ideal gas are P_0 and V_0 . The final pressure of the gas when the gas is suddenly compressed to volume $\frac{V_0}{4}$ will be :
(Given γ = ratio of specific heats at constant pressure and at constant volume)

Option :

- (1) $P_0(4)^\gamma$ (2) $P_0(4)^\gamma$
(3) P_0 (4) $4P_0$

Official Ans. by NTA (2)

Sol. As gas is suddenly compressed, the process is adiabatic.

Equation of gas for adiabatic process is $PV^\gamma = \text{constant}$.

$$\Rightarrow P_1 V_1^\gamma = P_2 V_2^\gamma$$

$$\Rightarrow P_0 V_0^\gamma = P_2 \left(\frac{V_0}{4}\right)^\gamma$$

$$\Rightarrow P_2 = P_0(4)^\gamma$$

Option (2) is correct

38. Given below are two statements: one is labelled as **Assertion A** and the other is labelled as **Reason R**
Assertion A : A spherical body of radius (5 ± 0.1) mm having a particular density is falling through a liquid of constant density. The percentage error in the calculation of its terminal velocity is 4%.

Reason R : The terminal velocity of the spherical body falling through the liquid is inversely proportional to its radius.

In the light of the above statements, choose the **correct** answer from the options given below

Option :

- (1) Both **A** and **R** are true but **R** is **NOT** the correct explanation of **A**
(2) Both **A** and **R** are true and **R** is the correct explanation of **A**
(3) **A** is false but **R** is true
(4) **A** is true but **R** is false

Official Ans. by NTA (4)

Sol. Terminal velocity of a spherical body in liquid

$$\Rightarrow V_t \propto r^2$$

$$\Rightarrow \frac{\Delta V_t}{V_t} = 2 \cdot \frac{\Delta r}{r}$$

$$\Rightarrow \frac{\Delta V_t}{V_t} \times 100\% = 2 \frac{(0.1)}{5} \times 100 = 4\%$$

$$\text{Also } V_t \propto r^2$$

Reason R is false

Option (4) is correct

39. In an electromagnetic wave, at an instant and at a particular position, the electric field is along the negative z-axis and magnetic field is along the positive x-axis. Then the direction of propagation of electromagnetic wave is :

Option :

- (1) at 45° angle from positive y-axis
(2) negative y-axis
(3) positive z-axis
(4) positive y-axis

Official Ans. by NTA (2)

Sol. Direction of propagation of EM wave will be in the direction of $\vec{E} \times \vec{B}$.

40. The distance travelled by an object in time t is given by $s = (2.5)t^2$. The instantaneous speed of the object at $t = 5$ s will be :

Option :

- (1) 12.5 ms^{-1} (2) 62.5 ms^{-1}
(3) 5 ms^{-1} (4) 25 ms^{-1}

Official Ans. by NTA (4)

Sol. Distance $(s) = (2.5)t^2$

$$\text{Speed } (v) = \frac{ds}{dt} = \frac{d}{dt} \{(2.5)t^2\}$$

$$v = 5t$$

$$\text{At } t = 5, v = 5 \times 5 = 25 \text{ m/s.}$$

Option (4) is correct

41. An electron is moving along the positive x-axis. If the uniform magnetic field is applied parallel to the negative z-axis. then
- The electron will experience magnetic force along positive y-axis
 - The electron will experience magnetic force along negative y-axis
 - The electron will not experience any force in magnetic field
 - The electron will continue to move along the positive x-axis
 - The electron will move along circular path in magnetic field
- Choose the correct answer from the options given below :

Option :

- | | |
|------------------|------------------|
| (1) B and E only | (2) A and E only |
| (3) C and D only | (4) B and D only |

Official Ans. by NTA (1)

Sol. $\vec{F} = -e(\vec{v} \times \vec{B})$

Force will be along $-ve$ y-axis.

As magnetic force is \perp to velocity, path of electron must be a circle.

42. Two planets A and B of radii R and 1.5 R have densities ρ and $\rho/2$ respectively. The ratio of acceleration due to gravity at the surface of B to A is :

Option :

- | | |
|-----------|-----------|
| (1) 2 : 3 | (2) 2 : 1 |
| (3) 3 : 4 | (4) 4 : 3 |

Official Ans. by NTA (3)

Sol. $g = \frac{GM}{R^2} = \frac{4}{3} \pi G \rho R$

$$\therefore \frac{g_2}{g_1} = \frac{\rho_2}{\rho_1} \times \frac{R_2}{R_1} = \frac{1}{2} \times 1.5 = \frac{3}{4}$$

43. Given below are two statements:

Statement I : An AC circuit undergoes electrical resonance if it contains either a capacitor or an inductor.

Statement II : An AC circuit containing a pure capacitor or a pure inductor consumes high power due to its non-zero power factor.

In the light of above statements, choose the **correct** answer from the options given below :

Option :

- Both Statement I and Statement II are false
- Statement I is true but Statement II is false
- Both Statement I and Statement II are true
- Statement I is false but Statement II is true

Official Ans. by NTA (1)

Sol. For resonance, $\phi = 0$, hence both inductor & capacitor must be present. Also power factor is zero for pure inductor or pure capacitor hence both the component consume zero average power.

44. A vehicle of mass 200 kg is moving along a levelled curved road of radius 70 m with angular velocity of 0.2 rad/s. The centripetal force acting on the vehicle is :

Option :

- | | |
|-----------|------------|
| (1) 560 N | (2) 2800 N |
| (3) 14 N | (4) 2240 N |

Official Ans. by NTA (1)

Sol. $F_c = m\omega^2 r = 200 \times (0.2)^2 \times 70 = 560 \text{ N}$

45. To radiate EM signal of wavelength λ with high efficiency, the antennas should have a minimum size equal to :

Option :

- | | |
|-------------------------|-------------------------|
| (1) $\frac{\lambda}{2}$ | (2) $\frac{\lambda}{4}$ |
| (3) 2λ | (4) λ |

Official Ans. by NTA (2)

Sol. Minimum length of antenna should be $\frac{\lambda}{4}$.

46. Given below are two statements:

Statement I : Out of microwaves, infrared rays and ultraviolet rays, ultraviolet rays are the most effective for the emission of electrons from a metallic surface.

Statement II : Above the threshold frequency, the maximum kinetic energy of photoelectrons is inversely proportional to the frequency of the incident light.

In the light of above statements, choose the *correct* answer from the options given below

Option :

- (1) Statement I is true but Statement II is false
- (2) Both Statement I and Statement II are true
- (3) Statement I is false but Statement II is true
- (4) Both Statement I and Statement II are false

Official Ans. by NTA (1)

Sol. UV rays have maximum frequency hence are most effective for emission of electrons from a metallic surface.

$$KE_{\max.} = hf - hf_0$$

47. A 10 μC charge is divided into two parts and placed at 1 cm distance so that the repulsive force between them is maximum. The charges of the two parts are :

Option :

- (1) 9 μC , 1 μC
- (2) 5 μC , 5 μC
- (3) 7 μC , 3 μC
- (4) 8 μC , 2 μC

Official Ans. by NTA (2)

Sol. Divide $q = 10 \mu\text{C}$ into two parts x & $q - x$.

$$F = \frac{Kx(q-x)}{r^2}$$

For F to be maximum

$$\frac{dF}{dx} = \frac{K}{r^2} (q - 2x) = 0$$

$$x = \frac{q}{2}$$

48. In the equation $\left[X + \frac{a}{Y^2} \right] [Y - b] = RT$, X is pressure, Y is volume, R is universal gas constant and T is temperature. The physical quantity equivalent to the ratio $\frac{a}{b}$ is :

Option :

- (1) Energy
- (2) Impulse
- (3) Pressure gradient
- (4) Coefficient of viscosity

Official Ans. by NTA (1)

Sol. X and $\frac{a}{Y^2}$ have same dimensions

Y and b have same dimensions

$$\therefore [a] = [\text{ML}^5\text{T}^{-2}]$$

$$[b] = [\text{L}^3]$$

$$\frac{[a]}{[b]} = [\text{ML}^2\text{T}^{-2}] \text{ has dimensions of energy}$$

49. In a Young's double slits experiment, the ratio of amplitude of light coming from slits is 2:1. The ratio of the maximum to minimum intensity in the interference pattern is :

Option :

- (1) 9 : 4
- (2) 9 : 1
- (3) 2 : 1
- (4) 25 : 9

Official Ans. by NTA (2)

Sol. Given that $\frac{A_1}{A_2} = \frac{2}{1}$

$$\frac{I_{\max}}{I_{\min}} = \left(\frac{A_1 + A_2}{A_1 - A_2} \right)^2 = \frac{9}{1} = 9 : 1$$

50. The mean free path of molecules of a certain gas at STP is 1500d, where d is the diameter of the gas molecules. While maintaining the standard pressure, the mean free path of the molecules at 373K is approximately :

Option :

- (1) 1098d
- (2) 2049d
- (3) 750d
- (4) 1500d

Official Ans. by NTA (2)

Sol. Mean free path

$$\lambda = \frac{RT}{\sqrt{2}\pi d^2 N_A P}$$

$$\lambda \propto T$$

$$\frac{1500d}{\lambda} = \frac{273}{373}$$

$$\lambda = 2049d$$

SECTION-B

51. A bi convex lens of focal length 10 cm is cut in two identical parts along a plane perpendicular to the principal axis. The power of each lens after cut is _____ D.

Official Ans. by NTA (5)



Let power of each part is P_1 , then

$$P_1 + P_1 = P = \frac{1}{f}$$

$$2P_1 = \frac{1}{0.1} = 10$$

$$P_1 = 5D$$

52. An atom absorbs a photon of wavelength 500 nm and emits another photon of wavelength 600 nm. The net energy absorbed by the atom in this process is $n \times 10^{-4}$ eV. The value of n is _____.

[Assume the atom to be stationary during the absorption and emission process]

(Take $h = 6.6 \times 10^{-34}$ Js and $c = 3 \times 10^8$ m/s).

Official Ans. by NTA (4125)

Sol.

$$E = E_1 - E_2 = \frac{hc}{\lambda_1} - \frac{hc}{\lambda_2} = hc \left(\frac{1}{\lambda_1} - \frac{1}{\lambda_2} \right)$$

$$= 6.6 \times 10^{-34} \times 3 \times 10^8 \left(\frac{1}{500 \times 10^{-9}} - \frac{1}{600 \times 10^{-9}} \right)$$

$$= 6.6 \times 10^{-20} \text{ J}$$

$$= \frac{6.6 \times 10^{-20}}{1.6 \times 10^{-19}} \text{ eV} = 4.125 \times 10^{-1} \text{ eV}$$

$$= 4125 \times 10^{-4} \text{ eV}$$

53. Three point charges q , $-2q$ and $2q$ are placed on x -axis at a distance $x = 0$, $x = \frac{3}{4}R$ and $x = R$ respectively from origin as shown. If $q = 2 \times 10^{-6}$ C and $R = 2$ cm, the magnitude of net force experienced by the charge $-2q$ is _____ N.

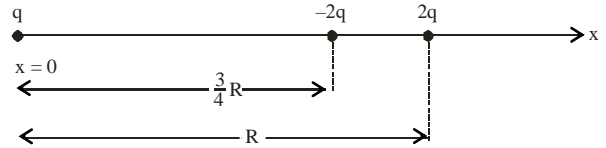

Official Ans. by NTA (5440)

Sol.

$$F_{BA} = \frac{Kq(2q)}{\left(\frac{3}{4}R\right)^2} = \frac{32Kq^2}{9R^2}$$

$$F_{BC} = \frac{K(2q)(2q)}{\left(\frac{R}{4}\right)^2} = \frac{64Kq^2}{R^2}$$

$$F_B = F_{BC} - F_{BA} = \frac{544Kq^2}{9R^2}$$

$$= \frac{544 \times 9 \times 10^9 \times (2 \times 10^{-6})^2}{9 \times (2 \times 10^{-2})^2} = 5440 \text{ N}$$

54. In the circuit shown, the energy stored in the capacitor is $n \mu\text{J}$. The value of n is _____.

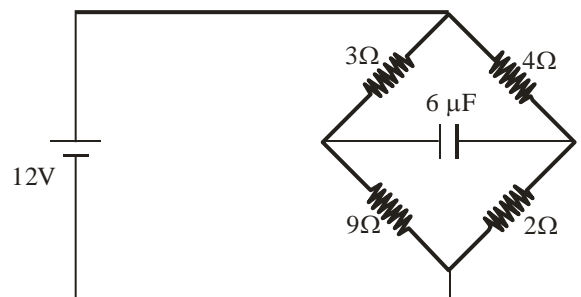

Official Ans. by NTA (75)

Sol. $I_1 = \frac{12}{3+9} = 1A$

$I_2 = \frac{12}{4+2} = 2A$

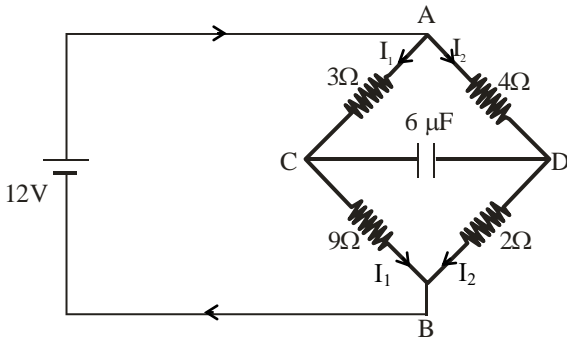

$V_A - V_C = 3I_1 = 3V \quad \dots(1)$

$V_A - V_D = 2 \times 4 = 8V \quad \dots(2)$

Subtracting eq. (1) from eq. (2)

$V_C - V_D = 5V \Rightarrow V = 5V$

$U = \frac{1}{2} CV^2 = \frac{1}{2} \times 6 \times 5^2 = 75 \mu J$

55. An insulated copper wire of 100 turns is wrapped around a wooden cylindrical core of the cross-sectional area 24 cm^2 . The two ends of the wire are connected to a resistor. The total resistance in the circuit is 12Ω . If an externally applied uniform magnetic field in the core along its axis changes from 1.5 T in one direction to 1.5 T in the opposite direction, the charge flowing through a point in the circuit during the change of magnetic field will be _____ mC.

Official Ans. by NTA (60)

Sol. $\Delta Q = -\frac{\Delta\phi}{R} = -\left(\frac{\phi_2 - \phi_1}{R}\right)$

$\phi_1 = NBA$

$\phi_2 = -NBA$

$\therefore \Delta Q = \frac{2NBA}{R} = \frac{2 \times 100 \times 1.5 \times 24 \times 10^{-4}}{12}$

$= 6 \times 10^{-2} \text{ C} = 60 \text{ mC}$

56. In an experiment with sonometer when a mass of 180 g is attached to the string, it vibrates with fundamental frequency of 30 Hz . When a mass m is attached, the string vibrates with fundamental frequency of 50 Hz . The value of m is _____ g.

Official Ans. by NTA (500)

Sol. $f = \frac{1}{2\ell} \sqrt{\frac{T}{\mu}} \quad (T : \text{Tension})$

$\frac{f_2}{f_1} = \sqrt{\frac{T_2}{T_1}}$

$\left(\frac{50}{30}\right)^2 = \frac{mg}{180g} \Rightarrow m = \frac{25}{9} \times 180 = 500 \text{ gram}$

57. A light rope is wound around a hollow cylinder of mass 5 kg and radius 70 cm . The rope is pulled with a force of 52.5 N . The angular acceleration of the cylinder will be _____ rad s^{-2} .

Official Ans. by NTA (15)

Sol. $\tau = I\alpha$

$\Rightarrow FR = mR^2\alpha$

$\alpha = \frac{F}{mR} = \frac{52.5}{5 \times 0.7} = 15 \text{ rad s}^{-2}$

58. A car accelerates from rest to $u \text{ m/s}$. The energy spent in this process is $E \text{ J}$. The energy required to accelerate the car from $u \text{ m/s}$ to $2u \text{ m/s}$ is $nE \text{ J}$. The value of n is _____.

Official Ans. by NTA (3)

Sol. $E_1 = \frac{1}{2} mu^2 - 0 = \frac{1}{2} mu^2 = E$

$E_2 = \frac{1}{2} m(2u)^2 - \frac{1}{2} mu^2 = \frac{3}{2} mu^2 = 3E$

59. Two plates A and B have thermal conductivities $84 \text{ Wm}^{-1}\text{K}^{-1}$ and $126 \text{ Wm}^{-1}\text{K}^{-1}$ respectively. They have same surface area and same thickness. They are placed in contact along their surfaces. If the temperatures of the outer surfaces of A and B are kept at 100°C and 0°C respectively, then the temperature of the surface of contact in steady state is _____ $^\circ\text{C}$.

Official Ans. by NTA (40)

Sol.

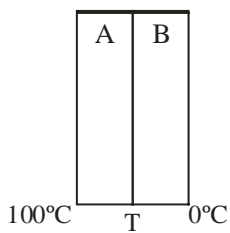

Let the temperature of contact surface is T, then

$$H_A = H_B$$

$$\frac{K_A A (T_A - T)}{L} = \frac{K_B A (T - T_B)}{L}$$

$$84(100 - T) = 126 (T - 0)$$

$$2(100 - T) = 3T$$

$$200 - 2T = 3T$$

$$T = 40^\circ\text{C}$$

60. A straight wire AB of mass 40 g and length 50 cm is suspended by a pair of flexible leads in uniform magnetic field of magnitude 0.40 T as shown in the figure. The magnitude of the current required in the wire to remove the tension in the supporting leads is _____ A. (Take $g = 10 \text{ ms}^{-2}$).

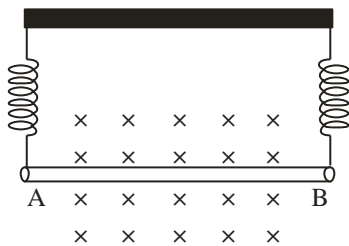

Official Ans. by NTA (2)

Sol. For equilibrium

$$Mg = I\ell B$$

$$I = \frac{mg}{\ell B} = \frac{40 \times 10^{-3} \times 10}{50 \times 10^{-2} \times 0.4} = 2\text{A}$$

SECTION-A

61. In the wet tests for detection of various cations by precipitation, Ba^{2+} cations are detected by obtaining precipitate of

- (1) $\text{Ba}(\text{ox})$: Barium oxalate
- (2) BaCO_3
- (3) $\text{Ba}(\text{OAc})_2$
- (4) BaSO_4

Official Ans. by NTA (2)

Sol. In wet testing, $(\text{NH}_4)_2\text{CO}_3$ is used as group reagent for 5th group cations (Ba^{2+} , Ca^{2+} , Sr^{2+})

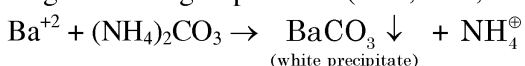

62. The naturally occurring amino acid that contains only one basic functional group in its chemical structure is

- (1) arginine
- (2) lysine
- (3) asparagine
- (4) histidine

Official Ans. by NTA (3)

Sol. Asparagine has only one basic functional group in its chemical structure.

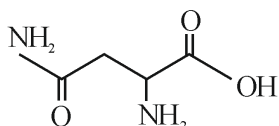

Others are basic amino acid with more than one basic functional group.

63. Given below are two statements related to Ellingham diagram:

Statement-I : Ellingham diagrams can be constructed for formation of oxides, sulfides and halides of metals.

Statement-II : It consists of plots of $\Delta_r H^0$ vs T for formation of oxides of elements.

In the light of the above statements, choose the most appropriate answer from the options given below:

- (1) Both Statement I and Statement II are incorrect
- (2) Statement I is incorrect but Statement II is correct
- (3) Both Statement I and Statement II are correct
- (4) Statement I is correct but Statement II is incorrect

Official Ans. by NTA (1)

Sol. Statement I is correct, Ellingham diagram can be constructed for formation of oxides, sulphides and halides of metals. (Ref: NCERT)

Statement II is incorrect because Ellingham diagram consists of $\Delta_r G^0$ vs T for formation of oxides of elements.

64. Given below are two statements, one is labelled as **Assertion A** and the other is labelled as **Reason R**.

Assertion A : The diameter of colloidal particles in solution should not be much smaller than wavelength of light to show Tyndall effect.

Reason R : The light scatters in all directions when the size of particles is large enough.

In the light of the above statements, choose the correct answer from the options given below:

- (1) A is true but R is false
- (2) A is false but R is true
- (3) Both A and R are correct and R is the correct explanation of A
- (4) Both A and R are correct but R is NOT the correct explanation of A

Official Ans. by NTA (3)

Sol. Tyndall effect is observed only when the following two conditions are satisfied

- (a) The diameter of the dispersed particle is not much smaller than the wave length of light used.
- (b) Refractive indices of dispersed phase and dispersion medium differ greatly in magnitude.

65. The total number of stereoisomers for the complex $[\text{Cr}(\text{ox})_2 \text{ClBr}]^{3-}$ (where ox = oxalate) is:

- (1) 2
- (2) 3
- (3) 1
- (4) 4

Official Ans. by NTA (2)

Sol. $[\text{Cr}(\text{Ox})_2\text{ClBr}]^{-3}$

- No. of isomers –

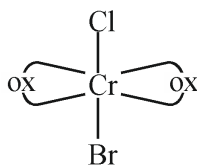

- This structure has plane of symmetry, So no optical isomerism will be shown.

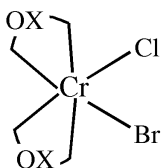

- This structure does not contain plane of symmetry, So two forms d as well as l will be shown.

66. Better method for preparation of BeF_2 , among the following is

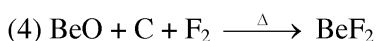
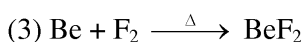
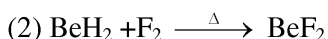

Official Ans. by NTA (1)

Sol. As per NCERT (s block), the better method of preparation of BeF_2 is heating $(\text{NH}_4)_2\text{BeF}_4$

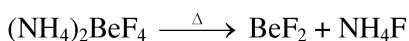

67. Given below are two statements, one is labelled as **Assertion A** and the other is labelled as **Reason R**.

Assertion A : Isotopes of hydrogen have almost same chemical properties, but difference in their rates of reaction.

Reason R : Isotopes of hydrogen have different enthalpy of bond dissociation.

In the light of the above statements, choose the most appropriate answer from the options given below:

- Both A and R are correct but R is NOT the correct explanation of A
- Both A and R are correct and R is the correct explanation of A
- A is not correct but R is correct
- A is correct but R is not correct

Official Ans. by NTA (2)

Sol. Source NCERT

Since the isotopes have the same electronic configuration, they have almost same chemical properties. The only difference is in their rates of reactions, mainly due to their different enthalpy of bond dissociation.

68. Given below are two statements:

Statement I: Tropolone is an aromatic compound and has 8π electrons.

Statement II: π electrons of $>\text{C}=\text{O}$ group in tropolone is involved in aromaticity.

In the light of the above statements, choose the correct answer from the options given below:

- Both Statement I and Statement II are true
- Statement I is true but Statement II is false
- Statement I is false but Statement II is true
- Both Statement I and Statement II are false

Official Ans. by NTA (2)

Sol.

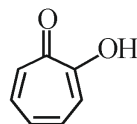

Tropolone is an aromatic compound and has 8π electrons ($6\pi e^-$ are endocyclic and $2\pi e^-$ are exocyclic) and π electrons of $>\text{C}=\text{O}$ group in tropolone is not involved in aromaticity.

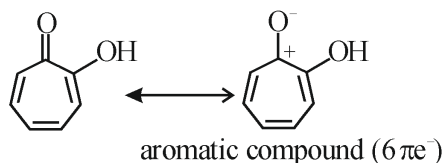

69. Compound A from the following reaction sequence is:

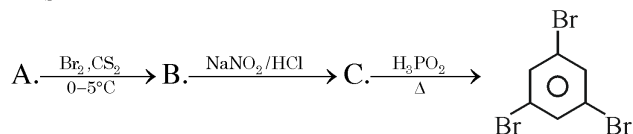

- Benzoic Acid
- Phenol
- Salicylic Acid
- Aniline

Official Ans. by NTA (4)

Sol.

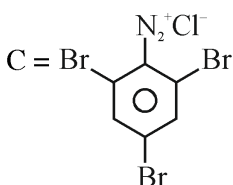
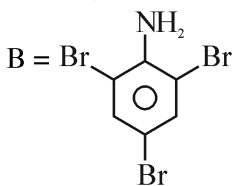
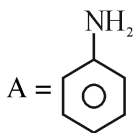

70. The major product for the following reaction is:

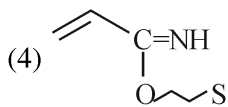
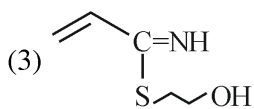
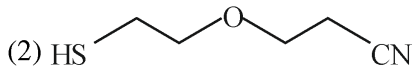
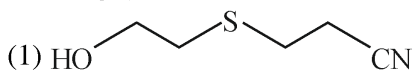
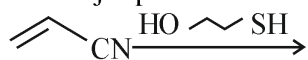

Official Ans. by NTA (1)

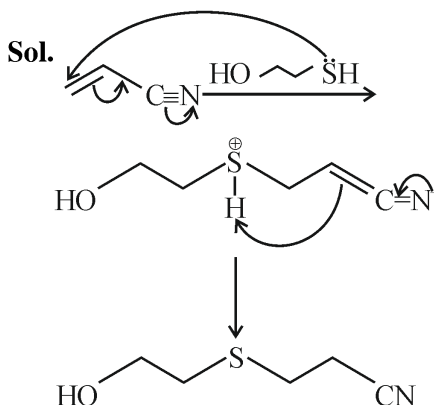

71. Which of the following are the Green house gases?

- A. Water vapour
- B. Ozone
- C. I₂
- D. Molecular hydrogen

Choose the most appropriate answer from the options given

- (1) B and C only
- (2) C and D only
- (3) A and D only
- (4) A and B only

Official Ans. by NTA (4)

Sol. Green house gases are CO₂, CH₄, water vapour, nitrous oxide, CFC_s and ozone.

72. Match List I with List II

| | LIST I | | LIST II |
|----|--|------|---------------------------------------|
| A. | Weak intermolecular forces of attraction | I. | Hexamethylenedia mine + adipic acid |
| B. | Hydrogen bonding | II. | AlEt ₃ + TiCl ₄ |
| C. | Heavily branched polymer | III. | 2-chloro-1, 3-butadiene |
| D. | High density polymer | IV. | Phenol + formaldehyde |

Choose the correct answer from the options given below:

- (1) A-II, B-IV, C-I, D-III
- (2) A-III, B-I, C-IV, D-II
- (3) A-IV, B-I, C-III, D-II
- (4) A-IV, B-II, C-III, D-I

Official Ans. by NTA (2)

Sol.

- Hexamethylenediamine on reaction with adipic acid forms Nylon 6, 6 which shows H-bonding due to presence of amide group.
- AlEt₃ + TiCl₄ is Ziegler-Natta catalyst used to prepare high density polyethylene.
- 2-chloro-1, 3-butadiene (chloroprene) is monomer of neoprene which is a rubber (an elastomer)
- Phenol – formaldehyde forms Bakelite which is heavily branched (cross-linked) polymer

73. Given below are two statements :

Statement I: SO₂ and H₂O both possess V-shaped structure.

Statement II: The bond angle of SO₂ is less than that of H₂O.

In the light of the above statements, choose the most appropriate answer from the options given below:

- (1) Both Statement I and Statement II are correct
- (2) Statement I is correct but Statement II is incorrect
- (3) Both Statement I and Statement II are incorrect
- (4) Statement I is incorrect but Statement II is correct

Official Ans. by NTA (2)

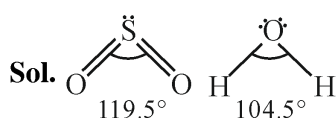

Both are bent in shape.

Bond angle of SO₂ (sp²) is greater than that of H₂O (sp³) due to higher repulsion of multiple bonds.

74. The correct group of halide ions which can be oxidised by oxygen in acidic medium is

- (1) Br⁻ only
- (2) Cl⁻, Br⁻ and I⁻ only
- (3) Br⁻ and I⁻ only
- (4) I⁻ only

Official Ans. by NTA (4)

Sol. Only I⁻ among halides can be oxidised to Iodine by oxygen in acidic medium

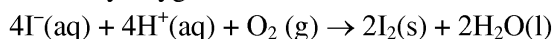

75. What happens when methane undergoes combustion in systems A and B respectively?

| | |
|---------------------|-------------------------|
| Adiabatic system | Diathermic container |
| System A | System B |

(1)

| System A | System B |
|-------------------|--------------------------|
| Temperature rises | Temperature remains same |

(2)

| System A | System B |
|-------------------|-------------------|
| Temperature falls | Temperature rises |

(3)

| System A | System B |
|-------------------|--------------------------|
| Temperature falls | Temperature remains same |

(4)

| System A | System B |
|--------------------------|-------------------|
| Temperature remains same | Temperature rises |

Official Ans. by NTA (1)

Sol. Adiabatic boundary does not allow heat exchange thus heat generated in container can't escape out thereby increasing the temperature.

In case of Diathermic container, heat flow can occur to maintain the constant temperature.

76. Given below are two statements, one is labelled as **Assertion A** and the other is labelled as **Reason R**.
Assertion A : Order of acidic nature of the following compounds is A > B > C.

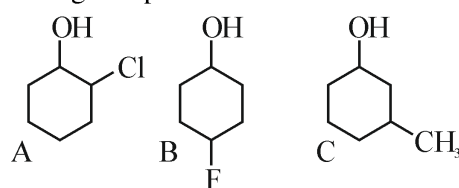

Reason R : Fluoro is a stronger electron withdrawing group than Chloro group.

In the light of the above statements, choose the correct answer from the options given below:

- (1) A is false but R is true
- (2) Both A and R are correct and R is the correct explanation of A
- (3) Both A and R are correct but R is NOT the correct explanation of A
- (4) A is true but R is false

Official Ans. by NTA (3)

Sol. Acidic strength $\propto -I$ effect

$$\propto \frac{1}{+I} \text{ effect}$$

F, Cl exerts -I effect, Methyl exerts +I effect, C is least acidic.

Among A and B; since inductive effect is distance dependent, Extent of -I effect is higher in A followed by B even though F is stronger electron withdrawing group than Cl. Thus, A is more acidic than B.

77. Identify the correct order of standard enthalpy of formation of sodium halides.

- (1) NaI < NaBr < NaCl < NaF
- (2) NaF < NaCl < NaBr < NaI
- (3) NaCl < NaF < NaBr < NaI
- (4) NaI < NaBr < NaF < NaCl

Official Ans. by NTA (1)

Sol. For a given metal $\Delta_f H^0$ always becomes less negative from fluoride to iodide.

78. Match List I with List II

1 - Bromopropane is reacted with reagents in List I to give product in List II

| | LIST I - Reagent | | LIST II - Product |
|----|-----------------------|------|-------------------|
| A. | KOH (alc) | I. | Nitrile |
| B. | KCN (alc) | II. | Ester |
| C. | AgNO ₂ | III. | Alkene |
| D. | H ₃ CCOOAg | IV. | Nitroalkane |

(1) A-IV, B-III, C-II, D-I

(2) A-III, B-I, C-IV, D-II

(3) A-I, B-II, C-III, D-IV

(4) A-I, B-III, C-IV, D-II

Official Ans. by NTA (2)

Sol.

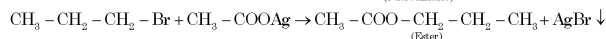
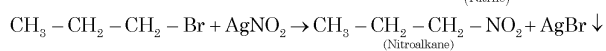
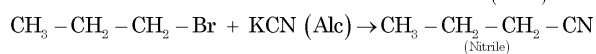

79. The covalency and oxidation state respectively of boron in $[\text{BF}_4]^-$, are

(1) 4 and 3

(2) 4 and 4

(3) 3 and 4

(4) 3 and 5

Official Ans. by NTA (1)

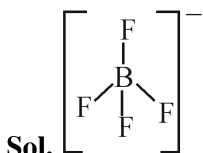

Number of covalent bond formed by Boron is 4

Oxidation number of fluorine is -1,

Oxidation number of B + 4 × (-1) = -1,

Thus, Oxidation number of B = +3

80. Which of the following complexes will exhibit maximum attraction to an applied magnetic field?

(1) $[\text{Zn}(\text{H}_2\text{O})_6]^{2+}$

(2) $[\text{Co}(\text{H}_2\text{O})_6]^{2+}$

(3) $[\text{Co}(\text{en})_3]^{3+}$

(4) $[\text{Ni}(\text{H}_2\text{O})_6]^{2+}$

Official Ans. by NTA (2)

Sol. Complex with maximum number of unpaired electron will exhibit maximum attraction to an applied magnetic field

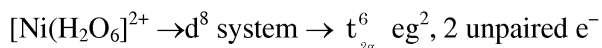
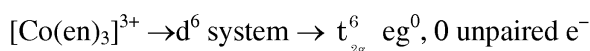
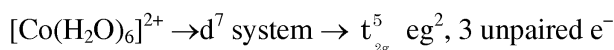
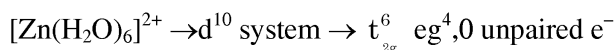
**SECTION-B**

81. 0.400 g of an organic compound (X) gave 0.376 g of AgBr in Carius method for estimation of bromine. % of bromine in the compound (X) is _____.

(Given: Molar mass AgBr = 188 g mol⁻¹ Br = 80 g mol⁻¹)

Official Ans. by NTA (40)

$$\text{Sol. mole of AgBr} = \frac{0.376}{188}$$

$$\text{mole of Br}^- = \text{mole of AgBr} = \frac{0.376}{188}$$

$$\text{mass of Br}^- = \frac{0.376}{188} \times 80$$

$$\% \text{ of Br}^- = \frac{0.376 \times 80}{188 \times 0.4} \times 100 = 40\%$$

82. 1g of a carbonate (M_2CO_3) on treatment with excess HCl produces 0.01 mol of CO₂. The molar mass of M_2CO_3 is _____ g mol⁻¹. (Nearest integer)

Official Ans. by NTA (100)

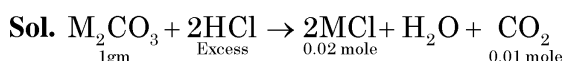

From principle of atomic conservation of carbon atom,

$$\text{Mole of M}_2\text{CO}_3 \times 1 = \text{Mole of CO}_2 \times 1$$

$$\frac{1\text{gm}}{\text{molar mass of M}_2\text{CO}_3} = 0.01 \times 1$$

∴ Molar mass of $\text{M}_2\text{CO}_3 = 100 \text{ gm/mole}$

83. See the following chemical reaction:

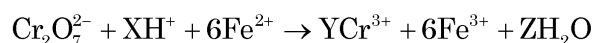

The sum of X, Y and Z is _____.

Official Ans. by NTA (23)

Sol.

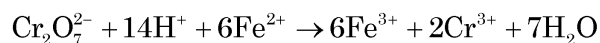

$$x = 14$$

$$y = 2$$

$$z = 7$$

$$\text{Hence } (x + y + z) = 14 + 2 + 7 = 23$$

84. If the formula of Borax is $\text{Na}_2\text{B}_4\text{O}_x(\text{OH})_y \cdot z\text{H}_2\text{O}$, then $x + y + z =$ _____.

Official Ans. by NTA (17)

Sol. Formula of borax is $\text{Na}_2\text{B}_4\text{O}_5(\text{OH})_4 \cdot 8\text{H}_2\text{O}$

85. At 298 K, the standard reduction potential for Cu^{2+}/Cu electrode is 0.34 V.

Given : $K_{\text{sp}} \text{Cu}(\text{OH})_2 = 1 \times 10^{-20}$

$$\text{Take } \frac{2.303RT}{F} = 0.059\text{V}$$

The reduction potential at $\text{pH} = 14$ for the above couple is $(-x) \times 10^{-2}$ V. The value of x is _____.

Official Ans. by NTA (25)

Sol. $\text{Cu}(\text{OH})_2(\text{s}) \rightleftharpoons \text{Cu}^{2+}(\text{aq}) + 2\text{OH}^{-}(\text{aq})$

$$K_{\text{sp}} = [\text{Cu}^{2+}] [\text{OH}^{-}]^2$$

$$\text{pH} = 14 ; \text{pOH} = 0 ; [\text{OH}^{-}] = 1\text{M}$$

$$\therefore [\text{Cu}^{2+}] = \frac{K_{\text{sp}}}{[\text{OH}^{-}]^2} = 10^{-20}\text{M}$$

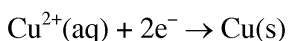

$$E = E^{\circ} - \frac{0.059}{2} \log_{10} \frac{1}{[\text{Cu}^{2+}]}$$

$$= 0.34 - \frac{0.059}{2} \log_{10} \frac{1}{10^{-20}}$$

$$= -0.25 = -25 \times 10^{-2}$$

86. 20 mL of 0.1 M NaOH is added to 50 mL of 0.1 M acetic acid solution. The pH of the resulting solution is _____ $\times 10^{-2}$ (Nearest integer)

Given : $\text{pK}_a(\text{CH}_3\text{COOH}) = 4.76$

$$\log 2 = 0.30$$

$$\log 3 = 0.48$$

Official Ans. by NTA (448)

Sol. $\text{CH}_3\text{COOH} + \text{NaOH} \rightarrow \text{CH}_3\text{COONa} + \text{H}_2\text{O}$

| | | | | |
|-----------|-------|-------|---------|---------|
| Initially | 5mmol | 2mmol | 0 | 0 |
| after Rxn | 3mmol | 0 | 2 mmole | 2 mmole |

$$\text{pH} = \text{pK}_a + \log_{10} \frac{[\text{salt}]}{[\text{acid}]}$$

$$\text{pH} = 4.76 + \log_{10} \frac{2}{3}$$

$$\text{pH} = 4.58 = 458 \times 10^{-2}$$

87. $\text{A}(\text{g}) \rightarrow 2\text{B}(\text{g}) + \text{C}(\text{g})$ is a first order reaction. The initial pressure of the system was found to be 800 mm Hg which increased to 1600 mm Hg after 10 min. The total pressure of the system after 30 min will be _____ mm Hg. (Nearest integer)

Official Ans. by NTA (2200)

Sol. $t_{\frac{1}{2}} = 10$ minutes

$$(P_A)_{30\text{min}} = (P_A)_0 \left(\frac{1}{2}\right)^{30/10}$$

$$(P_A)_{30\text{min}} = 100 \text{ mm Hg}$$

| | | | |
|-----------|---|--------|-------|
| | $\text{A}(\text{g}) \rightarrow 2\text{B}(\text{g}) + \text{C}(\text{g})$ | | |
| at t = 0 | 800mm | 0 | 0 |
| at t = 30 | 100mm | 1400mm | 700mm |

Total pressure after 30 minutes = 2200 mm Hg

88. The orbital angular momentum of an electron in 3s orbital is $\frac{x\hbar}{2\pi}$. The value of x is

Official Ans. by NTA (0)

Sol. Orbital angular momentum = $\sqrt{l(l+1)} \frac{\hbar}{2\pi}$

Value of l for s = 0

89. Sodium metal crystallizes in a body centred cubic lattice with unit cell edge length of 4 Å. The radius of sodium atom is _____ $\times 10^{-1}$ Å (Nearest integer)

Official Ans. by NTA (17)

Sol. $\sqrt{3}a = 4r$

$$\sqrt{3} \times 4 = 4r$$

$$r = 1.732\text{Å}$$

$$= 17.32 \times 10^{-1}$$

90. Sea water contains 29.25% NaCl and 19% MgCl₂ by weight of solution. The normal boiling point of the sea water is _____ °C (Nearest integer)

Assume 100% ionization for both NaCl and MgCl₂

Given : $K_b(\text{H}_2\text{O}) = 0.52 \text{ K kg mol}^{-1}$

Molar mass of NaCl and MgCl₂ is 58.5 and 95 g mol⁻¹ respectively.

Official Ans. by NTA (116)

Sol.

Amount of solvent = 100 – (29.25 + 19) = 51.75g

$$\Delta T_b = \left[\frac{2 \times 29.25 \times 1000}{58.5 \times 51.75} + \frac{3 \times 19 \times 1000}{95 \times 51.75} \right] \times 0.52$$

$$\Delta T_b = 16.075$$

$$\Delta T_b = (T_b)_{\text{solution}} - (T_b)_{\text{solvent}}$$

$$(T_b)_{\text{solution}} = 100 + 16.07$$

$$= 116.07^\circ\text{C}$$