

Physics

SECTION - A

1. For three low density gases A, B, C pressure versus temperature graphs are plotted while keeping them at constant volume, as shown in the figure.

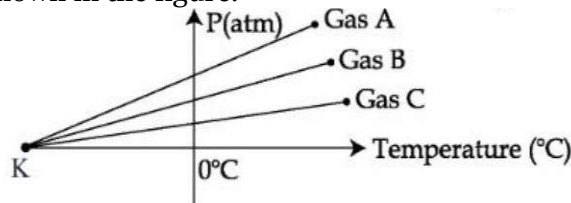

The temperature corresponding to the point 'K' is :

- (1) -273°C (2) -100°C (3) -40°C (4) -373°C

Sol. (1)

From ideal gas equation

$$PV = nRT$$

\therefore volume is constant

$$P \propto T$$

It is clear from graph that for all the gases lines of graphs meet at same value.

At x-axis (temperature axis) P is zero but temperature is negative and it will be equal to 0 K or -273°C

2. Given below are two statements : One is labelled as Assertion A and the other is labelled as Reason R.
Assertion A : For measuring the potential difference across a resistance of 600Ω , the voltmeter with resistance 1000Ω will be preferred over voltmeter with resistance 4000Ω .

Reason R : Voltmeter with higher resistance will draw smaller current than voltmeter with lower resistance.

In the light of the above statements, choose the most appropriate answer from the options given below.

- (1) Both A and R are correct and R is the correct explanation of A
(2) Both A and R are correct but R is not the correct explanation of A
(3) A is not correct but R is correct
(4) A is correct but R is not correct

Sol. (3)

To measure the potential difference between two point, voltmeter is used. But this voltmeter should be with higher resistance so that it cannot draw any current.

Now to measure the potential difference across 600Ω voltmeter of 4000Ω is much better than 1000Ω voltmeter.

3. Figures (a), (b), (c) and (d) show variation of force with time.

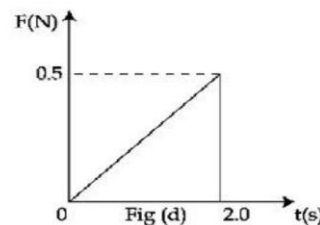
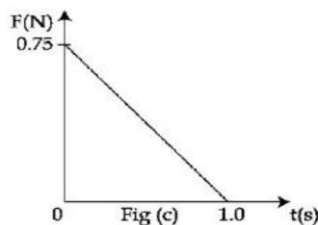
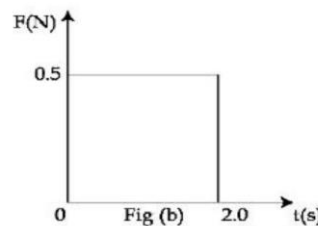
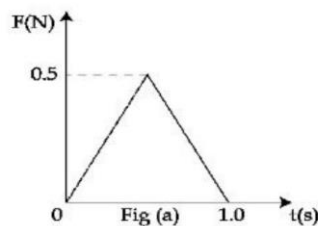

The impulse is highest in figure.

- (1) Fig (c) (2) Fig (b) (3) Fig (d) (4) Fig (a)

Sol. (2)

As we know that impulse is given by

$$I = \Delta P = F \times \Delta t$$

or $I = \text{Area of } f\text{-}t \text{ graph}$

For fig (a) $\rightarrow I = \frac{1}{2} \times \text{base} \times \text{height}$

$$= \frac{1}{2} \times 0.5 \times 1 = 0.25 \text{ N-sec.}$$

For fig (b) $I = \text{length} \times \text{width}$

$$= 2 \times 0.5 = 1 \text{ N-sec}$$

For fig (c) $I = \frac{1}{2} \times \text{base} \times \text{height}$

$$= \frac{1}{2} \times 1 \times 0.75 = 0.375 \text{ N-sec.}$$

For fig (d) $I = \frac{1}{2} \times \text{base} \times \text{height}$

$$= \frac{1}{2} \times 2 \times 0.5 = 0.5 \text{ N-sec.}$$

Impulse is highest for that figure, whose area under F-t is maximum and i.e. figure(b)

Option (2) is correct.

4. An electron of a hydrogen like atom, having $Z = 4$, jumps from 4th energy state to 2nd energy state. The energy released in this process, will be :

(Given $R_{ch} = 13.6\text{eV}$)

Where $R = \text{Rydberg constant}$

$c = \text{Speed of light in vacuum}$

$h = \text{Planck's constant}$

(1) 40.8eV

(2) 3.4eV

(3) 10.5eV

(4) 13.6eV

Sol. (1)

$$\Delta E = 13.6Z^2 \left(\frac{1}{n_1^2} - \frac{1}{n_2^2} \right)$$

$Z = 4$ (hydrogen like atom)

$n_1 = 2, n_2 = 4$

$$\Delta E = 13.6(4)^2 \left(\frac{1}{4} - \frac{1}{16} \right)$$

$$= 13.6 \times \left(\frac{16-4}{64} \right) \times 16$$

$$\Delta E = 13.6 \times \frac{12}{64} \times 16$$

$$\boxed{\Delta E = 40.8\text{eV}}$$

5. The ratio of average electric energy density and total average energy density of electromagnetic wave is :

(1) 3

(2) $\frac{1}{2}$

(3) 1

(4) 2

Sol. (2)

Ratio of average electric energy density and total Avg energy density.

$$\text{Avg electric energy density} = \frac{1}{4} \epsilon_0 E_0^2$$

$$\text{Total Avg energy density} = \frac{1}{2} \epsilon_0 E_0^2$$

$$\Rightarrow \frac{\frac{1}{4} \epsilon_0 E_0^2}{\frac{1}{2} \epsilon_0 E_0^2} = \frac{2}{4} = \frac{1}{2}$$

6. Two objects A and B are placed at 15 cm and 25 cm from the pole in front of a concave mirror having radius of curvature 40 cm. The distance between images formed by the mirror is _____.

- (1) 100 cm (2) 60 cm (3) 160 cm (4) 40 cm

Sol. (3)

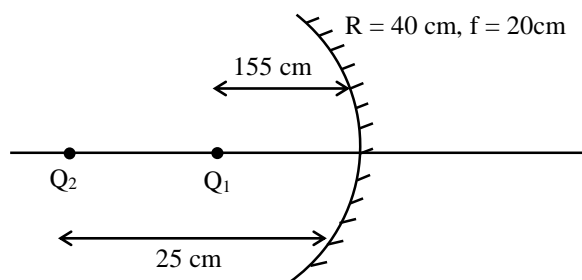

Using Mirror formula

$$\frac{1}{v} + \frac{1}{u} = \frac{1}{f}$$

$$\frac{1}{v} = \frac{1}{f} - \frac{1}{u}$$

$$\boxed{v = \frac{4f}{u - f}}$$

For object A (O_1) $u_1 = -15$ cm, $f = -20$ cm, $V_1 = ?$

$$v_1 = \frac{u_1 f}{u_1 - f} = \frac{(-15)(-20)}{(-15) - (-20)} = \frac{+300}{5}$$

$$\boxed{v_1 = +60 \text{ cm}}$$

For object B (O_2) $u_2 = -25$ cm, $f = -20$ cm $v_2 = ?$

$$v_2 = \frac{u_2 f}{u_2 - f} = \frac{(-25)(-20)}{(-25) - (-20)} = \frac{500}{-5}$$

$$\boxed{v_2 = -100 \text{ cm}}$$

Hence, the distance between images formed by the mirror is

$$\boxed{d = 160 \text{ cm}}$$

7. Equivalent resistance between the adjacent corners of a regular n-sided polygon of uniform wire of resistance R would be:

- (1) $\frac{n^2 R}{n-1}$ (2) $\frac{(n-1)R}{n}$ (3) $\frac{(n-1)R}{n^2}$ (4) $\frac{(n-1)R}{(2n-1)}$

Sol. (3)

When, a uniform wire of resistance R is shaped into a regular n-sided polygon, the resistance of each side will be

$$\frac{R}{n} = R_1$$

Let R_1 & R_2 be the resistance between adjacent corners of a regular polygon

$$\therefore \text{The resistance of } (n-1) \text{ side, } R_2 = \frac{(n-1)R}{n}$$

Since two parts are parallel, therefore R_{eq}

$$R_{eq} = \frac{R_1 R_2}{R_1 + R_2} = \frac{\left(\frac{R}{n}\right)\left(\frac{n-1}{n}\right)R}{\left(\frac{R}{n}\right) + \left(\frac{n-1}{n}\right)R}$$

$$R_{eq} = \frac{(n-1)R^2}{n^2} \times \frac{n}{R + nR - R}$$

$$\boxed{R_{eq} = \frac{(n-1)R}{n^2}}$$

8. A Carnot engine operating between two reservoirs has efficiency $\frac{1}{3}$. When the temperature of cold reservoir raised by x , its efficiency decreases to $\frac{1}{6}$. The value of x , if the temperature of hot reservoir is 99°C , will be :

- (1) 66 K (2) 62 K (3) 33 K (4) 16.5 K

Sol. (2)

Given $\eta = \frac{1}{3}$

When $T_2 \rightarrow (T_2 + x)$ i.e., temp. of cold reservoir

$$\eta' = \frac{1}{6}$$

Temp. of hot reservoir (T_1) = 99°C
 $= 99 + 273 = 372^\circ\text{K}$

As we know,

$$\eta = 1 - \frac{T_2}{T_1} = \frac{1}{3} \quad \dots(1)$$

$$\eta' = 1 - \frac{(T_2 - x)}{T_1} = \frac{1}{6} \quad \dots(2)$$

$$\eta' = \frac{T_1 - (T_2 + x)}{T_1} = \frac{1}{6}$$

From equation (1)

$$\frac{1}{3} = 1 - \frac{T_2}{372}$$

$$\frac{1}{3} = \frac{372 - T_2}{372}$$

$$372 - \frac{372}{3} = T_2$$

$$T_2 = 248\text{K}$$

By putting the value of T_2 in equation (2)

$$\frac{T_1 - (T_2 - x)}{T_1} = \frac{1}{6}$$

$$\frac{372 - (248 + x)}{372} = \frac{1}{6}$$

$$372 - 248 - x = \frac{372}{6}$$

$$124 - x = 62$$

$$124 - 62 = x$$

$$\boxed{x = 62\text{K}}$$

9. Given below are two statements: One is labelled as Assertion A and the other is labelled as Reason R.
 Assertion A: Two metallic spheres are charged to the same potential. One of them is hollow and another is solid, and both have the same radii. Solid sphere will have lower charge than the hollow one.

Reason R: Capacitance of metallic spheres depend on the radii of spheres.

In the light of the above statements, choose the correct answer from the options given below.

- (1) Both A and R are true and R is the correct explanation of A
 (2) A is true but R is false
 (3) A is false but R is true
 (4) Both A and R are true but R is not the correct explanation of A

Sol. (3)

As we know, capacitance of spherical conductor

$$C = 4\pi\epsilon_0 R$$

So, capacitance does not depend on its charge, it depends only on the radius of the conductor (R).

Therefore, assertion is false, R is true.

10. If the velocity of light c , universal gravitational constant G and Planck's constant h are chosen as fundamental quantities. The dimensions of mass in the new system is :

- (1) $[h^{1/2}c^{-1/2}G^1]$ (2) $[h^{-1/2}c^{1/2}G^{1/2}]$ (3) $[h^{1/2}c^{1/2}G^{-1/2}]$ (4) $[h^1c^1G^{-1}]$

Sol. (3)

$$[M] = [G]^x [h]^y [c]^z$$

$$[M] = [M^{-1}L^3T^{-2}]^x [ML^2T^{-1}]^y [LT^{-1}]^z$$

$$[M^2L^0T^0] = [M^{-x+y}][L^{3x+2y+z}][T^{-2x-y-z}]$$

$$y - x = 1 \quad \dots(1)$$

$$3x + 2y + z = 0 \quad \dots(2)$$

$$-2x - y - z = 0 \quad \dots(3)$$

$$\text{On solving, } x = -\frac{1}{2}, y = \frac{1}{2}, z = \frac{1}{2}$$

$$\text{So } m = \sqrt{\frac{hc}{G}}$$

- 11.** Choose the correct statement about Zener diode :
- (1) It works as a voltage regulator in forward bias and behaves like simple pn junction diode in reverse bias.
 (2) It works as a voltage regulator only in forward bias.
 (3) It works as a voltage regulator in both forward and reverse bias.
 (4) It works as a voltage regulator in reverse bias and behaves like simple pn junction diode in forward bias.

Sol. (4)
 Zener diode act as a voltage regulator & it is used in reverse bias.
 Similarly it behaves as a pn junction diode in forward bias.

- 12.** The Young's modulus of a steel wire of length 6 m and cross-sectional area 3 mm^2 , is $2 \times 10^{11} \text{ N/m}^2$. The wire is suspended from its support on a given planet. A block of mass 4 kg is attached to the free end of the wire. The acceleration due to gravity on the planet is $\frac{1}{4}$ of its value on the earth. The elongation of wire is (Take g on the earth = 10 m/s^2) :

- (1) 0.1 cm (2) 0.1 mm (3) 1 cm (4) 1 mm

Sol. (2)
 As we know,

$$Y = \frac{\text{stress}}{\text{strain}}$$

$$Y = \frac{FL}{A\Delta L}$$

Given : $Y = 2 \times 10^{11} \text{ N/m}^2$

$$L = 6 \text{ m} \qquad g_p = \frac{g}{4}$$

$$A = 3 \text{ mm}^2$$

$$M = 4 \text{ kg}$$

$$F = mg_p$$

$$F = 4 \times \frac{10}{4} = 10 \text{ N}$$

$$\text{Hence } 2 \times 10^{11} = \frac{10 \times 6}{3 \times 10^{-6} \times \Delta L}$$

$$\boxed{\Delta L = 0.1 \text{ mm}}$$

- 13.** In an amplitude modulation, a modulating signal having amplitude of X V is superimposed with a carrier signal of amplitude Y V in first case. Then, in second case, the same modulating signal is superimposed with different carrier signal of amplitude 2Y V. The ratio of modulation index in the two cases respectively will be :

- (1) 2: 1 (2) 1: 2 (3) 4: 1 (4) 1: 1

Sol. (1)
 μ = ratio of modulation index

$$A_m = X, A_c = y$$

$$A_m = X, A_c = 2y$$

$$\mu_1 = \frac{A_m}{A_c} = \frac{x}{y} \qquad \dots(1)$$

$$\mu_2 = \frac{A_m}{A_c} = \frac{x}{2y} \qquad \dots(2)$$

$$\text{Hence } \frac{\text{eq}^n(1)}{\text{eq}^n(2)} = \frac{\mu_1}{\mu_2} = \frac{x/y}{x/2y} = \frac{2y}{y}$$

$$\boxed{\frac{\mu_1}{\mu_2} = \frac{2}{1}}$$

14. The threshold frequency of a metal is f_0 . When the light of frequency $2f_0$ is incident on the metal plate, the maximum velocity of photoelectrons is v_1 . When the frequency of incident radiation is increased to $5f_0$, the maximum velocity of photoelectrons emitted is v_2 . The ratio of v_1 to v_2 is:

(1) $\frac{v_1}{v_2} = \frac{1}{8}$ (2) $\frac{v_1}{v_2} = \frac{1}{4}$ (3) $\frac{v_1}{v_2} = \frac{1}{16}$ (4) $\frac{v_1}{v_2} = \frac{1}{2}$

Sol. (4)

Using photoelectric equation

$$hf - hf_0 = eV_0$$

As per question

$$h(2f_0) - h(f_0) = eV_1$$

$$h(2f_0 - f_0) = eV_1$$

$$hf_0 = eV_1 \quad \dots(1)$$

$$h(5f_0) - hf_0 = eV_2$$

$$h(5f_0 - f_0) = eV_2$$

$$4hf_0 = eV_2 \quad \dots(2)$$

$$\text{Equation } \frac{2}{1} \Rightarrow \frac{4hf_0}{hf_0} = \frac{eV_2}{eV_1}$$

$$\boxed{\frac{V_2}{V_1} = 4}$$

As we know

$$KE_{\max} = eV = \frac{1}{2}mv_{\max}^2$$

$$v_{\max} \propto \sqrt{V}$$

$$\therefore \frac{v_2}{v_1} = \sqrt{\frac{V_2}{V_1}} = \sqrt{4} = 2$$

$$\boxed{\frac{v_1}{v_2} = \frac{1}{2}}$$

15. A coil is placed in magnetic field such that plane of coil is perpendicular to the direction of magnetic field. The magnetic flux through a coil can be changed:

- A. By changing the magnitude of the magnetic field within the coil.
- B. By changing the area of coil within the magnetic field.
- C. By changing the angle between the direction of magnetic field and the plane of the coil.
- D. By reversing the magnetic field direction abruptly without changing its magnitude.

Choose the most appropriate answer from the options given below :

- (1) A and B only (2) A, B and D only (3) A, B and C only (4) A and C only

Sol. (3)

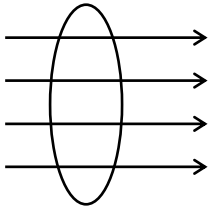

$$\phi = BA \cos \theta$$

This show

- (1) by changing B
- (2) by changing A
- (3) Angle (θ) between B and plane of coil.

16. Choose the correct length (L) versus square of time period (T^2) graph for a simple pendulum executing simple harmonic motion.

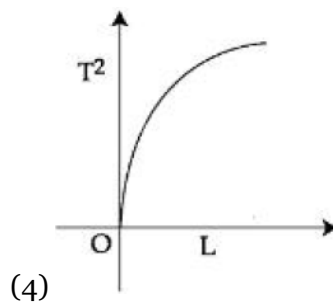
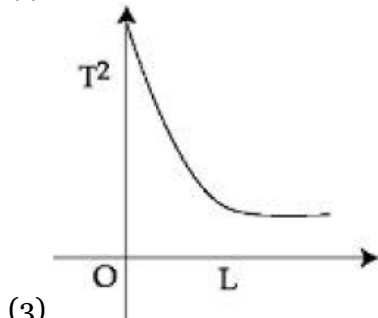
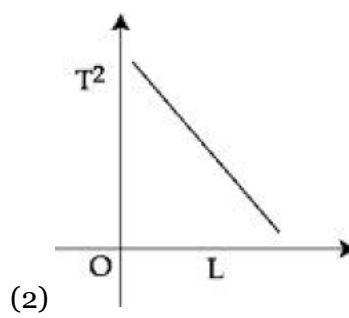
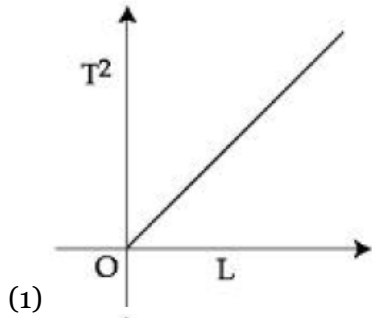

Sol. (1)

As we know, time period of simple pendulum is

$$T = 2\pi \sqrt{\frac{L}{g}}$$

or $T^2 = \frac{4\pi^2}{g} L \Rightarrow T^2 \propto L$

Thus the graph between T^2 & L is a straight line

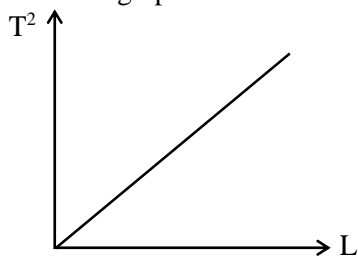

17. As shown in the figure, a long straight conductor with semicircular arc of radius $\frac{\pi}{10}$ m is carrying current $I = 3$ A. The magnitude of the magnetic field. at the center O of the arc is : (The permeability of the vacuum = $4\pi \times 10^{-7} \text{NA}^{-2}$)

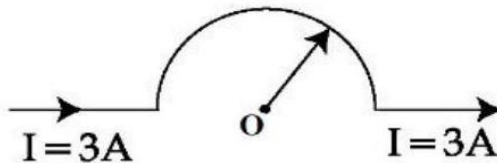

- Sol. (1) $1 \mu\text{T}$ (2) $3 \mu\text{T}$ (3) $4 \mu\text{T}$ (4) $6 \mu\text{T}$

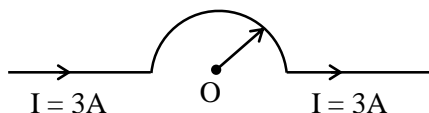

Given: $R = \frac{\pi}{10}$ m, $I = 3$ A, $\mu_0 = 4\pi \times 10^{-7} \text{N/A}^2$

Magnetic field due to semi-circular arc is

$$B = \frac{\mu_0 I}{4R}$$

$$B = \frac{\mu_0 \times 3}{4 \times \left(\frac{\pi}{10}\right)} = \frac{4\pi \times 10^{-7} \times 3}{4 \times \frac{\pi}{10}}$$

$$\boxed{B = 3 \mu\text{T}}$$

18. As shown in the figure a block of mass 10 kg lying on a horizontal surface is pulled by a force F acting at an angle 30° , with horizontal. For $\mu_s = 0.25$, the block will just start to move for the value of F : [Given $g = 10 \text{ms}^{-2}$]

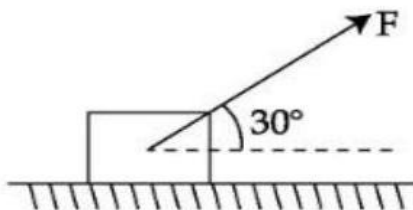

- Sol. (1) 20 N (2) 33.3 N (3) 25.2 N (4) 35.7 N

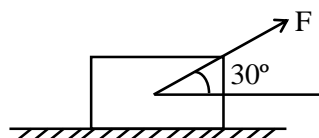

Given $m = 10$ kg, $\mu_s = 0.25$, $\theta = 30^\circ$, $g = 10 \text{m/sec}$.

F.B.D. (Free Body Diagram)

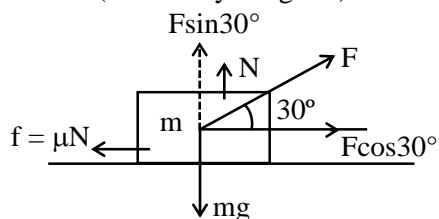

$$F \cos 30^\circ = f \quad \dots(1)$$

$$F \sin 30^\circ + N = mg \Rightarrow N = Mg - F \sin 30^\circ \dots(2)$$

From equation (1)

$$F \sin 30^\circ = \mu_s N$$

$$F \cos 30^\circ = \mu_s (mg - F \sin 30^\circ)$$

$$F \cos 30^\circ = \mu_s mg - \mu_s F \sin 30^\circ$$

$$F (\cos 30^\circ + \mu_s \sin 30^\circ) = \mu_s mg$$

$$F = \frac{\mu_s mg}{\cos 30^\circ + \mu_s \sin 30^\circ} = \frac{0.25 \times 10 \times 10}{\sqrt{3}/2 + 0.25 \times 1/2}$$

$$F = \frac{25}{\sqrt{3}/2 + \frac{0.25}{2}} = \frac{50}{1.73 + 0.25} = \frac{50}{1.98} = 25.2 \text{ N}$$

- 19.** The escape velocities of two planets A and B are in the ratio 1: 2. If the ratio of their radii respectively is 1: 3, then the ratio of acceleration due to gravity of planet A to the acceleration of gravity of planet B will be :

$$(1) \frac{3}{2}$$

$$(2) \frac{2}{3}$$

$$(3) \frac{3}{4}$$

$$(4) \frac{4}{3}$$

Sol. (3)

Given :

$$\frac{v_A}{v_B} = \frac{1}{2}$$

$$\frac{r_A}{r_B} = \frac{1}{3}$$

$$\frac{g_A}{g_B} = ?$$

$$g_B$$

As we know,

$$v = \sqrt{\frac{2GM}{R}}$$

Hence,

$$\frac{v_A}{v_B} = \frac{\sqrt{\frac{2GM_A}{R_A}}}{\sqrt{\frac{2GM_B}{R_B}}} = \sqrt{\frac{M_A R_B}{M_B R_A}} = \frac{1}{2} \dots(1)$$

$$\text{Given : } \frac{R_A}{R_B} = \frac{1}{3} \dots(2)$$

Therefore,

$$\begin{aligned} \frac{g_A}{g_B} &= \frac{M_A R_A^2}{M_B R_B^2} \\ &= \frac{1}{4} \times \frac{1}{3} \times 9 \\ &= \frac{3}{4} \end{aligned}$$

- 20.** For a body projected at an angle with the horizontal from the ground, choose the correct statement.
- (1) The vertical component of momentum is maximum at the highest point.
 - (2) The Kinetic Energy (K.E.) is zero at the highest point of projectile motion.
 - (3) The horizontal component of velocity is zero at the highest point.
 - (4) Gravitational potential energy is maximum at the highest point.

Sol. (4)

At highest point height is maximum and vertical component of velocity is zero.
So momentum is zero.

At highest point horizontal component of velocity will not be zero but vertical component of velocity is equal to zero and because of this K.E. will not be equal to zero.

Gravitational potential energy is maximum at highest point and equal to $mgH = mg\left(\frac{u^2 \sin^2 \theta}{2g}\right)$

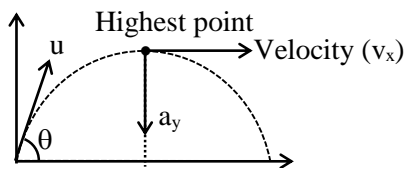

Therefore the correct option is (4).

SECTION - B

- 21.** A block is fastened to a horizontal spring. The block is pulled to a distance $x = 10$ cm from its equilibrium position (at $x = 0$) on a frictionless surface from rest. The energy of the block at $x = 5$ cm is 0.25 J. The spring constant of the spring is _____ Nm^{-1}

Sol. (50)

Given

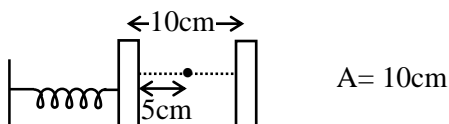

At any instant total energy for free oscillation remains constant $= \frac{1}{2}kA^2$

$$\Rightarrow \frac{1}{2}kA^2 = 0.25\text{J}$$

$$\Rightarrow \frac{1}{2}kA^2 = 0.25\text{J} \Rightarrow k = \frac{0.25 \times 2}{A^2}$$

$$\Rightarrow k = \frac{0.50}{(10\text{cm})^2} = \frac{0.50}{(10 \times 10^{-2})^2} = \frac{0.50 \times 10^4}{100}$$

$$k = 0.50 \times 100 = 50 \text{ N/m}$$

- 22.** A square shaped coil of area 70 cm^2 having 600 turns rotates in a magnetic field of 0.4 wbm^{-2} , about an axis which is parallel to one of the side of the coil and perpendicular to the direction of field. If the coil completes 500 revolution in a minute, the instantaneous emf when the plane of the coil is inclined at 60° with the field, will be _____ V. (Take $\pi = \frac{22}{7}$)

Sol. (44)

$$\text{Area (A)} = 70 \text{ cm}^2 = 70 \times 10^{-4} \text{ m}^2$$

$$B = 0.4 \text{ T}$$

$$f = \frac{500 \text{ revolution}}{60 \text{ minute}} = \frac{500 \text{ rev.}}{60 \text{ sec.}}$$

Induced emf in rotating coil is given by

$$\begin{aligned}
 e &= N\omega BA \sin \theta \\
 &= 600 \times 2 \times \frac{22}{7} \times \frac{500}{60} \times 0.4 \times 70 \times 10^{-4} \sin 30^\circ \\
 &= 600 \times 2 \times \frac{22}{7} \times \frac{500}{6} \times 0.4 \times 70 \times 10^{-4} \times \frac{1}{2} \\
 &= 44 \text{ Volt}
 \end{aligned}$$

- 23.** As shown in the figure, in Young's double slit experiment, a thin plate of thickness $t = 10\mu\text{m}$ and refractive index $\mu = 1.2$ is inserted in front of slit S_1 . The experiment is conducted in air ($\mu = 1$) and uses a monochromatic light of wavelength $\lambda = 500 \text{ nm}$. Due to the insertion of the plate, central maxima is shifted by a distance of $x\beta_0$. β_0 is the fringe-width before the insertion of the plate. The value of the x is _____.

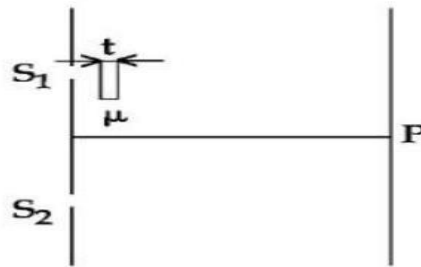

Sol. (4)

Given $t = 10 \times 10^{-6} \text{ m}$

$\mu = 1.2$

$\lambda = 500 \times 10^{-9} \text{ m}$

When the glass slab inserted in front of one slit then the shift of central fringe is obtained by

$$t = \frac{n\lambda}{(\mu - 1)}$$

$$\Rightarrow 10 \times 10^{-6} = \frac{n \times 500 \times 10^{-9}}{(1.2 - 1)}$$

$$10 \times 10^{-6} = \frac{n \times 500 \times 10^{-9}}{0.2}$$

$$\boxed{n = 4}$$

- 24.** Moment of inertia of a disc of mass M and radius ' R ' about any of its diameter is $\frac{MR^2}{4}$. The moment of inertia of this disc about an axis normal to the disc and passing through a point on its edge will be, $\frac{x}{2}MR^2$. The value of x is _____.

Sol. (3)

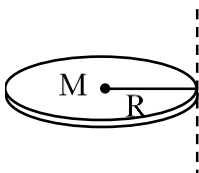

By using parallel axis theorem

$$I' = I_0 + MR^2$$

$$I' = \frac{MR^2}{2} + MR^2$$

$$I' = \frac{3MR^2}{2}$$

Given $I' = \frac{x}{2}MR^2$

$$\therefore \frac{3MR^2}{2} = \frac{x}{2}MR^2$$

$$x = 3$$

- 25.** For a train engine moving with speed of 20 ms^{-1} , the driver must apply brakes at a distance of 500 m before the station for the train to come to rest at the station. If the brakes were applied at half of this distance, the train engine would cross the station with speed $\sqrt{x} \text{ ms}^{-1}$. The value of x is _____.
(Assuming same retardation is produced by brakes)

Sol. (200)

By using 3rd equation of motion

$$v^2 = u^2 + 2as$$

$$(0)^2 = u^2 + 2as$$

$$u^2 = -2as$$

$$S = \frac{u^2}{2a} = \frac{(20)^2}{2 \times a} = 500$$

acceleration of the train, $a = -\frac{400}{1000} = -0.4 \text{ m/sec}$

Now, if the brakes are applied at $S = 250 \text{ m}$ i.e. half of the distance

$$v^2 = u^2 + 2as$$

$$v^2 = (20)^2 + 2(-0.4) \times 250$$

$$v^2 = 400 - 2 \times \frac{4}{10} \times 250$$

$$v^2 = 200$$

$$v = \sqrt{200}$$

Given $\Rightarrow v = \sqrt{x}$

$$\boxed{x = 200}$$

- 26.** A cubical volume is bounded by the surfaces $x = 0, x = a, y = 0, y = a, z = 0, z = a$. The electric field in the region is given by $\vec{E} = E_0x\hat{i}$. Where $E_0 = 4 \times 10^4 \text{ NC}^{-1} \text{ m}^{-1}$. If $a = 2 \text{ cm}$, the charge contained in the cubical volume is $Q \times 10^{-14} \text{ C}$. The value of Q is _____. (Take $\epsilon_0 = 9 \times 10^{-12} \text{ C}^2/\text{Nm}^2$)

Sol. 288

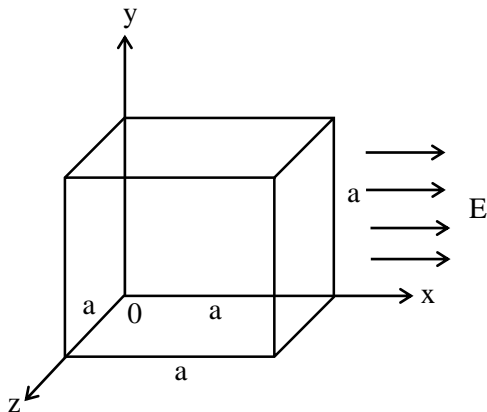

$$\phi = \vec{E} \cdot \vec{A}$$

$$E = E_0a\hat{i}$$

$$\phi = E_0 a \cdot a^2 = E_0 a^3$$

$$q_{\text{enc.}} = \phi \epsilon_0$$

$$q_{\text{enc.}} = E_0 a^3 \epsilon_0$$

$$= 4 \times 10^4 \times 8 \times 10^{-6} \times 9 \times 10^{-12}$$

$$q_{\text{enc.}} = 288 \times 10^{-14} \text{ C}$$

Hence the value of Q is 288.

- 27.** A force $F = (5 + 3y^2)$ acts on a particle in the y -direction, where F is in newton and y is in meter. The work done by the force during a displacement from $y = 2$ m to $y = 5$ m is _____ J.

Sol. 132 J

Given :

$F = (5 + 3y^2)$ in the y direction

Work done is given by

$$W = \int_{y_1}^{y_2} F \cdot dy$$

$$y_1 = 2 \text{ m}, \quad y_2 = 5 \text{ m}$$

$$W = \int_2^5 (5 + 3y^2) dy$$

$$W = \int_2^5 5 dy + \int_2^5 3y^2 dy$$

$$W = [5y]_2^5 + \left[\frac{3y^3}{3} \right]_2^5$$

$$W = (5 \times 5 - 5 \times 2) + (125 - 8)$$

$$W = (25 - 10) + 117$$

$$\boxed{W = 132 \text{ Joule}}$$

- 28.** The surface of water in a water tank of cross section area 750 cm^2 on the top of a house is h m above the tap level. The speed of water coming out through the tap of cross section area 500 mm^2 is 30 cm/s . At that instant, $\frac{dh}{dt}$ is $x \times 10^{-3} \text{ m/s}$. The value of x will be _____.

Sol. (2)

By using equation of continuity

$$A_1 v_1 = A_2 v_2$$

$$750 \times 10^{-4} \times v_1 = 500 \times 10^{-6} \times 30 \times 10^{-2}$$

$$v_1 = 20 \times 10^{-4} \text{ m/sec}$$

$$v_1 = 2 \times 10^{-3} \text{ m / sec}$$

$$\text{Given : } \frac{dh}{dt} = v = x \times 10^{-3} \text{ m/sec.}$$

$$\text{Therefore } \boxed{x = 2}$$

29. In the given circuit, the value of $\left| \frac{I_1 + I_3}{I_2} \right|$ is _____.

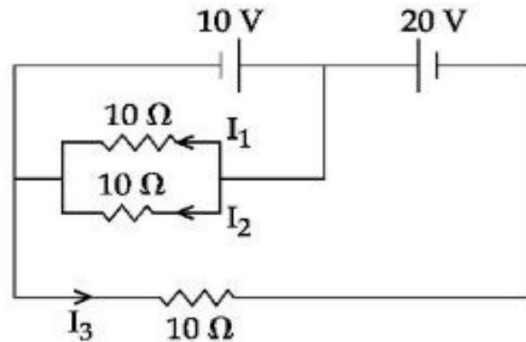

Sol. (2)

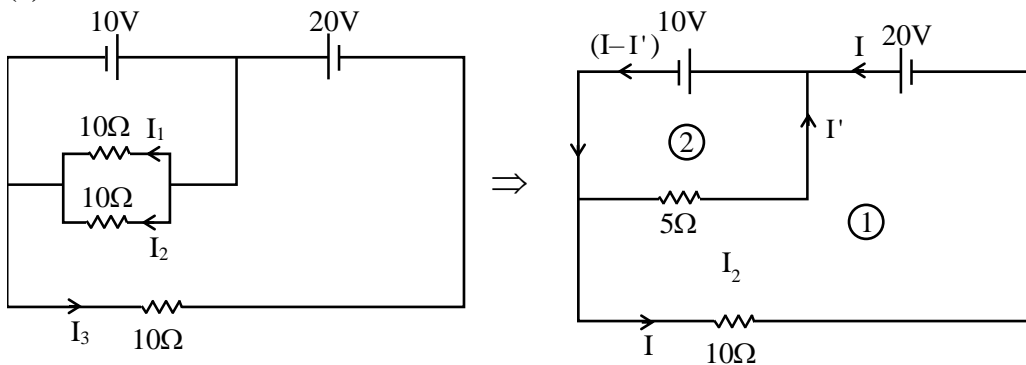

Apply KVL in loop (1)

$$20 - 10 - 10I = 0$$

Or $I = 1 \text{ Amp}$

Apply KVL in loop (2)

$$-10 + 5I' = 0$$

Or $I' = 2 \text{ Amp}$

On comparing $I_3 = 1 \text{ A}$

$$I_2 = I_1 = \frac{I'}{2} = 1 \text{ Amp}$$

So, the value of $\left| \frac{I_1 + I_3}{I_2} \right| = \left| \frac{1+1}{1} \right| = 2 \text{ Amp}.$

30. Nucleus A having $Z = 17$ and equal number of protons and neutrons has 1.2 MeV binding energy per nucleon. Another nucleus B of $Z = 12$ has total 26 nucleons and 1.8 MeV binding energy per nucleons. The difference of binding energy of B and A will be _____ MeV.

Sol. 6 MeV

For Nucleus A

$Z = 17 =$ Number of protons

Given $(Z = N) \therefore N = 17$

$A = 34 = Z + N$

$E_{bn} = 1.2 \text{ MeV}$

$$\frac{(E_B)_1}{A} = 1.2 \text{ MeV}$$

$$(E_B)_1 = (1.2 \text{ MeV}) \times A$$

$$(E_B)_1 = (1.2 \text{ MeV}) \times 34$$

$$\boxed{(E_B)_1 = 40.8 \text{ MeV}} \rightarrow \text{Binding energy of Nucleus A.}$$

For Nucleus B

$$Z = 12, A = 26$$

$$E_{\text{bn}} = 1.8\text{MeV}$$

$$\frac{(E_{\text{b}})_2}{A} = 1.8\text{MeV}$$

$$(E_{\text{b}})_2 = (1.8\text{MeV}) \times A$$

$$(E_{\text{b}})_2 = (1.8\text{MeV}) \times 26$$

$$\boxed{(E_{\text{b}})_2 = 46.8\text{MeV}} \rightarrow \text{Binding energy of nucleus B}$$

Therefore, difference in binding energy of B and A is

$$\begin{aligned} \Delta E_{\text{b}} &= (E_{\text{b}})_2 - (E_{\text{b}})_1 \\ &= 46.8\text{MeV} - 40.8\text{MeV} = 6\text{MeV} \end{aligned}$$

34. The correct order of bond enthalpy (kJmol^{-1}) is :
- (1) $\text{C} - \text{C} > \text{Si} - \text{Si} > \text{Sn} - \text{Sn} > \text{Ge} - \text{Ge}$ (2) $\text{C} - \text{C} > \text{Si} - \text{Si} > \text{Ge} - \text{Ge} > \text{Sn} - \text{Sn}$
 (3) $\text{Si} - \text{Si} > \text{C} - \text{C} > \text{Sn} - \text{Sn} > \text{Ge} - \text{Ge}$ (4) $\text{Si} - \text{Si} > \text{C} - \text{C} > \text{Ge} - \text{Ge} > \text{Sn} - \text{Sn}$

Sol. 2

Bond length \uparrow Bond energy \downarrow

35. Given below are two **statements** : one is labelled as **Assertion (A)** and the other is labelled as **Reason (R)**.

Assertion (A) : An aqueous solution of KOH when used for volumetric analysis, its concentration should be checked before the use.

Reason (R) : On aging, KOH solution absorbs atmospheric CO_2 .

In the light of the above statements, choose the correct answer from the options given below :

- (1) Both (A) and (R) are correct but (R) is not the correct explanation of (A)
 (2) (A) is correct but (R) is not correct
 (3) Both (A) and (R) are correct and (R) is the correct explanation of (A)
 (4) (A) is not correct but (R) is correct

Sol. 3

KOH absorb CO_2

So its concentration should be checked.

36. O – O bond length in H_2O_2 is X than the O – O bond length in F_2O_2 . The O – H bond length in H_2O_2 is Y than that of the O – F bond in F_2O_2 .

Choose the correct option for X and Y from those given below

- (1) X-shorter, Y - longer (2) X-shorter, Y-shorter
 (3) X - longer, Y-shorter (4) X-longer, Y – longer

Sol. 3

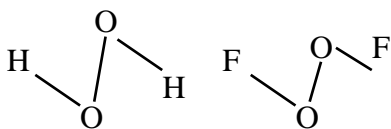

\rightarrow (O – O) BL in H_2O_2 is longer than (O–O) BL in O_2F_2

\rightarrow (O–H) BL in H_2O_2 is shorter than (O–F) BL in O_2F_2

37. Given below are two **statements** : one is labelled as **Assertion (A)** and the other is labelled as **Reason (R)**.

Assertion (A): Cu^{2+} in water is more stable than Cu^+ .

Reason (R) : Enthalpy of hydration for Cu^{2+} is much less than that of Cu^+ .

In the light of the above statements, choose the correct answer from the options given below :

- (1) Both (A) and (R) are correct and (R) is the correct explanation of (A)
 (2) (A) is not correct but (R) is correct
 (3) (A) is correct but (R) is not correct
 (4) Both (A) and (R) are correct but (R) is not the correct explanation of (A)

Sol. 1



The stability of $\text{Cu}^{2+}(\text{aq})$ rather than $\text{Cu}^+(\text{aq})$, is due to the much more negative $\Delta_{\text{hyd}}H$ of $\text{Cu}^{2+}(\text{aq})$ than $\text{Cu}^+(\text{aq})$, which more than compensates for the second ionisation enthalpy of Cu.

38.

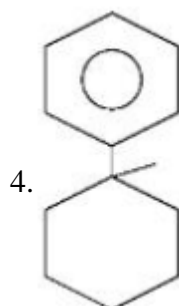
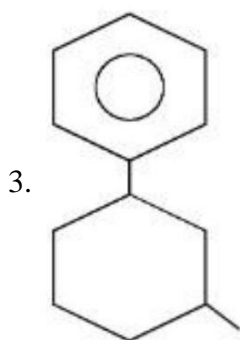
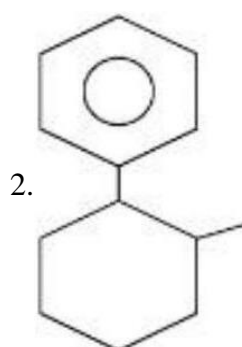
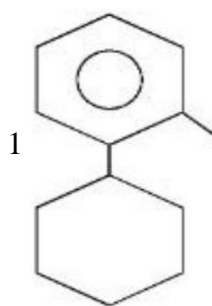
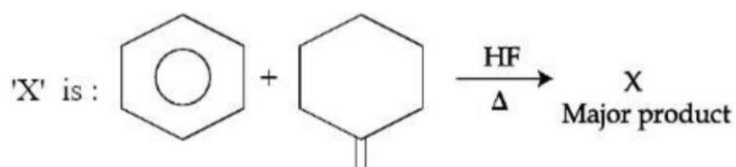

Sol. 4

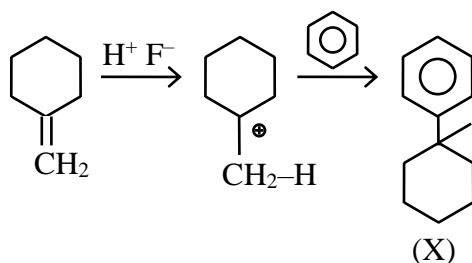

39. The complex cation which has two isomers is :

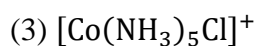
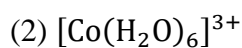
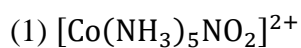

Sol. 1

NO_2^- is ambidentate ligand, so. $[\text{Co}(\text{NH}_3)_5\text{NO}_2]^{2+}$ will show 2 Isomer.

40. The graph which represents the following reaction is :

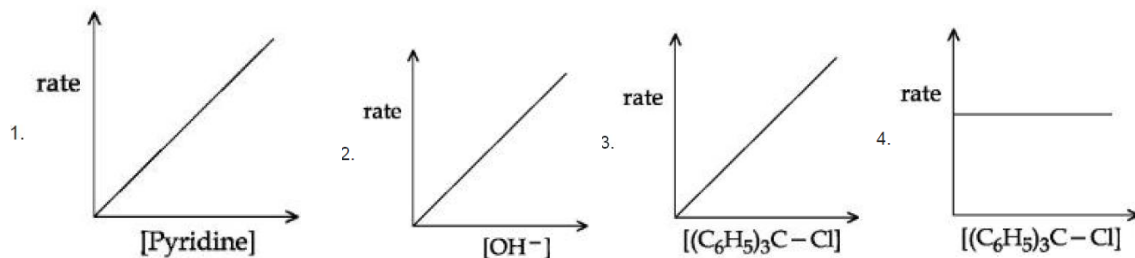
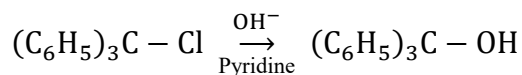

Sol. 3

41. Given below are two **statements** : one is labelled as **Assertion (A)** and the other is labelled as **Reason (R)**.

Assertion (A) : α -halocarboxylic acid on reaction with dil NH_3 gives good yield of α -amino carboxylic acid whereas the yield of amines is very low when prepared from alkyl halides.

Reason (R) : Amino acids exist in zwitter ion form in aqueous medium.

In the light of the above statements, choose the correct answer from the options given below :

- (1) Both (A) and (R) are correct and (R) is the correct explanation of (A)
- (2) (A) is not correct but (R) is correct
- (3) Both (A) and (R) are correct but (R) is not the correct explanation of (A)
- (4) (A) is correct but (R) is not correct

Sol. 1

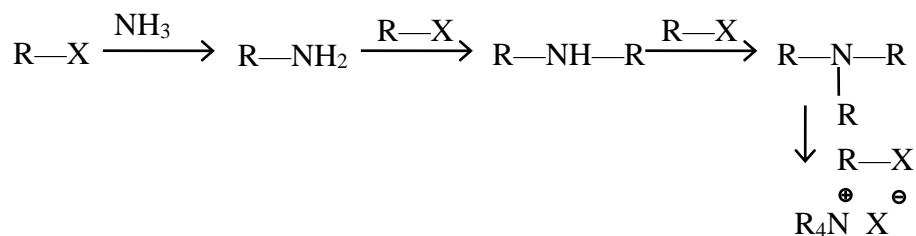
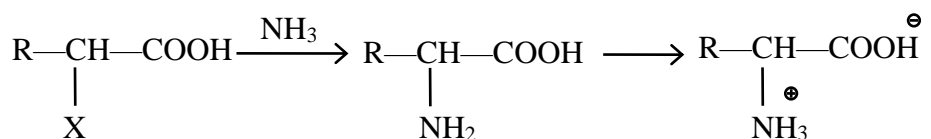

42. The industrial activity held least responsible for global warming is :

- (1) Industrial production of urea
- (2) Electricity generation in thermal power plants
- (3) steel manufacturing
- (4) manufacturing of cement

Sol. 1

43. Given below are two **statements** : one is labelled as **Assertion (A)** and the other is labelled as **Reason (R)**.

Assertion (A) : Gypsum is used for making fireproof wall boards.

Reason (R): Gypsum is unstable at high temperatures.

In the light of the above statements, choose the correct answer from the options given below :

- (1) Both (A) and (R) are correct and (R) is the correct explanation of (A)
- (2) Both (A) and (R) are correct but (R) is not the correct explanation of (A)
- (3) (A) is correct but (R) is not correct
- (4) (A) is not correct but (R) is correct

Sol. 2

Gypsum is used for making fireproof wall board.

44. The starting material for convenient preparation of deuterated hydrogen peroxide (D_2O_2) in laboratory is :

- (1) BaO
- (2) $K_2S_2O_8$
- (3) BaO_2
- (4) 2-ethylanthraquinol

Sol. 2

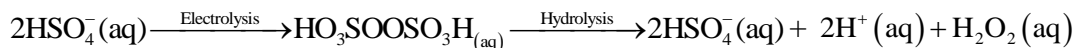

This method is now used for the laboratory preparation of D_2O_2 .

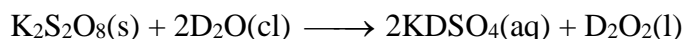

45. The effect of addition of helium gas to the following reaction in equilibrium state, is :

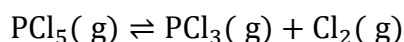

- (1) helium will deactivate PCl_5 and reaction will stop.
- (2) the equilibrium will shift in the forward direction and more of Cl_2 and PCl_3 gases will be produced.
- (3) the equilibrium will go backward due to suppression of dissociation of PCl_5 .
- (4) addition of helium will not affect the equilibrium.

Sol. 2

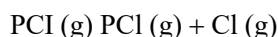

(Case 1) : At constant P – volume will increase so reaction will shift in forward direction then answer will be A

Case 2 : At constant volume no change in active mass so reaction will not shift in any direction then answer will be D.

46. Which element is not present in Nessler's reagent ?

- (1) Oxygen
- (2) Potassium
- (3) Mercury
- (4) Iodine

Sol. 1



47. The structures of major products A, B and C in the following reaction are sequence.

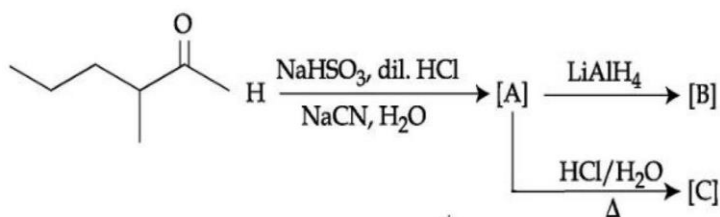

- (1) A = CCCC(C)C(O)OS(=O)(=O)[Na], B = CCCC(C)C(O)H, C = CCCC(C)C(Cl)H
- (2) A = CCCC(C)(O)(CN)H, B = CCCC(C)(O)(CHO)H, C = CCCC(C)(O)(CO(=O)O)H
- (3) A = CCCC(C)(O)(S(=O)(=O)O)H, B = CCCC(C)CO, C = CCCC(C)(O)(S(=O)(=O)Cl)H
- (4) A = CCCC(C)(O)(CN)H, B = CCCC(C)(O)(CN)H, C = CCCC(C)(O)(CO(=O)O)H

Sol. 4

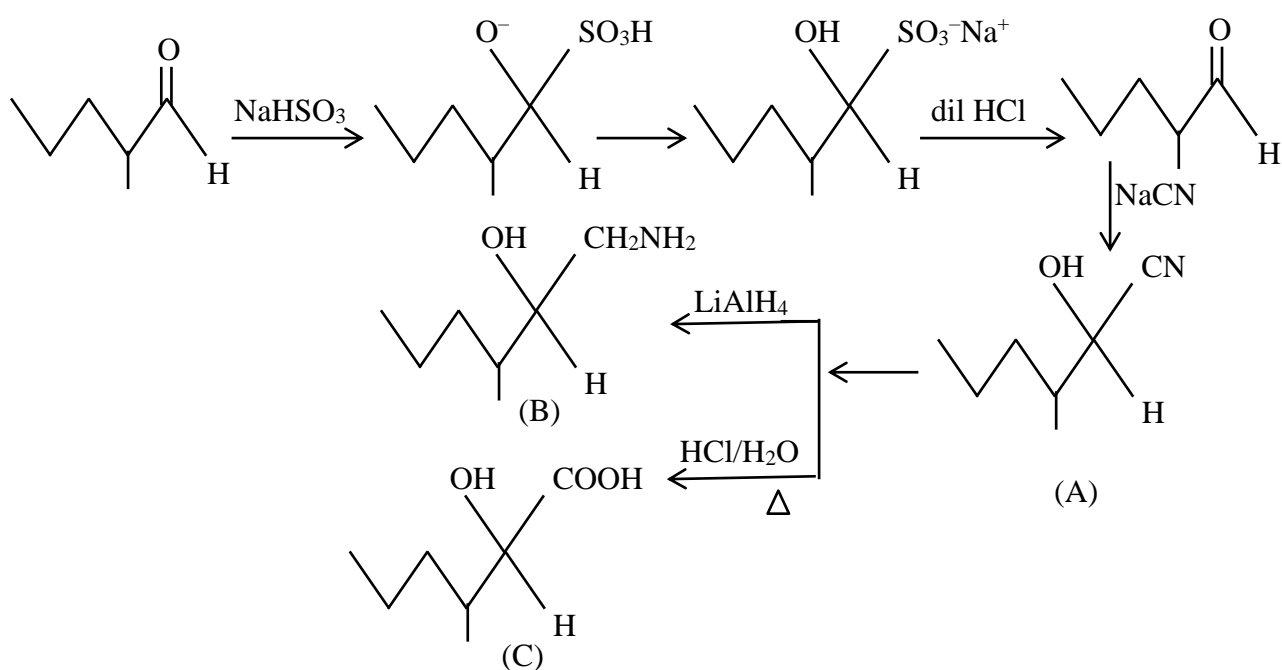

48. In a reaction,

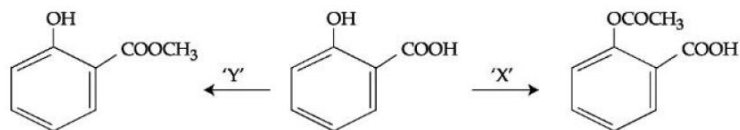

reagents 'X' and 'Y' respectively are :

- (1) $(\text{CH}_3\text{CO})_2\text{O}/\text{H}^+$ and $(\text{CH}_3\text{CO})_2\text{O}/\text{H}^+$ (2) $\text{CH}_3\text{OH}/\text{H}^+, \Delta$ and $(\text{CH}_3\text{CO})_2\text{O}/\text{H}^+$
 (3) $\text{CH}_3\text{OH}/\text{H}^+, \Delta$ and $\text{CH}_3\text{OH}/\text{H}^+, \Delta$ (4) $(\text{CH}_3\text{CO})_2\text{O}/\text{H}^+$ and $\text{CH}_3\text{OH}/\text{H}^+, \Delta$

Sol. 4

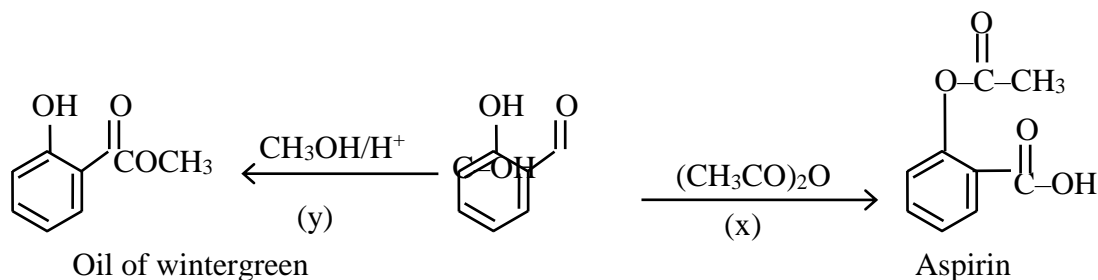

49. Which one of the following sets of ions represents a collection of isoelectronic species ?

(Given: Atomic Number : F: 9, Cl: 17, Na = 11, Mg = 12, Al = 13, K = 19, Ca = 20, Sc = 21)

- (1) $\text{Ba}^{2+}, \text{Sr}^{2+}, \text{K}^+, \text{Ca}^{2+}$ (2) $\text{Li}^+, \text{Na}^+, \text{Mg}^{2+}, \text{Ca}^{2+}$
 (3) $\text{N}^{3-}, \text{O}^{2-}, \text{F}^-, \text{S}^{2-}$ (4) $\text{K}^+, \text{Cl}^-, \text{Ca}^{2+}, \text{Sc}^{3+}$

Sol. 4

$$\text{K}^+ = 18$$

$$\text{Cl}^- = 18$$

$$\text{Ca}^{+2} = 18$$

$$\text{Sc}^{+3} = 18$$

50. Given below are two statements :

Statement I : Sulphanilic acid gives esterification test for carboxyl group.

Statement II : Sulphanilic acid gives red colour in Lassigne's test for extra element detection.

In the light of the above statements, choose the most appropriate answer from the options given below:

- (1) Statement I is incorrect but Statement II is correct
 (2) Both Statement I and Statement II are incorrect
 (3) Statement I is correct but Statement II is incorrect
 (4) Both Statement I and Statement II are correct

Sol. 1

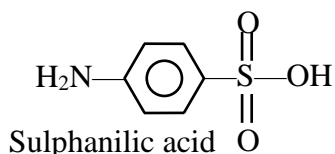

Does not show esterification test. Presence of both sulphur and nitrogen give red colour in Lassigne's test.

SECTION B

51. 0.3 g of ethane undergoes combustion at 27°C in a bomb calorimeter. The temperature of calorimeter system (including the water) is found to rise by 0.5°C . The heat evolved during combustion of ethane at constant pressure is _____ kJmol^{-1} . (Nearest integer)

[Given : The heat capacity of the calorimeter system is 20 kJ K^{-1} , $R = 8.3 \text{ J K}^{-1} \text{ mol}^{-1}$.

Assume ideal gas behaviour.

Atomic mass of C and H are 12 and 1 g mol^{-1} respectively]

Sol. 1006

(Bomb calorimeter \rightarrow const volume Heat released By combustion of 1 mole

$$\text{C}_2\text{H}_6(\Delta U) = -\frac{20 \times 0.5}{0.3} \times 30 = -1000 \text{ kJ}$$

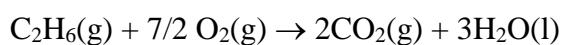

$$\Delta n_{\text{g}} = 2 - (2 + 7/2) = -(7/2)$$

$$\Delta H = \Delta U + \Delta n_{\text{g}}RT$$

$$= -1000 - 7/2 \times 8.3 \times 300 \text{ kJ}$$

$$= -1000 - 6.225$$

$$= -1006 \text{ kJ}$$

So heat released = 1006 kJ mol^{-1}

52. Among the following, the number of tranquilizer/s is/are _____

A. Chlorliazepoxide

B. Veronal

C. Valium

D. Salvarsan

Sol. 3

A. Chlorliazepoxide (Tranquilizer)

B. Veronal (Tranquilizer)

C. Valium (Tranquilizer)

D. Salvarsan (Antibiotic)

53. Among following compounds, the number of those present in copper matte is

A. CuCO_3

B. Cu_2S

C. Cu_2O

D. FeO

Sol. 1

Copper matte $\rightarrow \text{Cu}_2\text{S}$

54. A metal M crystallizes into two lattices :- face centred cubic (fcc) and body centred cubic (bcc) with unit cell edge length of 2.0 and 2.5Å respectively. The ratio of densities of lattices fcc to bcc for the metal M is _____ (Nearest integer)

Sol. 4

$$d = \frac{Z \times M}{N_A a^3}$$

$$\frac{d_{\text{FCC}}}{d_{\text{BCC}}} = \frac{\frac{4 \times M_w}{N_A \times (2)^3}}{\frac{2 \times M_w}{N_A \times (2.5)^3}} = 3.90$$

55. The spin only magnetic moment of $[\text{Mn}(\text{H}_2\text{O})_6]^{2+}$ complexes is _____ B.M. (Nearest integer)
(Given: Atomic no. of Mn is 25)

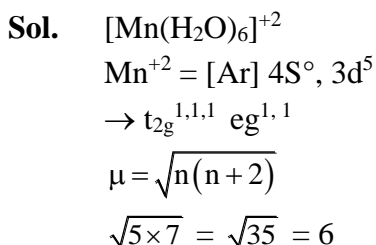

56. $1 \times 10^{-5} \text{M AgNO}_3$ is added to 1 L of saturated solution of AgBr. The conductivity of this solution at 298 K is _____ $\times 10^{-8} \text{ S m}^{-1}$

[Given : $K_{\text{SP}}(\text{AgBr}) = 4.9 \times 10^{-13}$ at 298 K

$$\lambda_{\text{Ag}^+}^0 = 6 \times 10^{-3} \text{ S m}^2 \text{ mol}^{-1}$$

$$\lambda_{\text{Br}^-}^0 = 8 \times 10^{-3} \text{ S m}^2 \text{ mol}^{-1}$$

$$\lambda_{\text{NO}_3^-}^0 = 7 \times 10^{-3} \text{ S m}^2 \text{ mol}^{-1}]$$

Sol. 14

$$[\text{Ag}^+] = 10^{-5}$$

$$[\text{NO}_3^-] = 10^{-5}$$

$$[\text{Br}^-] = \frac{K_{\text{sp}}}{[\text{Ag}^+]} = 4.9 \times 10^{-8}$$

$$\wedge_m = \frac{k}{1000 \times M}$$

For Ag^+

$$6 \times 10^{-3} = \frac{K_{\text{Ag}^+}}{1000 \times 10^{-5}}$$

$$K_{\text{Ag}^+} = 6 \times 10^{-8}$$

$$= 6000 \times 10^{-8}$$

for Br^-

$$8 \times 10^{-3} = \frac{K_{\text{Br}^-}}{1000 \times 4.9 \times 10^{-8}}$$

$$K_{\text{Br}^-} = 39.2 \times 10^{-8}$$

for NO_3^-

$$7 \times 10^{-3} = \frac{K_{\text{NO}_3^-}}{1000 \times 10^{-5}}$$

$$K_{\text{NO}_3^-} = 7 \times 10^{-5}$$

$$= 7000 \times 10^{-8}$$

Conductivity of solution

$$= (6000 + 7000 + 39.2) \times 10^{-8}$$

$$= 13039.2 \times 10^{-8} \text{ Sm}^{-1}$$

57. 20% of acetic acid is dissociated when its 5 g is added to 500 mL of water. The depression in freezing point of such water is _____ $\times 10^{-3} \text{ }^\circ\text{C}$

Atomic mass of C, H and O are 12, 1 and 16 a.m.u. respectively.

[Given : Molal depression constant and density of water are $1.86 \text{ K kg mol}^{-1}$ and 1 g cm^{-3} respectively.]

Sol. 372

$$i = 1 + (n - 1) \alpha$$

$$(i = 1 + 0.2(2 - 1) = 1.2)$$

$$\Delta T_f = i K_f m$$

$$\Delta T_f = 1.2 \times 1.86 \times \frac{5 \times 1000}{60 \times 500}$$

$$\Delta t_f = 3.72$$

$$\Delta T_f = 372 \times 10^{-2}$$

58. $A \rightarrow B$

The above reaction is of zero order. Half life of this reaction is 50 min. The time taken for the concentration of A to reduce to one-fourth of its initial value is _____ (Nearest integer) min.

Sol. 75

Assume reaction starts with 1 mole A

$$\left(t_{1/2} = \frac{a}{2k}, K = \frac{1}{2 \times 50} \right)$$

For 75% completion

$$a - \frac{a}{4} = kt$$

$$t = \frac{3a}{4k} = \frac{3}{4} \times \frac{100}{a} = 75$$

59. Testosterone, which is a steroidal hormone, has the following structure.

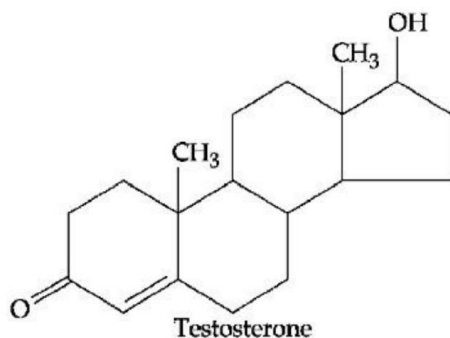

The total number of asymmetric carbon atom /s in testosterone is _____

Sol. 6

60. The molality of a 10%(v/v) solution of di-bromine solution in CCl_4 (carbon tetrachloride) is 'x'.
 $x = \text{_____} \times 10^{-2} \text{M}$. (Nearest integer)

[Given : molar mass of $\text{Br}_2 = 160 \text{ g mol}^{-1}$

atomic mass of C = 12 g mol^{-1}

atomic mass of Cl = 35.5 g mol^{-1}

density of dibromine = 3.2 g cm^{-3}

density of $\text{CCl}_4 = 1.6 \text{ g cm}^{-3}$]

Sol. 139

(10 ml solute in 90 ml solvent

mass of solute = $10 \times 3.2 = 32 \text{g}$

mass of solvent = $90 \times 1.6 \text{g}$

$$m = \frac{32 \times 1000}{160 \times 90 \times 1.6} = 1.388$$

$$m = 138.8 \times 10^{-2} = 139$$

Mathematics

SECTION - A

61. Let $\alpha x = \exp(x^\beta y^\gamma)$ be the solution of the differential equation $2x^2y \, dy - (1 - xy^2) \, dx = 0$, $x > 0$, $y(2) = \sqrt{\log_e 2}$. Then $\alpha + \beta + \gamma$ equals :
- (1) 1 (2) -1 (3) 3 (4) 0

Sol. 1

$$2x^2y \, dy - (1 - xy^2) \, dx = 0$$

$$\Rightarrow 2x^2y \frac{dy}{dx} - 1 + xy^2 = 0$$

$$\Rightarrow 2y \frac{dy}{dx} - \frac{1}{x^2} + \frac{y^2}{x} = 0$$

$$\Rightarrow 2y \frac{dy}{dx} + \frac{y^2}{x} = \frac{1}{x^2} \text{ (L.D.E)}$$

$$y^2 = t \Rightarrow 2y \frac{dy}{dx} = \frac{dt}{dx}$$

$$\frac{dt}{dx} + \frac{t}{x} = \frac{1}{x^2}$$

$$f = e^{\int \frac{1}{x} dx} = x$$

$$\Rightarrow t \times x = \int x \cdot \frac{1}{x^2} dx$$

$$\Rightarrow y^2 \cdot x = \ln x + c$$

$$\text{Also, } y(2) = \sqrt{\log_e 2}$$

$$\log_e^2 2 = \log_e 2 + c \Rightarrow c = \log_e 2$$

$$\Rightarrow y^2 x = \ln x + \ln 2$$

$$\Rightarrow y^2 x = \ln 2x$$

$$2x = \exp(x^1 y^2)$$

Compare it with given solution we get,

$$\alpha = 2, \beta = 1, \gamma = 2$$

$$\Rightarrow \alpha + \beta - \gamma = 2 + 1 - 2 = 1$$

62. The sum $\sum_{n=1}^{\infty} \frac{2n^2 + 3n + 4}{(2n)!}$ is equal to :

(1) $\frac{13e}{4} + \frac{5}{4e}$

(2) $\frac{11e}{2} + \frac{7}{2e} - 4$

(3) $\frac{11e}{2} + \frac{7}{2e}$

(4) $\frac{13e}{4} + \frac{5}{4e} - 4$

Sol. 4

$$\sum_{n=1}^{\infty} \frac{2n^2 + 3n + 4}{(2n)!}$$

$$\frac{1}{2} \sum_{n=1}^{\infty} \frac{2n(2n-1) + 8n + 8}{(2n)!}$$

$$\frac{1}{2} \sum_{n=1}^{\infty} \frac{1}{(2n-2)!} + 2 \sum_{n=1}^{\infty} \frac{1}{(2n-1)!} + 4 \sum_{n=1}^{\infty} \frac{1}{(2n)!}$$

$$e = 1 + 1 + \frac{1}{2!} + \frac{1}{3!} + \frac{1}{4!} + \dots$$

$$e^{-1} = 1 - 1 + \frac{1}{2!} - \frac{1}{3!} + \frac{1}{4!} + \dots$$

$$\left(e + \frac{1}{e} \right) = 2 \left(1 + \frac{1}{2!} + \frac{1}{4!} + \dots \right)$$

$$e - \frac{1}{e} = \left(1 + \frac{1}{3!} + \frac{1}{5!} + \dots \right)$$

Now

$$\frac{1}{2} \left(\sum_{n=1}^{\infty} \frac{1}{(2n-2)!} \right) + 2 \sum_{n=1}^{\infty} \frac{1}{(2n-1)!} + 4 \sum_{n=1}^{\infty} \frac{1}{(2n)!}$$

$$= \frac{1}{2} \left[\frac{e + \frac{1}{e}}{2} \right] + 2 \left[\frac{e - \frac{1}{e}}{2} \right] + 4 \left[\frac{e + \frac{1}{e} - 2}{2} \right]$$

$$= \frac{\left(e + \frac{1}{e} \right)}{4} + e - \frac{1}{e} + 2e + \frac{2}{e} - 4$$

$$= \frac{13}{4}e + \frac{5}{4e} - 4$$

63. Let $\vec{a} = 5\hat{i} - \hat{j} - 3\hat{k}$ and $\vec{b} = \hat{i} + 3\hat{j} + 5\hat{k}$ be two vectors. Then which one of the following statements is TRUE ?

(1) Projection of \vec{a} on \vec{b} is $\frac{17}{\sqrt{35}}$ and the direction of the projection vector is same as of \vec{b} .

(2) Projection of \vec{a} on \vec{b} is $\frac{17}{\sqrt{35}}$ and the direction of the projection vector is opposite to the direction of \vec{b} .

(3) Projection of \vec{a} on \vec{b} is $\frac{-17}{\sqrt{35}}$ and the direction of the projection vector is same as of \vec{b} .

(4) Projection of \vec{a} on \vec{b} is $\frac{-17}{\sqrt{35}}$ and the direction of the projection vector is opposite to the direction of \vec{b} .

Sol. Bonus

Projection of \vec{a} on $\vec{b} = \frac{\vec{a} \cdot \vec{b}}{|\vec{b}|}$

$$\Rightarrow \frac{(5\hat{i} - \hat{j} - 3\hat{k}) \cdot (\hat{i} + 3\hat{j} + 5\hat{k})}{\sqrt{1^2 + 3^2 + 5^2}} = \frac{5 - 3 - 15}{\sqrt{35}}$$

$$\Rightarrow \frac{-13}{\sqrt{35}}$$

Ans. (4)

64. Let $\vec{a} = 2\hat{i} - 7\hat{j} + 5\hat{k}$, $\vec{b} = \hat{i} + \hat{k}$ and $\vec{c} = \hat{i} + 2\hat{j} - 3\hat{k}$ be three given vectors. If \vec{r} is a vector such that $\vec{r} \times \vec{a} = \vec{c} \times \vec{a}$ and $\vec{r} \cdot \vec{b} = 0$, then $|\vec{r}|$ is equal to :

- (1) $\frac{11}{5}\sqrt{2}$ (2) $\frac{\sqrt{914}}{7}$ (3) $\frac{11}{7}\sqrt{2}$ (4) $\frac{11}{7}$

Sol. 3

$$\vec{r} \times \vec{a} = \vec{c} \times \vec{a}$$

$$\Rightarrow (\vec{r} - \vec{c}) \times \vec{a} = \vec{0} \Rightarrow \vec{r} - \vec{c} = \lambda \vec{a} \text{ (}\vec{r} - \vec{c} \text{ \& } \vec{a} \text{ are parallel)}$$

$$\Rightarrow \vec{r} = \vec{c} + \lambda \vec{a}$$

$$\Rightarrow \vec{r} \cdot \vec{b} = \vec{c} \cdot \vec{b} + \lambda \vec{a} \cdot \vec{b}$$

$$0 = (1 - 3) + \lambda(2 + 5) \Rightarrow \lambda = \frac{2}{7}$$

Hence, $\vec{r} = \vec{c} + \frac{2\vec{a}}{7}$

$$\vec{r} \Rightarrow \frac{11}{7}\hat{i} - \frac{11}{7}\hat{k}$$

$$|\vec{r}| = \sqrt{\left(\frac{11}{7}\right)^2 + \left(-\frac{11}{7}\right)^2} \Rightarrow r = \frac{11\sqrt{2}}{7}$$

65. Let $f: \mathbb{R} - \{0, 1\} \rightarrow \mathbb{R}$ be a function such that $f(x) + f\left(\frac{1}{1-x}\right) = 1 + x$. Then $f(2)$ is equal to

- (1) $\frac{9}{2}$ (2) $\frac{7}{4}$ (3) $\frac{9}{4}$ (4) $\frac{7}{3}$

Sol. 3

For $x = 2, \Rightarrow f(2) + f(-1) = 3$ (1)

For $x = \frac{1}{2} \Rightarrow f\left(\frac{1}{2}\right) + f(-1) = \frac{3}{2}$ (2)

For $x = -1 \Rightarrow f(-1) + f\left(\frac{1}{2}\right) = 0$ (3)

$$(2) - (3) \Rightarrow f(2) - f(-1) = \frac{3}{2} \quad \dots\dots\dots (4)$$

$$(1) + (4) \Rightarrow 2f(2) = \frac{9}{2} \Rightarrow f(2) = \frac{9}{4}$$

Ans. 3

66. Let $P(S)$ denote the power set of $S = \{1, 2, 3, \dots, 10\}$. Define the relations R_1 and R_2 on $P(S)$ as $A R_1 B$ if $(A \cap B^c) \cup (B \cap A^c) = \emptyset$ and $A R_2 B$ if $A \cup B^c = B \cup A^c, \forall A, B \in P(S)$. Then :

- (1) only R_1 is an equivalence relation (2) only R_2 is an equivalence relation
 (3) both R_1 and R_2 are equivalence relations (4) both R_1 and R_2 are not equivalence relations

Sol. 3

$$S = \{1, 2, 3, \dots, 10\}$$

$P(S)$ = power set of S

$$A R_1 B \Rightarrow (A \cap \bar{B}) \cup (\bar{A} \cap B) = \phi$$

R_1 is reflexive, symmetric

For transitive

$$(A \cap \bar{B}) \cup (\bar{A} \cap B) = \phi; \{a\} = \phi = \{b\} \Rightarrow A = B$$

$$(B \cap \bar{C}) \cup (\bar{B} \cap C) = \phi \therefore B = C$$

$\therefore A = C$ equivalence

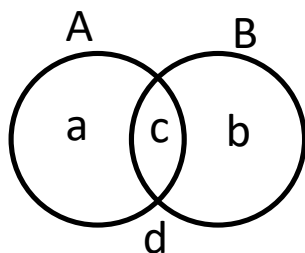

$$R_2 \equiv A \cup \bar{B} = \bar{A} \cup B$$

$R_2 \rightarrow$ reflexive, symmetric

for transitive

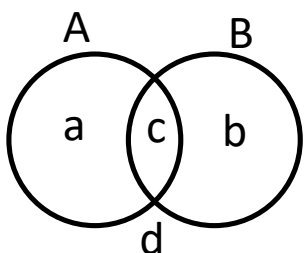

$$A \cup \bar{B} = \bar{A} \cup B \Rightarrow \{a, c, d\} = \{b, c, d\}$$

$$\{a\} = \{b\} \therefore A = B$$

$$B \cup \bar{C} = \bar{B} \cup C \Rightarrow B = C$$

$\therefore A = C \therefore A \cup \bar{C} = \bar{A} \cup C \therefore$ Equivalence

67. The area of the region given by $\{(x, y) : xy \leq 8, 1 \leq y \leq x^2\}$ is :

- (1) $16\log_e 2 + \frac{7}{3}$ (2) $16\log_e 2 - \frac{14}{3}$ (3) $8\log_e 2 - \frac{13}{3}$ (4) $8\log_e 2 + \frac{7}{6}$

Sol. 2

$$A = \int_1^4 \left(\frac{8}{y} - \sqrt{y} \right) dy$$

$$A = 8[\ln y]_1^4 - \frac{2}{3} \left(y^{\frac{3}{2}} \right)_1^4$$

$$\Rightarrow 8\ln 4 - \frac{2}{3} (4^{3/2} - 1)$$

$$\Rightarrow 8\ln 4 - \frac{2}{3} (8 - 1)$$

$$\Rightarrow 16\ln 2 - \frac{14}{3}$$

Ans. (2)

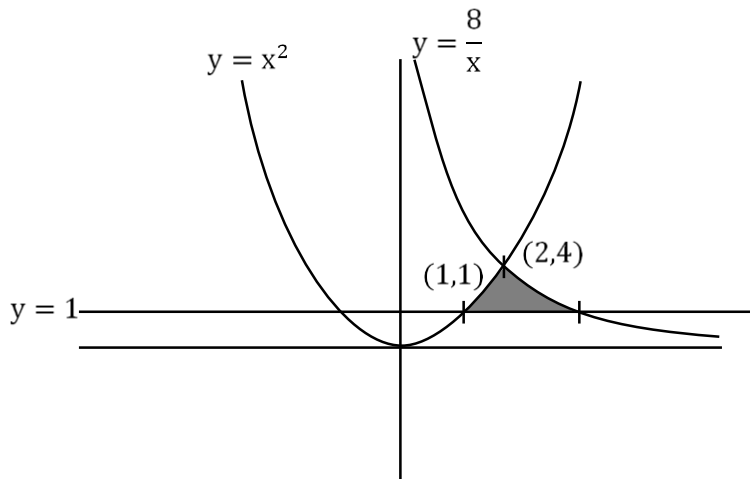

68. If $A = \frac{1}{2} \begin{bmatrix} 1 & \sqrt{3} \\ -\sqrt{3} & 1 \end{bmatrix}$, then :

- (1) $A^{30} + A^{25} + A = I$ (2) $A^{30} = A^{25}$ (3) $A^{30} + A^{25} - A = I$ (4) $A^{30} - A^{25} = 2I$

Sol. 3

$$4 = \frac{1}{2} \begin{bmatrix} 1 & f_3 \\ -f_3 & 1 \end{bmatrix} = \begin{bmatrix} \frac{1}{2} & \frac{f_3}{2} \\ -\frac{f_3}{2} & \frac{1}{2} \end{bmatrix}$$

$$|4 - \lambda| = 0$$

$$\begin{vmatrix} \frac{1}{2} - \lambda & \frac{f_3}{2} \\ -\frac{f_3}{2} & \frac{1}{2} - \lambda \end{vmatrix} = 0 \Rightarrow \lambda^2 + \frac{1}{4} - \lambda + \frac{3}{4} = 0$$

$$\lambda^2 - \lambda + 1 = 0 \Rightarrow A^2 - A + 1 = 0$$

$$\Rightarrow A^3 - A^2 + A = 0$$

$$\text{and } A^4 = (A - I)^2 \Rightarrow A^4 = A^2 + I - 2A$$

$$\Rightarrow A^4 = A - I + I - 2A = -A$$

$$\boxed{A^4 = -A}$$

$$\Rightarrow A^{30} = (A^4)^7 A^2 = -A^4 = -(A^4)A = -A^3 = A - A^2$$

$$A^{25} = (A^4)^6 A = A^6 A = A^7 = A^4 A^3 = -AA^3 = -A^4 = A$$

Put these values on all options, we, get,

$$\Rightarrow A^{30} + A^{25} - A = I$$

So, option (3) is correct.

69. Which of the following statements is a tautology ?

(1) $p \vee (p \wedge q)$

(2) $(p \wedge (p \rightarrow q)) \rightarrow \sim q$

(3) $(p \wedge q) \rightarrow (\sim(p) \rightarrow q)$

(4) $p \rightarrow (p \wedge (p \rightarrow q))$

Sol. 3

(i) $p \rightarrow (p \wedge (p \rightarrow q))$

$(\sim p) \vee (p \wedge (\sim p \vee q))$

$(\sim p) \vee (p \vee (p \wedge q))$

$\sim p \vee (p \wedge q) = (\sim p \vee p) \wedge (\sim p \vee q)$

$= \sim p \vee q$

(ii) $(p \wedge q) \rightarrow (\sim p \rightarrow q)$

$\sim(p \wedge q) \vee (p \vee q) = t$

$\{a, b, d\} \vee \{a, b, c\} = V$

Tautology

(iii) $(p \wedge (p \rightarrow q)) \rightarrow \sim q$

$\sim(p \wedge (\sim p \vee q)) \vee \sim q = \sim(p \wedge q) \vee \sim q = \sim p \vee \sim q$

Not tautology

(iv) $p \vee (p \wedge q) = p$

Not tautology.

So, option (2) is correct.

70. The sum of the absolute maximum and minimum values of the function $f(x) = |x^2 - 5x + 6| - 3x + 2$ in the interval $[-1, 3]$ is equal to :

- (1) 12 (2) 13 (3) 10 (4) 24

Sol. 4

$$f(x) = \begin{cases} x^2 - 5x + 6 - 3x + 2 & .x \in (-\infty, 2) \cup [2, \infty) \\ -(x^2 - 5x + 6) - 3x - 2 & .x \in [2, 3] \end{cases}$$

$$f(x) = \begin{cases} x^2 - 8x + 8 & .x \in (-\infty, 2) \cup [3, \infty) \\ -x^2 + 2x - 4 & .x \in [2, 3] \end{cases}$$

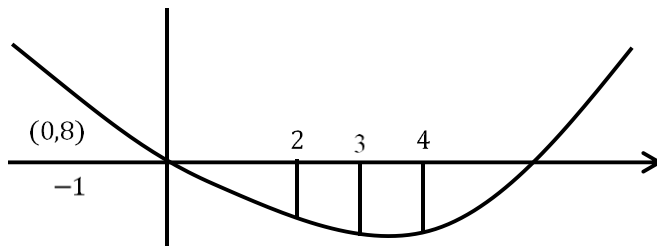

Absolute maximum $= |f(-1)| = |(-1)^2 - 8(-1) + 8| = 17$

Absolute minimum $= |f(3)| = 7$

Sum $= 17 + 7 = 24$

71. Let the plane P pass through the intersection of the planes $2x + 3y - z = 2$ and $x + 2y + 3z = 6$ and be perpendicular to the plane $2x + y - z = 0$. If d is the distance of P from the point $(-7, 1, 1)$ then d^2 is equal to :

- (1) $\frac{250}{83}$ (2) $\frac{250}{82}$ (3) $\frac{15}{53}$ (4) $\frac{25}{83}$

Sol. 1

Plane P, is passing through intersection of the two planes, so,

$$2x + 3y - z - 2 + \lambda(x + 2y + 3z - 6) = 0$$

$$x(2 + \lambda) + y(3 + 2\lambda) + z(3\lambda - 1) - 2 - 6\lambda = 0$$

It is perpendicular with plane, $2x + y - z = 0$

$$\text{So, } (2 + \lambda)2 + (3 + 2\lambda)1 + (3\lambda - 1)(-1) = 0$$

$$\boxed{\lambda = -8}$$

So, plane $p_1 - 6x - 13y - 25z + 46 = 0$

distance of plane p from the point $(-7,1,1)$

$$d = \frac{|+42 - 13 - 25 + 46|}{\sqrt{36 + 169 + 625}} = \frac{50}{\sqrt{830}} =$$

$$d^2 = \frac{2500}{830} = \frac{250}{83}$$

Ans. (1)

72. The number of integral values of k , for which one root of the equation $2x^2 - 8x + k = 0$ lies in the interval $(1,2)$ and its other root lies in the interval $(2,3)$, is :

- (A) 3 (2) 0 (3) 2 (4) 1

Sol. 4

$$\Rightarrow f(1) \cdot f(2) < 0$$

$$(k-6)(k-8) < 0$$

$$\text{Also, } f(2) \cdot f(3) < 0$$

$$(k-8)(k-6) < 0$$

$k \in (6,8) \Rightarrow$ Integral value of k is 7. Ans: (4)

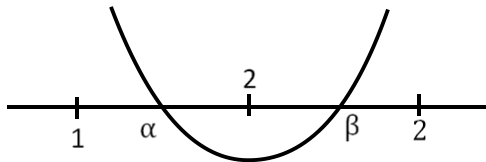

73. Let $P(x_0, y_0)$ be the point on the hyperbola $3x^2 - 4y^2 = 36$, which is nearest to the line $3x + 2y = 1$.

Then $\sqrt{2}(y_0 - x_0)$ is equal to :

- (A) -9 (2) -3 (3) 3 (4) 9

Sol. 1

$$3x^2 - 4y^2 = 36 \quad 3x + 2y = 1$$

$$m = -\frac{3}{2}$$

$$m = +\frac{3 \sec \theta}{\sqrt{12} \cdot \tan \theta}$$

$$\Rightarrow \frac{3}{\sqrt{12}} \times \frac{1}{\sin \theta} = \frac{-3}{2}$$

$$\sin \theta = -\frac{1}{\sqrt{3}}$$

$$(\sqrt{12} \cdot \sec \theta, 3 \tan \theta)$$

$$\left(\sqrt{12} \cdot \frac{\sqrt{3}}{\sqrt{2}}, -3 \times \frac{1}{\sqrt{2}}\right) \Rightarrow \left(\frac{6}{\sqrt{2}}, \frac{-3}{\sqrt{2}}\right) = (x_0, y_0)$$

$$\Rightarrow \sqrt{2}(y_0 - x_0) = \sqrt{2}\left(\frac{-3}{\sqrt{2}} - \frac{6}{\sqrt{2}}\right) = -9$$

74. Two dice are thrown independently. Let A be the event that the number appeared on the 1st die is less than the number appeared on the 2nd die, B be the event that the number appeared on the 1st die is even and that on the second die is odd, and C be the event that the number appeared on the 1st die is odd and that on the 2nd is even. Then :

- (1) the number of favourable cases of the events A, B and C are 15, 6 and 6 respectively
- (2) the number of favourable cases of the event $(A \cup B) \cap C$ is 6
- (3) B and C are independent
- (4) A and B are mutually exclusive

Sol. 2

$$A = \{(1,2), (1,3), (1,4), (1,5), (1,6), (2,3), (2,4), (2,5), (2,6), (3,4), (3,5), (3,6), (4,5), (4,6), (5,6)\}$$

$$n(A) = 15$$

$$B = \{(2,1), (2,3), (2,5), (4,1), (4,3), (4,5), (6,1), (6,3), (6,5)\}$$

$$n(B) = 9$$

$$C = \{(1,2), (1,4), (1,6), (3,2), (3,4), (3,6), (5,2), (5,4), (5,6)\}$$

$$n(C) = 9$$

$$((A \cup B) \cap C) = \{(1,2), (1,4), (1,6), (3,4), (3,6), (5,6)\}$$

$$\Rightarrow n((A \cup B) \cap C) = 6$$

75. If $y(x) = x^x, x > 0$, then $y''(2) - 2y'(2)$ is equal to :

- (1) $4 \log_e 2 + 2$
- (2) $8 \log_e 2 - 2$
- (3) $4(\log_e 2)^2 + 2$
- (4) $4(\log_e 2)^2 - 2$

Sol. 4

$$y = x^x$$

$$\ln y = x \ln x$$

$$\frac{1}{y} y' = 1 + \ln x$$

$$y' = y(1 + \ln x)$$

$$y' = x^x(1 + \ln x)$$

$$\text{At } x = 2 \text{ we have } y = 4$$

$$\text{So } y'(2) = 4(1 + \ln 2) \dots \dots \dots (2)$$

$$\text{Andy}'' = y'(1 + \ln x) + \frac{y}{x}$$

$$y'(2) = y'(1 + \ln 2) + 2$$

$$y'(2) = y'(2) = y'(\ln 2) + 2$$

$$y''(2) = 2y'(2) = (\ln 2 - 1)y'(2) + 2$$

$$= 4(\ln 2 - 1)(\ln 2 + 2) + 2$$

$$= 4(\ln 2)^2 - 2$$

76. Let $S = \left\{ x \in \mathbb{R} : 0 < x < 1 \text{ and } 2 \tan^{-1} \left(\frac{1-x}{1+x} \right) = \cos^{-1} \left(\frac{1-x^2}{1+x^2} \right) \right\}$.

If $n(S)$ denotes the number of elements in S then :

(1) $n(S) = 2$ and only one element in S is less than $\frac{1}{2}$.

(2) $n(S) = 1$ and the element in S is more than $\frac{1}{2}$.

(3) $n(S) = 0$

(4) $n(S) = 1$ and the element in S is less than $\frac{1}{2}$.

Sol. 1

Put $x = \tan \theta$ $\theta \in \left(0, \frac{\pi}{4} \right)$

$$2 \tan^{-1} \left(\frac{1 - \tan \theta}{1 + \tan \theta} \right) = \cos^{-1} \left(\frac{1 - \tan^2 \theta}{1 + \tan^2 \theta} \right)$$

$$2 \tan^{-1} \left[\tan \left(\frac{\pi}{4} - \theta \right) \right] = \cos^{-1} [\cos(2\theta)]$$

$$\Rightarrow 2 \left(\frac{\pi}{4} - \theta \right) = 2\theta \Rightarrow \theta = \frac{\pi}{8}$$

$$\Rightarrow x = \tan \frac{\pi}{8} = \sqrt{2} - 1 \simeq 0.414$$

77. The value of the integral $\int_{-\frac{\pi}{4}}^{\frac{\pi}{4}} \frac{x + \frac{\pi}{4}}{2 - \cos 2x} dx$ is :

(1) $\frac{\pi^2}{12\sqrt{3}}$

(2) $\frac{\pi^2}{6\sqrt{3}}$

(3) $\frac{\pi^2}{6}$

(4) $\frac{\pi^2}{3\sqrt{3}}$

Sol. 2

$$\begin{aligned}
I &= \int_{-\frac{\pi}{4}}^{\frac{\pi}{4}} \frac{x dx}{2 - \cos 2x} + \frac{\pi}{4} \int_{-\frac{\pi}{4}}^{\frac{\pi}{4}} \frac{x dx}{2 - \cos 2x} \\
&= 0 + \frac{\pi}{4} \cdot 2 \int_0^{\frac{\pi}{4}} \frac{x dx}{2 - \cos 2x} \\
&= \frac{\pi}{2} \int_0^{\frac{\pi}{4}} \frac{\sec^2 x dx}{1 + 3 \tan^2 x}
\end{aligned}$$

Now,

$$\begin{aligned}
\tan x &= t \\
&= \frac{\pi}{2} \int_0^1 \frac{dt}{1 + 3t^2} \\
&= \frac{\pi}{2} \left[\frac{\tan^{-1}(\sqrt{3}t)}{\sqrt{3}} \right]_0^1 \\
&= \frac{\pi}{2\sqrt{3}} \left(\frac{\pi}{3} \right) = \frac{\pi^2}{6\sqrt{3}}
\end{aligned}$$

78. For the system of linear equations $\alpha x + y + z = 1$, $x + \alpha y + z = 1$, $x + y + \alpha z = \beta$, which one of the following statements is NOT correct ?

- (1) It has infinitely many solutions if $\alpha = 2$ and $\beta = -1$
- (2) It has no solution if $\alpha = -2$ and $\beta = 1$
- (3) $x + y + z = \frac{3}{4}$ if $\alpha = 2$ and $\beta = 1$
- (4) It has infinitely many solutions if $\alpha = 1$ and $\beta = 1$

Sol. 1

$$\begin{vmatrix} \alpha & 1 & 1 \\ 1 & \alpha & 1 \\ 1 & 1 & \alpha \end{vmatrix} = 0$$

$$\alpha(\alpha^2 - 1) - 1(\alpha - 1) + 1(1 - \alpha) = 0$$

$$\alpha^3 - 3\alpha + 2 = 0$$

$$\alpha^2(\alpha - 1) + \alpha(\alpha - 1) - 2(\alpha - 1) = 0$$

$$(\alpha - 1)(\alpha^2 + \alpha - 2) = 0$$

$$\alpha = 1, \alpha = -2, 1$$

For $\alpha = 1, \beta = 1$

$$\left. \begin{array}{l} x + y + z = 1 \\ x + y + z = \beta \end{array} \right\} \text{infinite solution}$$

For $\alpha=2, \beta=1$

$$\Delta = 4$$

$$\Delta_1 = \begin{vmatrix} 1 & 1 & 1 \\ 1 & 2 & 1 \\ 1 & 1 & 2 \end{vmatrix} = 3 - 1 - 1 \Rightarrow x = \frac{1}{4}$$

$$\Delta_2 = \begin{vmatrix} 2 & 1 & 1 \\ 1 & 1 & 1 \\ 1 & 1 & 2 \end{vmatrix} = 2 - 1 = 1 \Rightarrow y = \frac{1}{4}$$

$$\Delta_3 = \begin{vmatrix} 2 & 1 & 1 \\ 1 & 2 & 1 \\ 1 & 1 & 1 \end{vmatrix} = 2 - 1 = 1 \Rightarrow z = \frac{1}{4}$$

For $\alpha=2 \Rightarrow$ unique solution

- 79.** Let $9 = x_1 < x_2 < \dots < x_7, \dots, x_7$ be in an A.P. with common difference d . If the standard deviation of $x_1 \cdot x_2, \dots, x_7$ is 4 and mean is \bar{x} , then $\bar{x} + x_6$ is equal to :

(1) $2\left(9 + \frac{8}{\sqrt{7}}\right)$ (2) $18\left(1 + \frac{1}{\sqrt{3}}\right)$ (3) 25 (4) 34

Sol. 4

$$\text{Mean} \Rightarrow \bar{x} = \frac{\sum_{i=1}^7 x_i}{7} = \frac{\frac{7}{2}[2a+6d]}{7} = a+3d = x_4$$

$$\text{Variance} = \frac{\sum_{i=1}^7 (x_i - \bar{x})^2}{7} = (4)^2 \Rightarrow \frac{\sum_{i=1}^7 (x_i - x_4)^2}{7} = 16$$

$$\Rightarrow \frac{(3d)^2 + (2d)^2 + d^2 + 0 + d^2 + (2d)^2 + (3d)^2}{7} = 16$$

$$= 4d^2 = 16 \Rightarrow d = 2$$

$$\Rightarrow \bar{x} = 9 + 3(2) = 15$$

$$\&x_6 = a + 5d = 9 + 5(2) = 19 \Rightarrow \bar{x} + x_6 = 34$$

- 80.** Let a, b be two real numbers such that $ab < 0$. IF the complex number $\frac{1+ai}{b+i}$ is of unit modulus and a

+ ib lies on the circle $|z-1| = |2z|$, then a possible value of $\frac{1+[a]}{4b}$, where $[t]$ is greatest integer function,

is :

(1) $-\frac{1}{2}$ (2) -1 (3) 1 (4) $\frac{1}{2}$

Sol. Bonus

$$ab < 0 \left| \frac{1+ai}{b+i} \right| = 1$$

$$|1+ia| = |b+i|$$

$$a^2 + 1 = b^2 + 1 \Rightarrow a = \pm b \Rightarrow b = -a \text{ as } ab < 0$$

$$(a,b) \text{ lies on } |z-1| = |2z|$$

$$|a+ib-1| = 2|a+ib|$$

$$(a-1)^2 + b^2 = 4(a^2 + b^2)$$

$$(a-1)^2 = a^2 = 4(2a^2)$$

$$1-2a = 6a^2 \Rightarrow 6a^2 + 2a - 1 = 0$$

$$a = \frac{-2 \pm \sqrt{28}}{12} = \frac{-1 \pm \sqrt{7}}{6}$$

$$a = \frac{\sqrt{7}-1}{6} \& b = \frac{1-\sqrt{7}}{6}$$

$$[a] = 0$$

$$\therefore \frac{1+[a]}{4b} = \frac{6}{4(1-\sqrt{7})} = -\left(\frac{1+\sqrt{7}}{4}\right)$$

$$\text{or } [a] = 0$$

$$\text{Similarly it is not matching with } a = \frac{-1-\sqrt{7}}{6}$$

No answer is matching.

SECTION - B

- 81.** Let $\alpha x + \beta y + \gamma z = 1$ be the equation of a plane through the point $(3, -2, 5)$ and perpendicular to the line joining the points $(1, 2, 3)$ and $(-2, 3, 5)$. Then the value of $\alpha\beta\gamma$ is equal to

Sol. 6

Plane is perp. To the line joining the

$(1, 2, 3)$ & $(-2, 3, 5)$

So, line will be along normal of plane.

$$\vec{n} = (3, -1, -2) \text{ or } (-3, 1, 2)$$

Compare it with eq. of plane, $\alpha x + \beta y + \gamma z = 1$

$$\alpha = 3, \beta = -1, \gamma = -2 \text{ or } \alpha = -3, \beta = 1, \gamma = 2$$

So, $\alpha\beta\gamma = 6$ (in both cases)

Ans. 6

82. If the term without x in the expansion of $\left(x^{\frac{2}{3}} + \frac{a}{x^3}\right)^{22}$ is 7315, then $|\alpha|$ is equal to

Sol. 1

$$\Rightarrow \text{General Term, } T_{r+1} = {}^{22}C_r \left(x^{\frac{2}{3}}\right)^{22-r} \cdot \left(\frac{\alpha}{x^3}\right)^r$$

$$T_{r+1} = {}^{22}C_r \cdot x^{\frac{2(22-r)}{3}-3r} \alpha^r$$

For term independent of x ,

$$\frac{2(22-r)}{3} - 3r = 0$$

$$44 - 2r = 9r \Rightarrow 11r = 44$$

$$T_{4+1} = {}^{22}C_4 \cdot \alpha^4 = 7315$$

$$7315 \cdot \alpha^4 = 7315 \Rightarrow \alpha^4 = 1 \Rightarrow |\alpha| = 1$$

Ans. 1

83. If the x - intercept of a focal chord of the parabola $y^2 = 8x + 4y + 4$ is 3, then the length of this chord is equal to

Sol. 16

$$y^2 = 8x + 4y + 4$$

$$(y-2)^2 = 8(x+1)$$

$$y^2 = 4ax$$

$$a=2, X=x+1, Y=y-2$$

focus (1,2)

$$y-2 = m(x-1)$$

Put (3, 0) in the above line

$$m = -1$$

Length of focal chord = 16

84. Let the sixth term in the binomial expansion of $\left(\sqrt{\log_2(10-3^3)} + \sqrt[5]{2^{x \log_2 3}}\right)^m$, in the increasing powers of $2^{(x-2)\log_2 3}$, be 21. If the binomial coefficients of the second, third and fourth terms in the expansion are respectively the first, third and fifth terms of A.P., then the sum of the squares of all possible values of x is

Sol. 4

$$\Rightarrow \text{Sixth Term, } T_{5+1} = {}^m C_5 (10-3^x)^{\frac{m-5}{2}} 3^{x-2} = 21$$

$$\text{So, } 2 {}^m C_2 = {}^m C_1 + {}^m C_3$$

$$2 \frac{m(m-1)}{2} = m + \frac{m(m-1)(m-2)}{6}$$

$$\Rightarrow m = 2, 7 \text{ (But } m = 2 \text{ is inadmissible)}$$

$$\Rightarrow m = 7$$

$$\text{Now, } T_{5+1} = {}^7 C_5 (10-3^x)^{\frac{7-5}{2}} 3^{x-2} = 21$$

$$\Rightarrow \frac{10 \cdot 3^x - (3^x)^2}{3^2} = 1$$

$$(3^x)^2 - 10 \cdot 3^x + 9 = 0$$

$$3^x = 9, 1$$

$$\Rightarrow x = 0, 2$$

$$\text{Sum of squares of values of } x = 0^2 + 2^2 = 4$$

Ans. (4)

- 85.** The point of intersection C of the plane $8x + y + 2z = 0$ and the line joining the point $A(-3, -61)$ and $B(2, -4, -3)$ divides the line segment AB internally in the ratio k:1. If a, b, c ($|a|, |b|, |c|$) are coprime are the direction ratios of the perpendicular from the point C on the line $\frac{1-x}{1} = \frac{y+4}{2} = \frac{z+2}{3}$, then $|a + b + c|$ is equal to

Sol. 10

$$\text{Plane : } 8x + y + 2z = 0$$

$$\text{Given line AB : } \frac{x-2}{5} = \frac{y-4}{10} = \frac{z+3}{-4} = \lambda$$

$$\text{Any point on line } (5\lambda + 2, 10\lambda + 4, -4\lambda - 3)$$

Point of intersection of line and plane

$$8(5\lambda + 2) + 10\lambda + 4 - 8\lambda - 6 = 0$$

$$\lambda = -\frac{1}{3}$$

$$C \left(\frac{1}{3}, \frac{2}{3}, -\frac{5}{3} \right)$$

$$L : \frac{x-1}{-1} = \frac{y+4}{2} = \frac{z+2}{3} = \mu$$

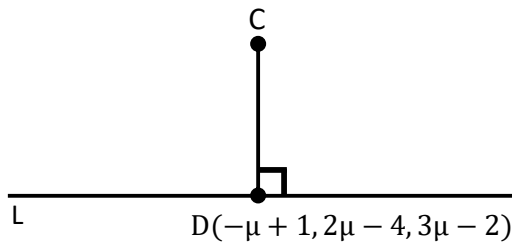

$$\overline{CD} = \left(-\mu + \frac{2}{3}\right)\hat{i} + \left(2\mu - \frac{14}{3}\right)\hat{j} + \left(3\mu - \frac{1}{3}\right)\hat{k}$$

$$\left(-\mu + \frac{2}{3}\right)(-1) + \left(2\mu - \frac{14}{3}\right)2 + \left(3\mu - \frac{1}{3}\right)3 = 0$$

$$\mu = \frac{11}{14}$$

$$\overline{CD} = \frac{-5}{42}, \frac{-130}{42}, \frac{85}{42}$$

Direction ratio $\rightarrow (-1, -26, 17)$

$$|a+b+c|=10$$

86. The line $x = 8$ is the directrix of the ellipse $E: \frac{x^2}{a^2} + \frac{y^2}{b^2} = 1$ with the corresponding focus $(2,0)$.

If the tangent to E at the point P in the first quadrant passes through the point $(0, 4\sqrt{3})$ and intersects the x -axis at Q then $(3PQ)^2$ equal to

Sol. 39

$$\frac{a}{e} = 8 \quad \dots(1)$$

$$ae = 2 \quad \dots(2)$$

$$8e = \frac{2}{e}$$

$$e^2 = \frac{1}{4} \Rightarrow e = \frac{1}{2}$$

$$a = 4$$

$$b^2 = a^2(1 - e^2)$$

$$= 16\left(\frac{3}{4}\right) = 12$$

$$\frac{x \cos \theta}{4} + \frac{y \sin \theta}{2\sqrt{3}} = 1$$

$$\sin \theta = \frac{1}{2}$$

$$\theta = 30^\circ$$

$$P(2\sqrt{3}, \sqrt{3})$$

$$Q\left(\frac{8}{\sqrt{3}}, 0\right)$$

$$(3PQ)^2 = 39$$

87. The total number of six digit numbers, formed using the digits 4, 5, 9 only and divisible by 6, is

Sol. 81

We have,

For this, 4 will be fixed as unit place digit

Total number

Case I: 4's \rightarrow 6 times 1

Case II: 4's \rightarrow 4times

$$5's \rightarrow 1times \quad \frac{5!}{3!} = 20$$

9's \rightarrow 1times

Case III: 4's \rightarrow 3times

$$5's \rightarrow 3times \quad \frac{5!}{2!3!} = 10$$

Case IV: 4's \rightarrow 3times

$$9's \rightarrow 3times \quad \frac{5!}{2!3!} = 10$$

Case V: 4's \rightarrow 2times

$$5's \rightarrow 2times \quad \frac{5!}{2!2!} = 30$$

9's \rightarrow 2times

Case VI: 4's \rightarrow 1times

$$5's \rightarrow 1times \quad \frac{5!}{4!} = 5$$

9's \rightarrow 4times

Case VII: 4's \rightarrow 1times

$$5's \rightarrow 4times \quad \frac{5!}{4!} = 5$$

9's \rightarrow 1times

Total numbers = 81

88. Number of integral solutions to the equation $x + y + z = 21$, where $x \geq 1$, $y \geq 3$, $z \geq 4$, is equal to

Sol. 105

$${}^{15}C_2 = \frac{15 \times 14}{2} = 105$$

89. The sum of the common terms of the following three arithmetic progressions.

3, 7, 11, 15,.....,399

2, 5, 8, 11,.....,359 and

2, 7, 12, 17,....., 197

is equal to

Sol. 321

3, 7, 11, 15,....., 399 $d_1 = 4$

2, 5, 8, 11,....., 359 $d_2 = 3$

2, 7, 12, 17,....., 197 $d_3 = 5$

$\text{LCM}(d_1, d_2, d_3) = 60$

Common terms are 47, 107, 167

Sum = 321

90. If $\int \frac{5 \cos^x (1 + \cos x \cos 3x + \cos^2 x + \cos^3 x \cos 3x) dx}{1 + 5^{\cos x}} = \frac{k\pi}{16}$, then k is equal to

Sol. 13

$$I = \int_0^{\pi} \frac{5^{\cos x} (1 + \cos x \cos 3x + \cos^2 x + \cos^3 x \cos 3x)}{1 + 5^{\cos x}} dx$$

$$I = \int_0^{\pi} \frac{5^{-\cos x} (1 + \cos x \cos 3x + \cos^2 x + \cos^3 x \cos 3x)}{1 + 5^{-\cos x}} dx$$

$$2I = \int_0^{\pi} (1 + \cos x \cos 3x + \cos^2 x + \cos^3 x \cos 3x) dx$$

$$2I = 2 \int_0^{\frac{\pi}{2}} (1 + \cos x \cos 3x + \cos^2 x + \cos^3 x \cos 3x) dx$$

$$I = \int_0^{\frac{\pi}{2}} (1 + \sin x (-\sin 3x) + \sin^2 x - \sin^3 x \sin 3x) dx$$

$$2I = \int_0^{\frac{\pi}{2}} (3 + \cos 4x + \cos^3 x \cos 3x - \sin^3 x \sin 3x) dx$$

$$2I = \int_0^{\frac{\pi}{2}} \left(3 + \cos 4x + \left(\frac{\cos 3x + 3 \cos x}{4} \right) \cos 3x - \sin 3x \left(\frac{3 \sin x - \sin 3x}{4} \right) \right) dx$$

$$2I = \int_0^{\frac{\pi}{2}} \left(3 + \cos 4x + \frac{1}{4} + \frac{3}{4} \cos 4x \right) dx$$

$$2I = \frac{13}{4} \times \frac{\pi}{2} + \frac{7}{4} \left(\frac{\sin 4x}{4} \right)_0^{\frac{\pi}{2}} \Rightarrow I = \frac{13\pi}{16}$$