

Physics

SECTION - A

- 1.** A circular loop of radius r is carrying current I A. The ratio of magnetic field at the center of circular loop and at a distance r from the center of the loop on its axis is:

(1) $2\sqrt{2} : 1$ (2) $1 : 3\sqrt{2}$ (3) $1 : \sqrt{2}$ (4) $3\sqrt{2} : 2$

Sol. 1

Magnetic field at centre of coil $B_1 = \frac{\mu_0 I}{2r}$

on the axis at $x = r \Rightarrow B_2 = \frac{\mu_0 I r^2}{2(r^2 + x^2)^{3/2}}$

$$B_2 = \frac{\mu_0 I r^2}{2(r^2 + r^2)^{3/2}}$$

$$B_2 = \frac{\mu_0 I}{2(2\sqrt{2} r)}$$

$$\frac{B_1}{B_2} = 2\sqrt{2}$$

- 2.** The weight of a body at the surface of earth is 18 N. The weight of the body at an altitude of 3200 km above the earth's surface is (given, radius of earth $R_e = 6400$ km):

(1) 8 N (2) 4.9 N (3) 9.8 N (4) 19.6 N

Sol. 1

Weight on earth surface $W = mg = 18$ N

Above earth surface $\Rightarrow W_2 = m \frac{GM}{(R+h)^2}$

$h = 3200$ km = $R/2$

$$W_2 = m \frac{GM}{\left(\frac{3R}{2}\right)^2} \Rightarrow W_2 = \frac{4}{9} mg$$

$$W_2 = \frac{4}{9} \times 18 \Rightarrow W_2 = 8$$
 N

- 3.** Two long straight wires P and Q carrying equal current 10 A each were kept parallel to each other at 5 cm distance. Magnitude of magnetic force experienced by 10 cm length of wire P is F_1 - If distance between wires is halved and currents on them are doubled, force F_2 on 10 cm length of wire P will be:

(1) $\frac{F_1}{8}$ (2) $8 F_1$ (3) $10 F_1$ (4) $\frac{F_1}{10}$

Sol. 2

$$F = \frac{\mu_0 I_1 I_2}{2\pi r} \Rightarrow F = \frac{\mu_0 I^2 \ell}{2\pi r}$$

$\ell = 10$ cm (Both) $\Rightarrow F \propto \frac{I^2}{r}$

$$\frac{F_1}{F_2} = \left(\frac{I}{2I}\right)^2 \left(\frac{5/2}{5}\right) \Rightarrow \frac{F_1}{F_2} = \frac{1}{8} \Rightarrow F_2 = 8F_1$$

4. Given below are two statements :

Statement I : The temperature of a gas is -73°C . When the gas is heated to 527°C , the root mean square speed of the molecules is doubled.

Statement II : The product of pressure and volume of an ideal gas will be equal to translational kinetic energy of the molecules.

In the light of the above statements, choose the correct answer from the options given below:

- (1) Statement I is false but Statement II is true
- (2) Both Statement I and Statement II are false
- (3) Statement I is true but Statement II is false
- (4) Both Statement I and Statement II are true

Sol. 3

Statements-1

$$v_{\text{rms}} \propto \sqrt{T} \Rightarrow v_{\text{rms}_1} \propto \sqrt{273 - 73}$$

$$v_{\text{rms}_2} \propto \sqrt{273 + 527}$$

$$\frac{v_{\text{rms}_1}}{v_{\text{rms}_2}} = \sqrt{\frac{200}{800}} \Rightarrow v_{\text{rms}_2} = 2v_{\text{rms}_1} \quad (\text{True})$$

Statements-2

$$\text{Translation K.E.} = \frac{3}{2}nRT = \frac{3}{2}PV \quad (\text{False})$$

5. The maximum vertical height to which a man can throw a ball is 136 m. The maximum horizontal distance upto which he can throw the same ball is:

- (1) 272 m
- (2) 68 m
- (3) 192 m
- (4) 136 m

Sol. 1

$$\text{Max vertical height } H = \frac{v^2}{2g} = 136 \text{ m}$$

$$\text{Max horizontal distance } R = \frac{v^2}{g} \Rightarrow R = 2 \times 136 = 272 \text{ m}$$

6. Given below are two statements :

Statement I : If the Brewster's angle for the light propagating from air to glass is θ_B , then the Brewster's angle for the light propagating from glass to air is $\frac{\pi}{2} - \theta_B$

Statement II : The Brewster's angle for the light propagating from glass to air is $\tan^{-1}(\mu_g)$ where μ_g is the refractive index of glass.

In the light of the above statements, choose the correct answer from the options given below:

- (1) Both Statement I and Statement II are false
- (2) Statement I is true but Statement II is false
- (3) Statement I is false but Statement II is true
- (4) Both Statement I and Statement II are true

Sol. 2

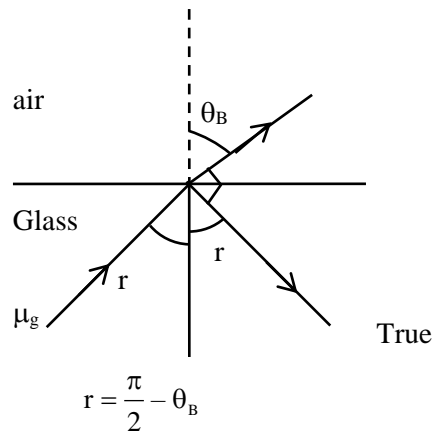
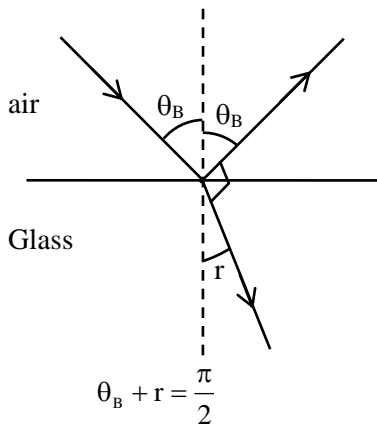

For glass to air

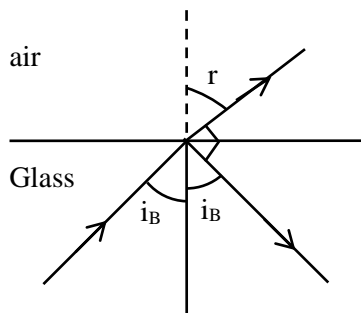

$$\mu_g \sin i_B = 1 \cdot \sin r$$

$$r + i_B = \frac{\pi}{2}$$

$$\mu_g \sin i_B = \cos i_B \Rightarrow \tan i_B = \frac{1}{\mu_g} \Rightarrow i_B = \tan^{-1} \left(\frac{1}{\mu_g} \right)$$

7. A 100 m long wire having cross-sectional area $6.25 \times 10^{-4} \text{ m}^2$ and Young's modulus is 10^{10} Nm^{-2} is subjected to a load of 250 N, then the elongation in the wire will be:

- (1) $4 \times 10^{-3} \text{ m}$ (2) $6.25 \times 10^{-3} \text{ m}$ (3) $6.25 \times 10^{-6} \text{ m}$ (4) $4 \times 10^{-4} \text{ m}$

Sol. 1

$$\text{Stress} = y \text{ strain} \Rightarrow \frac{W}{A} = y \frac{\Delta \ell}{\ell}$$

$$\Delta \ell = \frac{W \ell}{y A} \Rightarrow \Delta \ell = \frac{250 \times 100}{10^{10} \times 6.25 \times 10^{-4}}$$

$$\Delta \ell = 4 \times 10^{-3} \text{ m}$$

8. If two charges q_1 and q_2 are separated with distance 'd' and placed in a medium of dielectric constant K. What will be the equivalent distance between charges in air for the same electrostatic force?

- (1) $2d\sqrt{k}$ (2) $1.5 d\sqrt{k}$ (3) $d\sqrt{k}$ (4) $k\sqrt{d}$

Sol. 3

For same force

$$\frac{q_1 q_2}{4\pi\epsilon_0 k d^2} = \frac{q_1 q_2}{4\pi\epsilon_0 r^2} \Rightarrow r = d\sqrt{K}$$

9. Consider the following radioactive decay process

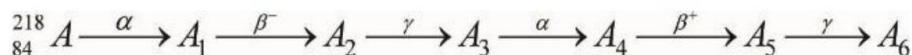

The mass number and the atomic number of A_6 are given by:

- (1) 210 and 84 (2) 210 and 82 (3) 211 and 80 (4) 210 and 80

Sol. 4

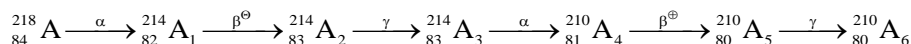

10. From the photoelectric effect experiment, following observations are made. Identify which of these are correct.

- A. The stopping potential depends only on the work function of the metal.
- B. The saturation current increases as the intensity of incident light increases.
- C. The maximum kinetic energy of a photo electron depends on the intensity of the incident light.
- D. Photoelectric effect can be explained using wave theory of light.

Choose the correct answer from the options given below:

- (1) A, C, D only (2) B, C only (3) B only (4) A, B, D only

Sol. 3

$$v_{sp} = \frac{hv - \phi}{e} \quad (v \text{ and } \phi \text{ both})$$

Intensity \uparrow current \uparrow

$$kE_{max} = hv - \phi$$

Photoelectric effect is not explained by wave theory

11. Given below are two statements:

Statement I: An elevator can go up or down with uniform speed when its weight is balanced with the tension of its cable.

Statement II: Force exerted by the floor of an elevator on the foot of a person standing on it is more than his/her weight when the elevator goes down with increasing speed.

In the light of the above statements, choose the correct answer from the options given below:

- (1) Both Statement I and Statement II are true
- (2) Statement I is false but Statement II is true
- (3) Statement I is true but Statement II is false
- (4) Both Statement I and Statement II are false

Sol. 3

Statement-1

When force balance it can move with uniform velocity (Uniform speed) True

Statement-2

Elevator going down with increasing speed means its acceleration is downwards

$$mg - N = ma \text{ (on person)}$$

$$N = mg - ma \text{ (False)}$$

12. 1 g of a liquid is converted to vapour at 3×10^5 Pa pressure. If 10% of the heat supplied is used for increasing the volume by 1600 cm^3 during this phase change, then the increase in internal energy in the process will be:

- (1) 432000 J (2) 4320 J (3) 4800 J (4) 4.32×10^8 J

Sol. 2

10% of $\Delta Q = P\Delta V$ (W/D by gas)

$$\frac{\Delta Q}{10} = 3 \times 10^5 (1600 \times 10^{-6})$$

$$\Delta Q = 4800 \text{ J}$$

Using first law of the thermodynamics

$$\Delta Q = \Delta u + W$$

$$\Delta Q = \Delta u + \frac{\Delta Q}{10} \Rightarrow \Delta u = \frac{9}{10} \Delta Q$$

$$\Delta u = \frac{9}{10} \times 4800 \Rightarrow \Delta u = 4320 \text{ J}$$

13. As shown in the figure, a network of resistors is connected to a battery of 24 V with an internal resistance of 3Ω . The currents through the resistors R_4 and R_5 are I_4 and I_5 respectively. The values of I_4 and I_5 are:

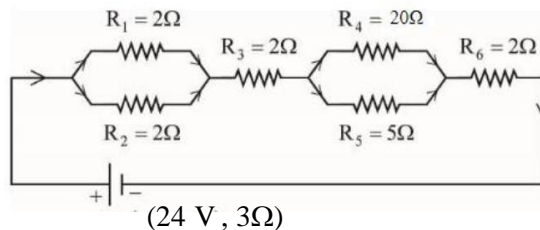

(1) $I_4 = \frac{2}{5}$ A and $I_5 = \frac{8}{5}$ A

(2) $I_4 = \frac{24}{5}$ A and $I_5 = \frac{6}{5}$ A

(3) $I_4 = \frac{8}{5}$ A and $I_5 = \frac{2}{5}$ A

(4) $I_4 = \frac{6}{5}$ A and $I_5 = \frac{24}{5}$ A

Sol. 1

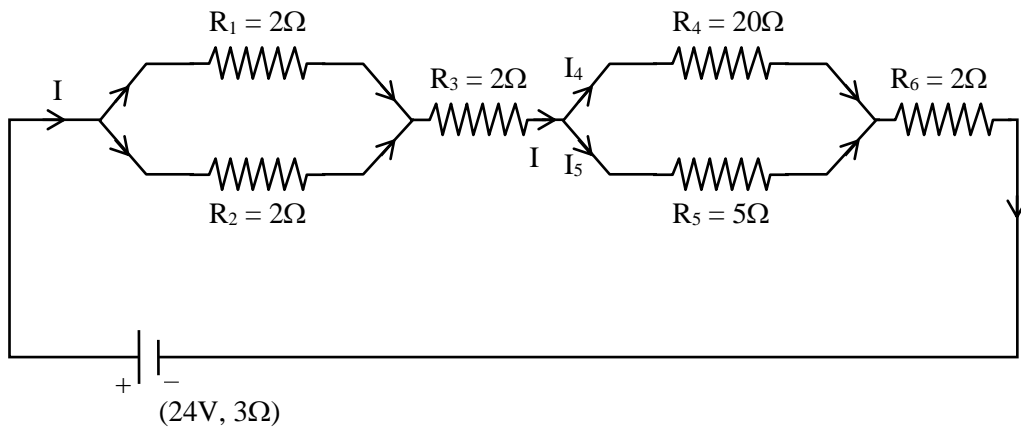

$$R_{eq} = 3 + 1 + 2 + \frac{20 \times 5}{25} + 2 \Rightarrow R_{eq} = 12\Omega$$

$$\text{Current from battery } I = \frac{24}{12} \Rightarrow I = 2A$$

$$I_4 + I_5 = 2A$$

$$I_4(20) = I_5(5) \Rightarrow I_5 = 4I_4 \Rightarrow I_4 = \frac{2}{5}A \quad I_5 = \frac{8}{5}A$$

14. A modulating signal is a square wave, as shown in the figure.

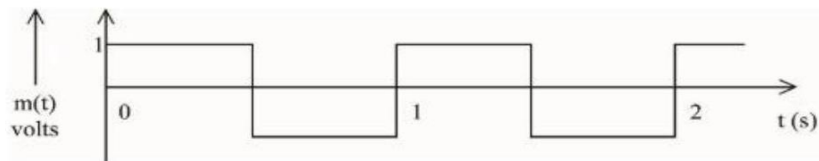

If the carrier wave is given as $c(t) = 2\sin(8\pi t)$ volts, the modulation index is:

- (1) $\frac{1}{4}$ (2) $\frac{1}{2}$ (3) 1 (4) $\frac{1}{3}$

Sol. 2

$$\text{Modulation index } \mu = \frac{A_m}{A_c}$$

$$A_m = 1 \text{ \& } A_c = 2$$

$$\mu = \frac{1}{2}$$

15. A conducting circular loop of radius $\frac{10}{\sqrt{\pi}}$ cm is placed perpendicular to a uniform magnetic field of 0.5 T. The magnetic field is decreased to zero in 0.5 s at a steady rate. The induced emf in the circular loop at 0.25 s is:

- (1) emf = 1mV (2) emf = 5mV (3) emf = 100mV (4) emf = 10mV

Sol. 4

$$\text{emf} = -\frac{d\phi}{dt} \Rightarrow \varepsilon = \frac{-d(BA)}{dt}$$

$$\varepsilon = -A \frac{dB}{dt} \Rightarrow \varepsilon = -\pi R^2 \left(\frac{0-B}{\Delta t} \right)$$

$$\varepsilon = \frac{\pi R^2 B}{\Delta t} \Rightarrow \varepsilon = \frac{\pi \left(\frac{10}{\sqrt{\pi}} \times 10^{-2} \right)^2 \times 0.5}{0.5}$$

$$\varepsilon = 10^{-2} \text{ volt} = 10 \text{ m volt}$$

16. In \vec{E} and \vec{K} represent electric field and propagation vectors of the EM waves in vacuum, then magnetic field vector is given by :

(ω - angular frequency):

(1) $\omega(\vec{E} \times \vec{K})$

(2) $\omega(\vec{K} \times \vec{E})$

(3) $\vec{K} \times \vec{E}$

(4) $\frac{1}{\omega}(\vec{K} \times \vec{E})$

Sol. 4

$$\vec{E} \text{ \& } \vec{K} = \frac{W}{C} \hat{L}$$

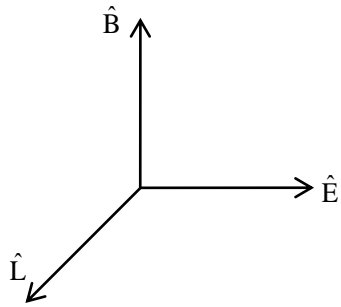

$$\hat{B} = \hat{L} \times \hat{E}$$

$$\vec{B} = B \hat{B} \left\{ \frac{E}{B} = C \right\}$$

$$\vec{B} = \frac{E}{C} (\hat{L} \times \hat{E})$$

$$\vec{B} = \frac{\omega}{C} \left(\frac{\hat{L} \times E \hat{E}}{\omega} \right) \Rightarrow \vec{B} = \frac{\vec{K} \times \vec{E}}{\omega}$$

Sol. 2

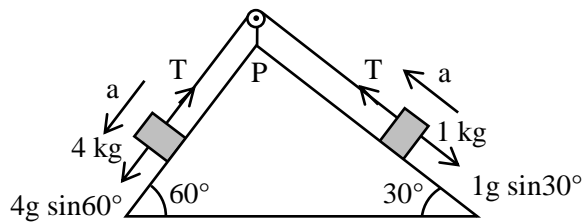

$$4g \frac{\sqrt{3}}{2} - T = 4a \quad \dots (1)$$

$$T - \frac{g}{2} = 1a \quad \dots (2)$$

$$2\sqrt{3}g - T = 4\left(T - \frac{g}{2}\right) \Rightarrow 5T = (2\sqrt{3} + 2)g$$

$$T = \frac{10}{5}(2\sqrt{3} + 2) \Rightarrow T = 4(\sqrt{3} + 1)N$$

20. Given below are two statements: one is labelled as Assertion **A** and the other is labelled as Reason **R**
 Assertion **A**: Photodiodes are preferably operated in reverse bias condition for light intensity measurement.

Reason **R**: The current in the forward bias is more than the current in the reverse bias for a $p - n$ junction diode.

In the light of the above statements, choose the correct answer from the options given below:

- (1) **A** is true but **R** is false
- (2) **A** is false but **R** is true
- (3) Both **A** and **R** are true and **R** is the correct explanation of **A**
- (4) Both **A** and **R** are true but **R** is NOT the correct explanation of **A**

Sol. 4

Photodiode works in reverse bias and its is used as a intensity detector . (True)

Forward bias current is more as compaired to reverse bias current (True)

SECTION - B

- 21.** Vectors $a\hat{i} + b\hat{j} + \hat{k}$ and $2\hat{i} - 3\hat{j} + 4\hat{k}$ are perpendicular to each other when $3a + 2b = 7$, the ratio of a to b is $\frac{x}{2}$. The value of x is

Sol. 1

$a\hat{i} + b\hat{j} + \hat{k}$ is \perp to $(2\hat{i} - 3\hat{j} + 4\hat{k})$

$$\vec{A} \cdot \vec{B} = 0 \Rightarrow 2a - 3b - 4 = 0$$

$$2a - 3b = -4$$

Given $3a + 2b = 7$

$$\frac{2\left(\frac{a}{b}\right) - 3}{3\left(\frac{a}{b}\right) + 2} = \frac{-4}{7} \Rightarrow 14\frac{a}{b} - 21 = -12\frac{a}{b} - 8$$

$$26\frac{a}{b} = 13 \Rightarrow \frac{a}{b} = \frac{1}{2} = \frac{x}{2}$$

$$x = 1$$

- 22.** Assume that protons and neutrons have equal masses. Mass of a nucleon is 1.6×10^{-27} kg and radius of nucleus is $1.5 \times 10^{-15} A^{1/3}$ m. The approximate ratio of the nuclear density and water density is $n \times 10^{13}$. The value of n is

Sol. 11

$$\rho_{\text{Nucleus}} = \frac{A(m)}{\frac{4}{3}\pi R^3} \Rightarrow$$

$$\rho_N = \frac{3}{4\pi} \frac{Am}{\left(1.5 \times 10^{-15} A^{1/3}\right)^3}$$

$$\frac{\rho_N}{\rho_w} = \frac{3}{4\pi} \frac{(1.6) \times 10^{-27}}{(1.5)^3 \times 10^{-45} \times 10^3}$$

$$\frac{\rho_N}{\rho_w} = 11 \times 10^{13}$$

- 23.** A hollow cylindrical conductor has length of 3.14 m, while its inner and outer diameters are 4 mm and 8 mm respectively. The resistance of the conductor is $n \times 10^{-3} \Omega$. If the resistivity of the material is $2.4 \times 10^{-8} \Omega\text{m}$. The value of n is

Sol. 2

$$R = \frac{\rho \ell}{A} \Rightarrow R = \frac{\rho \ell}{\pi(r_2^2 - r_1^2)}$$

$$R = \frac{2.4 \times 10^{-8} \times 3.14}{\pi(4^2 - 2^2) \times 10^{-6}}$$

$$R = 2 \times 10^{-3} \Omega$$

24. A stream of a positively charged particles having $\frac{q}{m} = 2 \times 10^{11} \frac{C}{kg}$ and velocity $\vec{v}_0 = 3 \times 10^7 \hat{i} m/s$ is deflected by an electric field $1.8 \hat{j} kV/m$. The electric field exists in a region of 10 cm along x direction. Due to the electric field, the deflection of the charge particles in the y direction is _____ mm

Sol. 2

$$y = \frac{1}{2} a t^2$$

$$y = \frac{1}{2} \frac{qE}{m} t^2$$

$$\ell = v_0 t$$

$$y = \frac{1}{2} \frac{qE}{m} \left(\frac{\ell}{v_0} \right)^2$$

$$y = \frac{1}{2} (2 \times 10^{11}) (1.8 \times 10^3) \left(\frac{0.1}{3 \times 10^7} \right)^2$$

$$y = 2 \text{ mm}$$

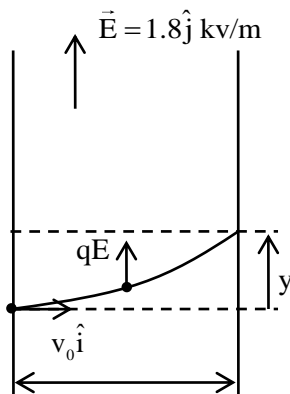

25. As shown in the figure, a combination of a thin plano concave lens and a thin plano convex lens is used to image an object placed at infinity. The radius of curvature of both the lenses is 30 cm and refraction index of the material for both the lenses is 1.75. Both the lenses are placed at distance of 40 cm from each other. Due to the combination, the image of the object is formed at distance = ___ cm, from concave lens.

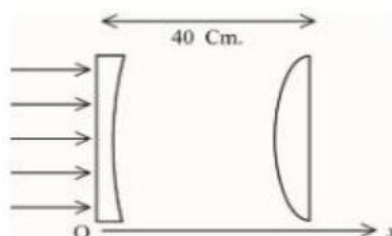

Sol. 120

Magnitude of focal length of both lens

$$f = \frac{R}{\mu - 1} \Rightarrow f = \frac{30}{1.75 - 1} \Rightarrow f = 40 \text{ cm}$$

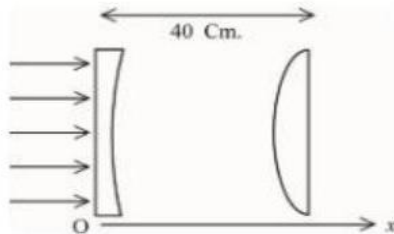

$$f = -40 \text{ cm} \qquad f = +40 \text{ cm}$$

Concave lens will form image at its focus for convex lens $\frac{1}{v} - \frac{1}{u} = \frac{1}{f} \Rightarrow \frac{1}{v} - \frac{1}{-80} = \frac{1}{+40}$

$$v = +80 \text{ cm}$$

From concave lens distance of image of $d = 80 + 40$

$$d = 120 \text{ cm}$$

- 26.** Solid sphere A is rotating about an axis PQ. If the radius of the sphere is 5 cm then its radius of gyration about PQ will be \sqrt{x} cm. The value of x is _____

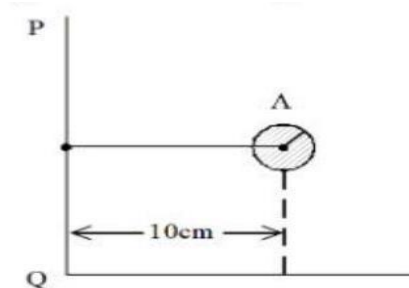

Sol. 110

$$I_{PQ} = I_{cm} + md^2$$

$$mk^2 = \frac{2}{5} mR^2 + md^2 \Rightarrow k = \sqrt{\frac{2}{5}(5)^2 + (10)^2}$$

$$k = \sqrt{110} \text{ cm}$$

- 27.** A block of a mass 2 kg is attached with two identical springs of spring constant 20 N/m each. The block is placed on a frictionless surface and the ends of the springs are attached to rigid supports (see figure). When the mass is displaced from its equilibrium position, it executes a simple harmonic motion. The time period of oscillation is $\frac{\pi}{\sqrt{x}}$ in SI unit. The value of x is _____

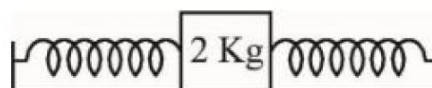

Sol. 5

$$T = 2\pi \sqrt{\frac{m}{k_{eq}}}$$

$$T = 2\pi \sqrt{\frac{2}{2k}} \Rightarrow T = 2\pi \sqrt{\frac{1}{20}}$$

$$T = \frac{\pi}{\sqrt{5}}$$

28. A hole is drilled in a metal sheet. At 27°C , the diameter of hole is 5 cm. When the sheet is heated to 177°C , the change in the diameter of hole is $d \times 10^{-3}$ cm. The value of d will be _____ if coefficient of linear expansion of the metal is $1.6 \times 10^{-5}/^\circ\text{C}$.

Sol. 12

$$\Delta D = D \propto \Delta T$$

$$\Delta D = 5 \times 1.6 \times 10^{-5} \times (177 - 27)$$

$$\Delta D = 12 \times 10^{-3} \text{ cm}$$

29. In the circuit shown in the figure, the ratio of the quality factor and the band width is _____ S.

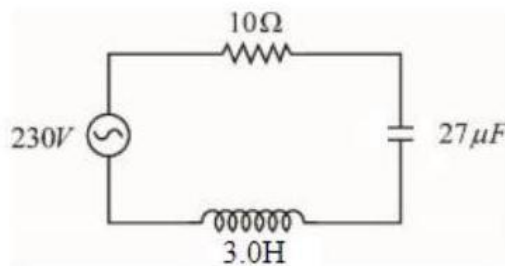

Sol. 10

$$Q = \frac{1}{R} \sqrt{\frac{L}{C}} \text{ \& bandwidth} = \frac{R}{L}$$

$$\frac{Q}{\text{Bandwidth}} = \frac{L}{R^2} \sqrt{\frac{L}{C}}$$

$$= \frac{3}{100} \times \sqrt{\frac{3}{27 \times 10^{-6}}}$$

$$= 10$$

30. A spherical body of mass 2 kg starting from rest acquires a kinetic energy of 10000 J at the end of 5th second. The force acted on the body is _____ N.

Sol. 40

$$\text{Impulse} = \Delta P$$

$$F\Delta T = P - 0 \Rightarrow F\Delta T = \sqrt{2mk}$$

$$F(5) = \sqrt{2 \times 2 \times 10000}$$

$$F = 40 \text{ N}$$

Chemistry

SECTION - A

31. 'A' and 'B' formed in the following set of reactions are:

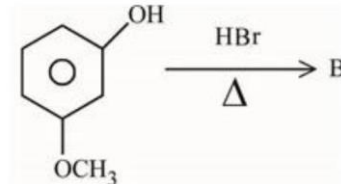
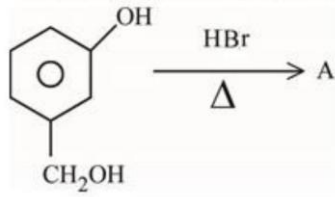

- (1) A = Oc1cccc(CBr)c1, B = Oc1cccc(OC)c1 (2) A = Oc1cccc(CO)c1, B = Oc1ccc(O)cc1
- (3) A = Oc1ccc(Br)cc1, B = Oc1ccc(Br)cc1 (4) A = Oc1cccc(CO)c1, B = Oc1ccc(Br)cc1

Sol. 2

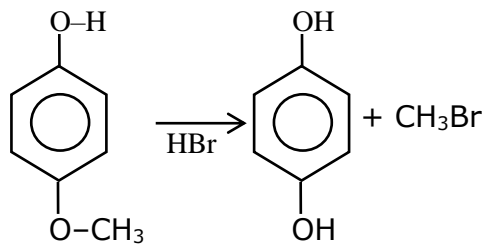
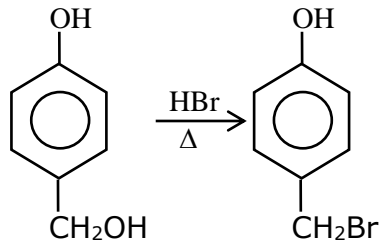

32. Decreasing order of the hydrogen bonding in following forms of water is correctly represented by

- A. Liquid water
B. Ice
C. Impure water

Choose the correct answer from the options given below:

- (1) $B > A > C$ (2) $A > B > C$ (3) $A = B > C$ (4) $C > B > A$

Sol. 1
 ice > liquid water > impure water
 OR
 ice > H₂O liq. > impure H₂O
 Hydrogen bond $\propto \frac{1}{\text{Temp}}$

33. Increasing order of stability of the resonance structures is:

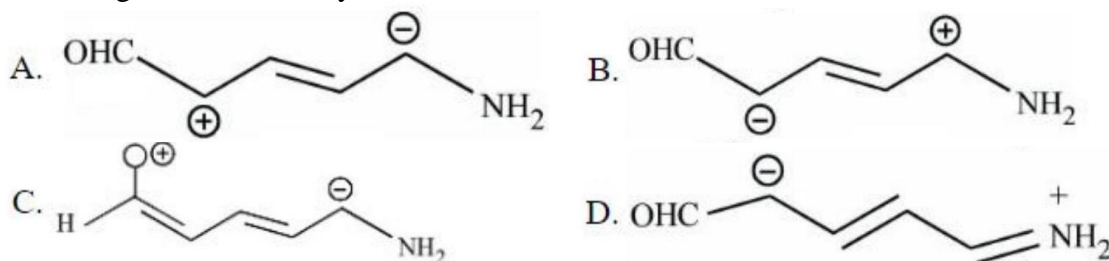

Choose the correct answer from the options given below:

- (1) D, C, A, B (2) D, C, B, A (3) C, D, A, B (4) 4. C, D, B, A

Sol. Bonus

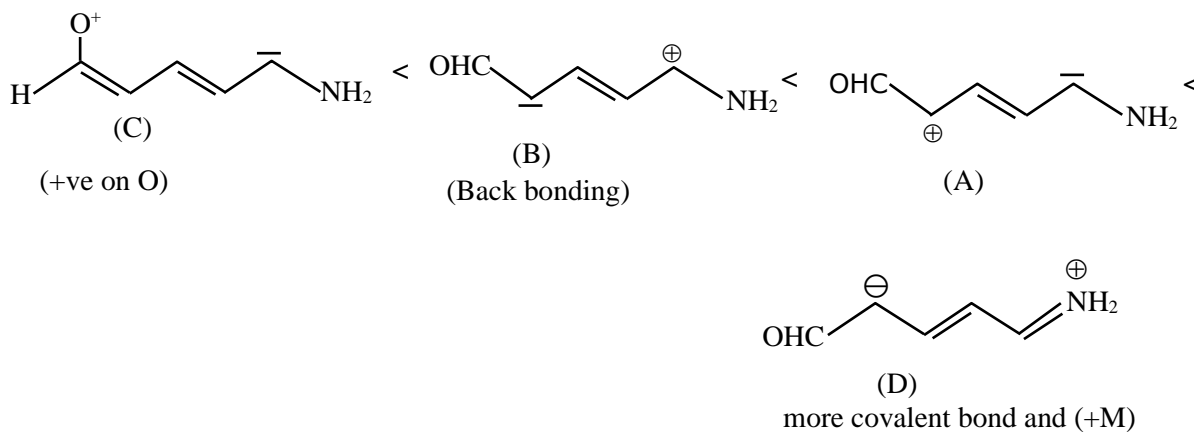

Final correct order C<B<A<D

34. 'R' formed in the following sequence of reactions is:

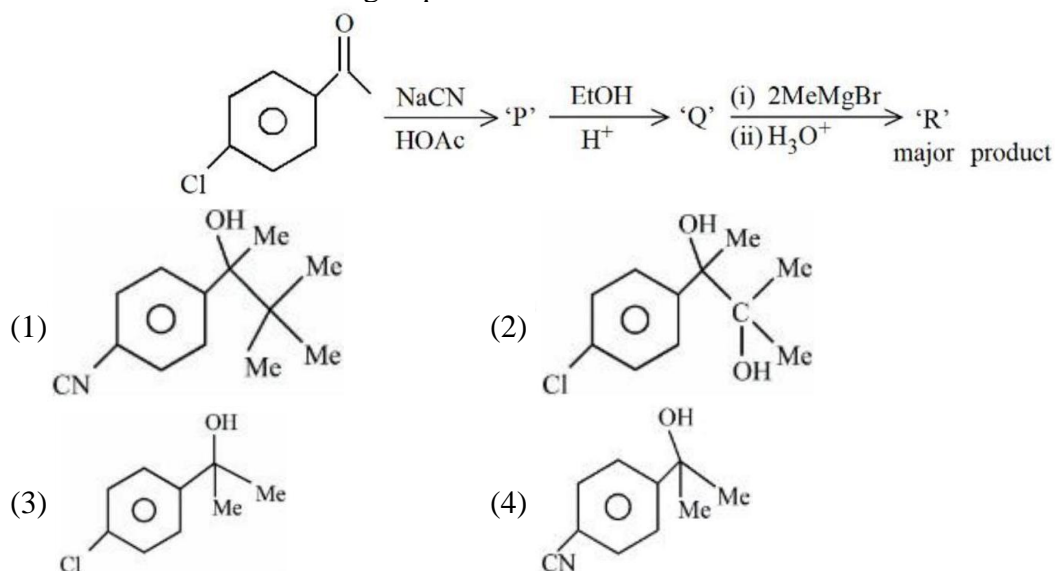

Sol. 2

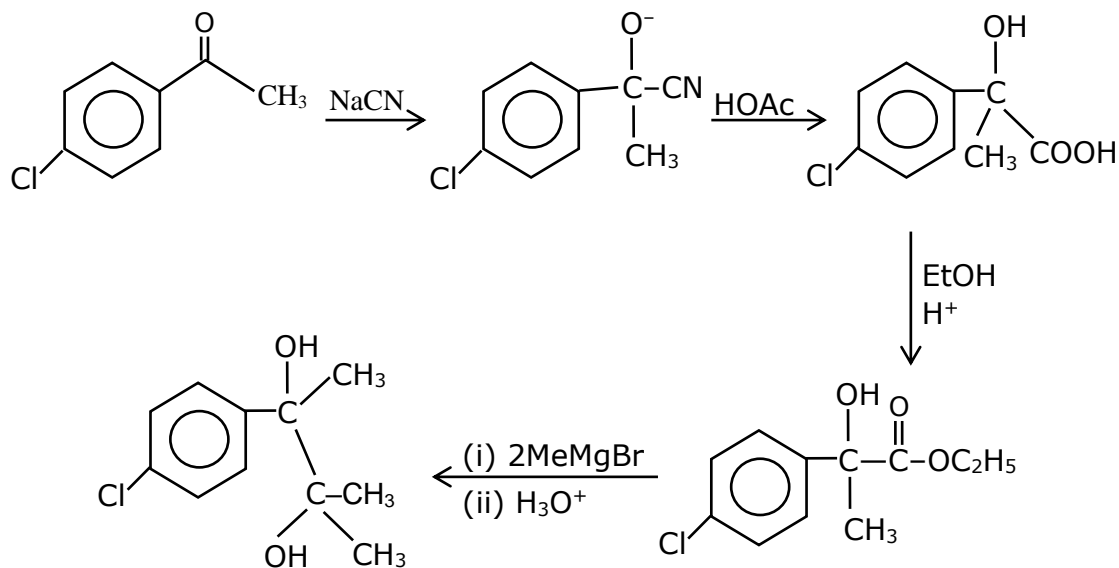

35. The primary and secondary valencies of cobalt respectively in $[\text{Co}(\text{NH}_3)_5\text{Cl}]\text{Cl}_2$ are:
 (1) 3 and 6 (2) 2 and 6 (3) 3 and 5 (4) 2 and 8

Sol. 1

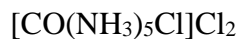

36. An ammoniacal metal salt solution gives a brilliant red precipitate on addition of dimethylglyoxime. The metal ion is:

- (1) Co^{2+} (2) Ni^{2+} (3) Fe^{2+} (4) Cu^{2+}

Sol. 2

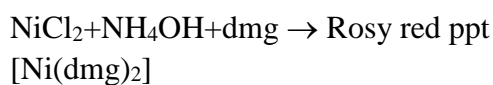

37. Reaction of BeO with ammonia and hydrogen fluoride gives A which on thermal decomposition gives BeF_2 and NH_4F . What is 'A' ?

- (1) $(\text{NH}_4)_2\text{BeF}_4$ (2) H_3NBeF_3 (3) $(\text{NH}_4)\text{Be}_2\text{F}_5$ (4) $(\text{NH}_4)\text{BeF}_3$

Sol. 1

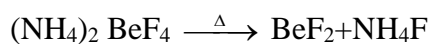

38. Match List I with List II

LIST I		LIST II	
A.	Reverberatory furnace	I.	Pig Iron
B.	Electrolytic cell	II.	Aluminum
C.	Blast furnace	III.	Silicon
D.	Zone Refining furnace	IV.	Copper

Choose the correct answer from the options given below:

- (1) A-IV, B-II, C-I, D-III (2) A-I, B-III, C-II, D-IV
 (3) A-III, B-IV, C-I, D-II (4) A-I, B-IV, C-II, D-III

Sol. 1

Reverberatory furnace \rightarrow Cr

Electrolysis cell \rightarrow Ar

Blast furnace \rightarrow Pig iron

Zone refining furnace \rightarrow silicon

39. Match List I with List II

LIST I		LIST II	
A.	Chlorophyll	I.	Na_2CO_3
B.	Soda ash	II.	CaSO_4
C.	Dentistry, Ornamental work	III.	Mg^{2+}
D.	Used in white washing	IV.	$\text{Ca}(\text{OH})_2$

Choose the correct answer from the options given below:

(1) A-II, B-I, C-III, D-IV (2) A-III, B-I, C-II, D-IV

(3) A-II, B-III, C-IV, D-I (4) A-III, B-IV, C-I, D-II

Sol. 2

Chlorophyll $\rightarrow \text{Mg}^{2+}$

Soda ash $\rightarrow \text{Na}_2\text{CO}_3$

Dentistry &

ornamental work $\rightarrow \text{CaSO}_4$

White washing $\rightarrow \text{Ca}(\text{OH})_2$

40. In the following given reaction, 'A' is

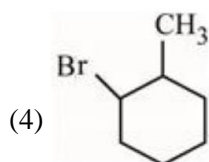
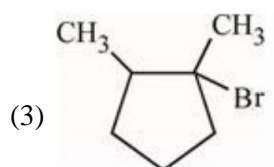
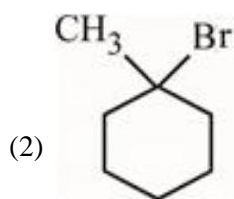
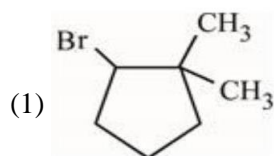
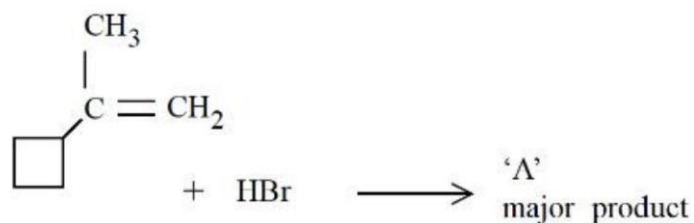

Sol. 3

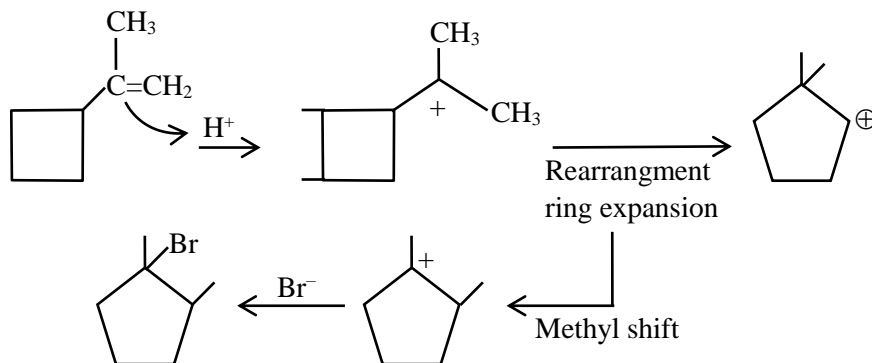

41. It is observed that characteristic X-ray spectra of elements show regularity. When frequency to the power " n " i.e. ν^n of X-rays emitted is plotted against atomic number " Z ", following graph is obtained.

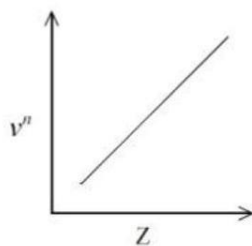

The value of " n " is

(1) 3

(2) 2

(3) 1

(4) $\frac{1}{2}$

Sol. 4

$$\sqrt{\nu} \propto Z$$

$$\nu^n \propto Z$$

$$n = 1/2$$

42. Given below are two statements:

Statement I : Noradrenaline is a neurotransmitter.

Statement II : Low level of noradrenaline is not the cause of depression in human.

In the light of the above statements, choose the correct answer from the options given below

(1) Statement I is correct but Statement II is incorrect

(2) Both Statement I and Statement II are correct

(3) Both Statement I and Statement II are incorrect

(4) Statement I is incorrect but Statement II is correct

Sol. 1

Fact

43. Which of the Phosphorus oxoacid can create silver mirror from $AgNO_3$ solution?

(1) $(HPO_3)_n$

(2) $H_4P_2O_6$

(3) $H_4P_2O_5$

(4) $H_4P_2O_7$

Sol. 3

Silver mirror test can give by p^{+3} , p^{+1} ox acid

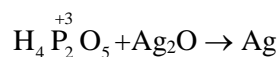

Silver mirror

44. Compound (X) undergoes following sequence of reactions to give the Lactone (Y).

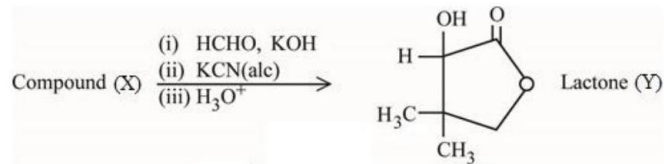

Compound (X) is

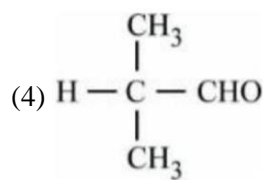
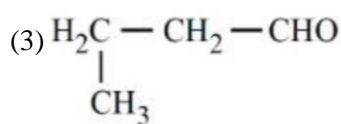
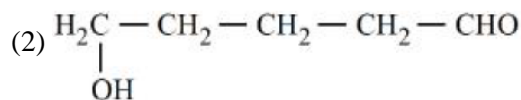
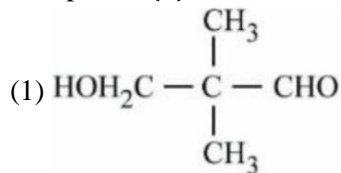

Sol. 4

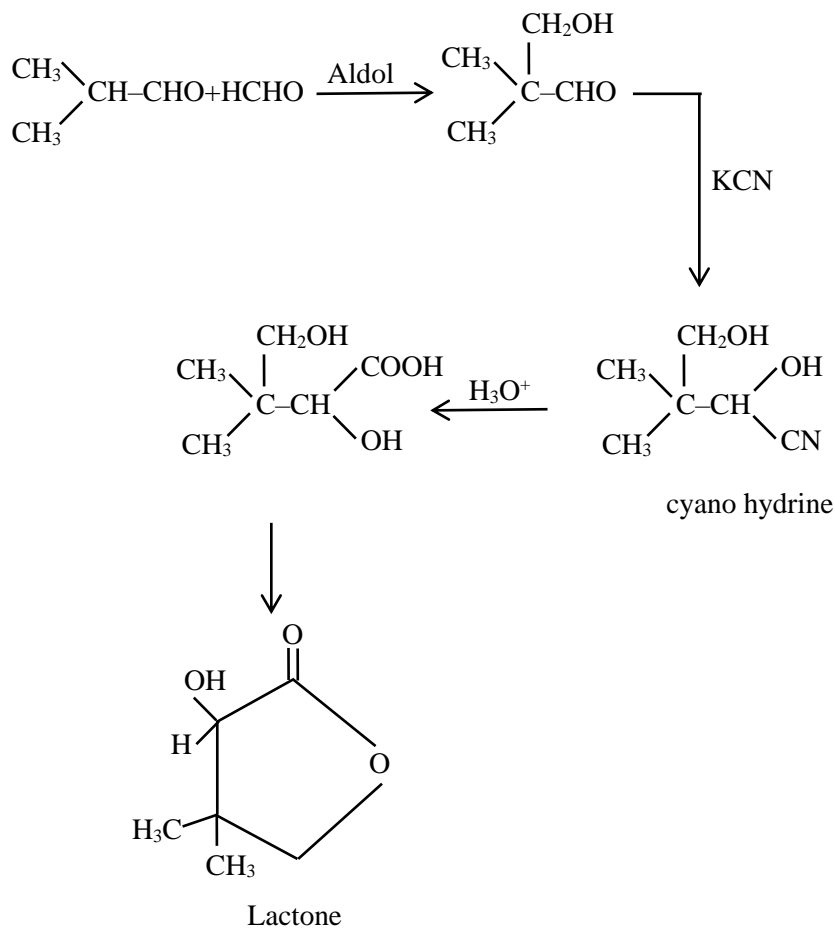

45. Order of Covalent bond;

A. $\text{KF} > \text{KI}; \text{LiF} > \text{KF}$

B. $\text{KF} < \text{KI}; \text{LiF} > \text{KF}$

C. $\text{SnCl}_4 > \text{SnCl}_2; \text{CuCl} > \text{NaCl}$

D. $\text{LiF} > \text{KF}; \text{CuCl} < \text{NaCl}$

E. $\text{KF} < \text{KI}; \text{CuCl} > \text{NaCl}$

Choose the correct answer from the options given below:

(1) C, E only

(2) B, C, E only

(3) A, B only

(4) B, C only

Sol. 2

Small size of +ve ion }
 longer size of -ve ion } move covalent according to Fajan's rule

46. Which of the following is true about freons?
 (1) These are radicals of chlorine and chlorine monoxide
 (2) These are chemicals causing skin cancer
 (3) These are chlorofluorocarbon compounds
 (4) All radicals are called freons

Sol. **3**
 Freons → chlorofluorocarbon compounds

47. In the depression of freezing point experiment
 A. Vapour pressure of the solution is less than that of pure solvent
 B. Vapour pressure of the solution is more than that of pure solvent
 C. Only solute molecules solidify at the freezing point
 D. Only solvent molecules solidify at the freezing point
 Choose the most appropriate answer from the options given below:

(1) A and C only (2) A only (3) A and D only (4) B and C only
 Sol. **3**
 On adding non-volatile solute to pure solvent, depression in freezing point and lowering in vapour pressure occurs.

48. **Statement I :** For colloidal particles, the values of colligative properties are of small order as compared to values shown by true solutions at same concentration.

Statement II : For colloidal particles, the potential difference between the fixed layer and the diffused layer of same charges is called the electrokinetic potential or zeta potential.

In the light of the above statements, choose the correct answer from the options given below

- (1) Options 1. Statement I is false but Statement II is true
 (2) Statement I is true but Statement II is false
 (3) Both Statement I and Statement II are true
 (4) Both Statement I and Statement II are false

Sol. **2**
 These layers should be of opposite charges

49. **Assertion A :** Hydrolysis of an alkyl chloride is a slow reaction but in the presence of NaI, the rate of the hydrolysis increases.

Reason R : I⁻ is a good nucleophile as well as a good leaving group.

In the light of the above statements, choose the correct answer from the options given below

- (1) **A** is false but **R** is true
 (2) **A** is true but **R** is false
 (3) Both **A** and **R** are true but **R** is NOT the correct explanation of **A**
 (4) Both **A** and **R** are true and **R** is the correct explanation of **A**

Sol. **3**
 The rate of hydrolysis of alkyl chloride improves because of better Nucleophilicity of I⁻.

50. The magnetic moment of a transition metal compound has been calculated to be 3.87 B.M. The metal ion is
 (1) Cr²⁺ (2) Ti²⁺ (3) V²⁺ (4) Mn²⁺

Sol. **3**
 $\sqrt{n(n+2)} = 3.87$
 $n = 3 = \text{no. of unpaired } e^-$
 Cr²⁺ = [Ar] 3d⁴
 Ti²⁺ = [Ar] 3d²
 V²⁺ = [Ar] 3d³

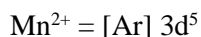

SECTION - B

51. When $\text{Fe}_{0.93}\text{O}$ is heated in presence of oxygen, it converts to Fe_2O_3 . The number of correct statement/s from the following is

- A. The equivalent weight of $\text{Fe}_{0.93}\text{O}$ is $\frac{\text{Molecular weight}}{0.79}$
- B. The number of moles of Fe^{2+} and Fe^{3+} in 1 mole of $\text{Fe}_{0.93}\text{O}$ is 0.79 and 0.14 respectively
- C. $\text{Fe}_{0.93}\text{O}$ is metal deficient with lattice comprising of cubic closed packed arrangement of O^{2-} ions
- D. The % composition of Fe^{2+} and Fe^{3+} in $\text{Fe}_{0.93}\text{O}$ is 85% and 15% respectively

Sol. **4**



$$2x + (0.93 - x)3 = 2$$

$$-x + 3 \times 0.93 = 2$$

$$x = 0.79$$

$$0.79 = \text{no. of } \text{Fe}^{2+} \text{ ion}$$

$$0.14 = \text{no. of } \text{Fe}^{3+} \text{ ion}$$

$$nf = 0.79$$

$$\text{Equivalent wt} = \frac{\text{Molecular weight}}{0.79}$$

Due to presence of Fe^{3+} in FeO lattice, Metal deficiency occurs.

$$\% \text{ Composition :- } \text{Fe}^{2+} \text{ ions} = \frac{0.79}{0.93} \times 100$$

85%

$$\text{Fe}^{3+} \text{ ion} = \frac{0.14}{0.93} \times 100$$

15%

52. The number of correct statement/s from the following is

- A. Larger the activation energy, smaller is the value of the rate constant.
- B. The higher is the activation energy, higher is the value of the temperature coefficient.
- C. At lower temperatures, increase in temperature causes more change in the value of k than at higher temperature
- D. A plot of $\ln k \nu \frac{1}{T}$ is a straight line with slope equal to $-\frac{E_a}{R}$

Sol. **4**

$$K = A e^{-E_a/RT}$$

Here, $E_a \uparrow K \downarrow$

$$\ln K = \ln A - E_a/RT$$

$$\text{slope of } \ln K \text{ vs } 1/T = -E_a/R$$

The higher is the activation energy, higher is the value of the temperature coefficient.

53. For independent processes at 300 K

Process	$\Delta H/\text{kJ mol}^{-1}$	$\Delta S/\text{J K}^{-1}$
A	-25	-80
B	-22	40
C	25	-50
D	22	20

The number of non-spontaneous processes from the following is

Sol.

2

For process A

$$\Delta G = -25 \times 10^3 - 300(-80)$$

$$= -25000 + 24000$$

$$= -1000 \Rightarrow \Delta G < 0 \text{ spontaneous}$$

For process B

$$\Delta G = -22 \times 10^3 - 300(40)$$

$$= -22000 - 12000 \Rightarrow \Delta G < 0 \text{ spontaneous}$$

For process C

$$\Delta G = 25 \times 10^3 - 300(-50)$$

$$= 25000 + 15000 = 40000 \text{ J}$$

$$\Delta G > 0 \Rightarrow \text{Non-spontaneous}$$

For process D

$$\Delta G = 22 \times 10^3 - 300(20)$$

$$\Delta G > 0 \Rightarrow \text{Non-spontaneous.}$$

54. 5 g of NaOH was dissolved in deionized water to prepare a 450 mL stock solution. What volume (in mL) of this solution would be required to prepare 500 mL of 0.1M solution?

Given: Molar Mass of Na, O and H is 23,16 and 1 g mol⁻¹ respectively

Sol.

180

Molarity of stock solution

$$= \frac{5/40}{450} \times 1000$$

$$= \frac{50}{4 \times 45} = \frac{10}{36} \text{ M}$$

$$M_1 V_1 = M_2 V_2$$

$$\frac{10}{36} \times V = 0.1 \times 500$$

$$V = \frac{50 \times 36}{10} = 180 \text{ ml}$$

55. If wavelength of the first line of the Paschen series of hydrogen atom is 720 nm, then the wavelength of the second line of this series is nm. (Nearest integer)

Sol.

492

Paschen series :-

$$z = 1$$

Ist line :- 4 → 3

$$\frac{1}{\lambda} = R \times (1)^2 \left(\frac{1}{3^2} - \frac{1}{4^2} \right)$$

$$\frac{1}{720} = R \left(\frac{7}{144} \right) \quad (1)$$

IInd line → 5 → 3

$$\frac{1}{\lambda} = R \times (1)^2 \left(\frac{1}{3^2} - \frac{1}{5^2} \right)$$

$$\frac{1}{\lambda} = R \left(\frac{16}{225} \right) \quad (2)$$

Equation (2) ÷ equation (1)

$$\frac{\lambda}{720} = \frac{7}{144} \times \frac{225}{16}$$

$$\lambda = 492.18$$

56. Uracil is a base present in RNA with the following structure. % of N in uracil is

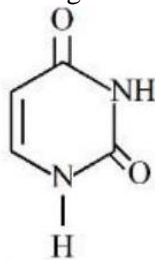

Sol. **25**

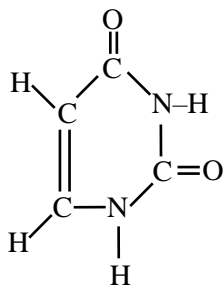

Molecular formula of uracil



$$\% \text{ of N} = \frac{28}{112} \times 100 = 25\%$$

57. The dissociation constant of acetic acid is $x \times 10^{-5}$. When 25 mL of 0.2M CH_3COONa solution is mixed with 25 mL of 0.02M CH_3COOH solution, the pH of the resultant solution is found to be equal to 5. The value of x is

Sol. **10**

$$K_a = x \times 10^{-5}$$

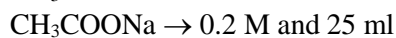
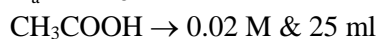

$$pH = p^{K_a} + \log \frac{[\text{salt}]}{[\text{acid}]}$$

$$5 = p^{K_a} + \log \frac{0.2 \times 25}{0.02 \times 25} = p^{K_a} + \log 10$$

$$p^{K_a} = 4$$

$$K_a = 10^{-4} = 10 \times 10^{-5}$$

Hence $x = 10$

58. Number of moles of $AgCl$ formed in the following reaction is _____

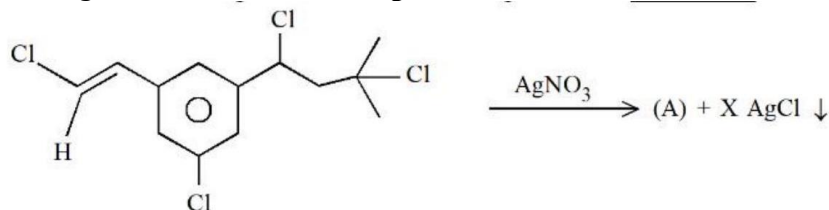

Sol. **2**

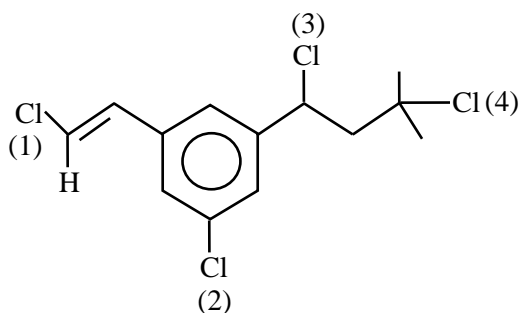

After treat with AgNO_3 , Cl^- remove and possible carbocation will form
 Position 1 : Vinylic carbocation forms, unstable, So not possible
 Position 2 : sp^2 hybridised carbocation is unstable, so not possible
 Position 3 : Forms 2° carbocation which will be in conjugation with ring
 Position 4 : 3° stable carbocation will form.

59. The d-electronic configuration of $[\text{CoCl}_4]^{2-}$ in tetrahedral crystal field is $e^m t_2^n$. Sum of "m" and "number of unpaired electrons" is

Sol.

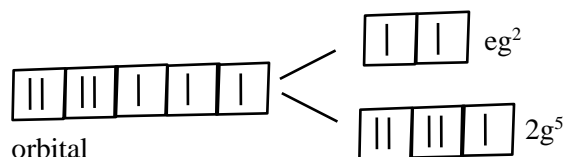
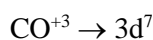

60. At 298 K, a 1 litre solution containing 10mmol of $\text{Cr}_2\text{O}_7^{2-}$ and 100mmol of Cr^{3+} shows a pH of 3.0.

Given: $\text{Cr}_2\text{O}_7^{2-} \rightarrow \text{Cr}^{3+}$; $E^\circ = 1.330 \text{ V}$ and $\frac{2.303RT}{F} = 0.059 \text{ V}$

The potential for the half cell reaction is $x \times 10^{-3} \text{ V}$. The value of x is

Sol.

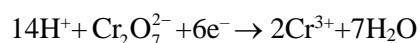

$$E = E^\circ - \frac{2.303RT}{6F} \log \frac{[\text{Cr}^{3+}]^2}{[\text{Cr}_2\text{O}_7^{2-}][\text{H}^+]^{14}}$$

$$\text{pH} = 3$$

$$[\text{H}^+] = 10^{-3}$$

$$E = 1.330 - \frac{0.059}{6} \log \frac{10^{-2}}{10^{-2}(10^{-42})}$$

$$E = 0.917$$

$$= 917 \times 10^{-3}$$

$$x = 917$$

Mathematics

SECTION - A

- 61.** Let $\vec{u} = \hat{i} - \hat{j} - 2\hat{k}$, $\vec{v} = 2\hat{i} + \hat{j} - \hat{k}$, $\vec{v} \cdot \vec{w} = 2$ and $\vec{v} \times \vec{w} = \vec{u} + \lambda\vec{v}$. Then $\vec{u} \cdot \vec{w}$ is equal to
 (1) 2 (2) $\frac{3}{2}$ (3) 1 (4) $-\frac{2}{3}$

Sol. (3)

$$\vec{v} \cdot \vec{w} = \vec{u} + \lambda\vec{v}$$

$$\vec{v} \cdot \vec{w} \cdot \vec{v} = \vec{u} \cdot \vec{v} + \lambda\vec{v} \cdot \vec{v}$$

$$0 = 2 - 1 + 2 + \lambda(4 + 1 + 1)$$

$$\lambda = \frac{-3}{6} \Rightarrow \lambda = -\frac{1}{2}$$

Now

$$\vec{v} \times \vec{w} = \vec{u} + \lambda\vec{v}$$

$$\vec{v} \times \vec{w} \cdot \vec{w} = \vec{u} \cdot \vec{w} + \lambda\vec{v} \cdot \vec{w}$$

$$0 = \vec{u} \cdot \vec{w} + \lambda \cdot 2$$

$$\vec{u} \cdot \vec{w} = -2\lambda = 1$$

- 62.** $\lim_{t \rightarrow 0} \left(1^{\frac{1}{\sin^2 t}} + 2^{\frac{1}{\sin^2 t}} + \dots + n^{\frac{1}{\sin^2 t}} \right)^{\sin^2 t}$ is equal to
 (1) n^2 (2) $\frac{n(n+1)}{2}$ (3) n (4) $n^2 + n$

Sol. (3)

$$\lim_{t \rightarrow 0} \left(1^{\frac{1}{\sin^2 t}} + 2^{\frac{1}{\sin^2 t}} + \dots + n^{\frac{1}{\sin^2 t}} \right)^{\sin^2 t}$$

$$= \lim_{t \rightarrow 0} n \left(\left(\frac{1}{n} \right)^{\frac{1}{\sin^2 t}} + \left(\frac{2}{n} \right)^{\frac{1}{\sin^2 t}} + \dots + \left(\frac{n-1}{n} \right)^{\frac{1}{\sin^2 t}} + 1 \right)^{\sin^2 t}$$

$$= n \cdot [0 + 0 + \dots + 1]^0$$

$$= \boxed{n}$$

- 63.** Let α be a root of the equation $(a - c)x^2 + (b - a)x + (c - b) = 0$

where a, b, c are distinct real numbers such that the matrix $\begin{bmatrix} \alpha^2 & \alpha & 1 \\ 1 & 1 & 1 \\ a & b & c \end{bmatrix}$

is singular. Then, the value of $\frac{(a-c)^2}{(b-a)(c-b)} + \frac{(b-a)^2}{(a-c)(c-b)} + \frac{(c-b)^2}{(a-c)(b-a)}$ is

- (1) 12 (2) 9 (3) 3 (4) 6

Sol. (3)

$$(a - c)x^2 + (b - a)x + (c - b) = 0 \quad (a \neq c)$$

$$\boxed{x=1} \text{ is one root \& other root is } \boxed{\frac{c-b}{a-c}} \quad \dots(1)$$

$$\text{now } \begin{vmatrix} \alpha^2 & \alpha & 1 \\ 1 & 1 & 1 \\ a & b & c \end{vmatrix} \text{ is singular}$$

$$\Rightarrow \begin{vmatrix} \alpha^2 & \alpha & 1 \\ 1 & 1 & 1 \\ a & b & c \end{vmatrix} = 0 \Rightarrow \alpha^2(c-b) - \alpha(c-a) + (b-a) = 0$$

$$\Rightarrow \alpha^2(c-b) + \alpha(a-c) + (b-a) = 0$$

$$\text{satisfied by } \boxed{\alpha=1} \text{ or } \boxed{\alpha = \frac{b-a}{c-b}} \quad \dots(2)$$

Now, if $\alpha = 1$ then $\forall a \neq b \neq c$

$$\sum \frac{(a-c)^2}{(b-a)(c-b)} = \frac{\sum (a-c)^3}{(a-b)(b-c)(c-a)}$$

$$= \frac{3(a-b)(b-c)(c-a)}{(a-b)(b-c)(c-a)}$$

$$= 3$$

$$[\text{if } A+B+C=0 \Rightarrow A^3+B^3+C^3 = 3ABC]$$

64. The area enclosed by the curves $y^2 + 4x = 4$ and $y - 2x = 2$ is :

$$(1) 9 \quad (2) \frac{22}{3} \quad (3) \frac{23}{3} \quad (4) \frac{25}{3}$$

Sol. (1)

$$y^2 + 4x = 4$$

&

$$y = 2 + 2x$$

$$P: y^2 = 4(1-x)$$

$$L: y = 2(1+x)$$

Now

$$y^2 + 4\left(\frac{y}{2} - 1\right) = 4$$

$$y^2 + 2y - 8 = 0$$

$$(y+4)(y-2) = 0$$

required Area

$$A = \int_{-4}^2 \left[\left(\frac{4-y^2}{4} \right) - \left(\frac{y-2}{2} \right) \right] dy$$

$$A = \int_{-4}^2 \left(2 - \frac{y^2}{4} - \frac{y}{2} \right) dy$$

$$= \left[2y - \frac{y^3}{12} - \frac{y^2}{4} \right]_{-4}^2$$

$$= \left(4 - \frac{8}{12} - 1 \right) - \left(-8 + \frac{64}{12} - 4 \right)$$

$$A = \boxed{9}$$

65. Let $p, q \in \mathbb{R}$ and $(1 - \sqrt{3}i)^{200} = 2^{199}(p + iq)$, $i = \sqrt{-1}$ Then $p + q + q^2$ and $p - q + q^2$ are roots of the equation

(1) $x^2 - 4x - 1 = 0$ (2) $x^2 - 4x + 1 = 0$ (3) $x^2 + 4x - 1 = 0$ (4) $x^2 + 4x + 1 = 0$

Sol. (2)

$$(1 - \sqrt{3}i)^{200} = 2^{199}(p + iq)$$

$$\Rightarrow 2^{200} \operatorname{cis}\left(\frac{-\pi}{3}\right)^{200} = 2^{199}(p + iq)$$

$$\Rightarrow 2^{200} \left(\operatorname{cis}\left(-\frac{200\pi}{3}\right) \right) = 2^{199}(p + iq)$$

$$\Rightarrow 2 \left(\operatorname{cis}\left(-66\pi - \frac{2\pi}{3}\right) \right) = (p + iq)$$

$$\Rightarrow 2 \left[\operatorname{cis}\left(\frac{-2\pi}{3}\right) \right] = (p + iq)$$

$$\Rightarrow 2 \left[\frac{-1}{2} - \frac{\sqrt{3}i}{2} \right] = (p + iq)$$

$$\Rightarrow p = -1, q = -\sqrt{3}$$

Now

$$\alpha = p + q + q^2 = 2 - \sqrt{3}$$

$$\beta = p - q + q^2 = 2 + \sqrt{3}$$

$$\text{req. quad is } x^2 - 4x + 1 = 0$$

66. Let N denote the number that turns up when a fair die is rolled. If the probability that the system of equations

$$x + y + z = 1$$

$$2x + Ny + 2z = 2$$

$$3x + 3y + Nz = 3$$

has unique solution is $\frac{k}{6}$, then the sum of value of k and all possible values of N is

(1) 21

(2) 18

(3) 20

(4) 19

Sol. (3)

for unique solu.

$$\Delta \neq 0$$

$$\begin{vmatrix} 1 & 1 & 1 \\ 2 & N & 2 \\ 3 & 3 & N \end{vmatrix} \neq 0$$

$$\Rightarrow (N^2 - 6) - (2N - 6) + (6 - 3N) \neq 0$$

$$\Rightarrow N^2 - 5N + 6 \neq 0$$

$$\Rightarrow N \neq 3$$

&

$$N \neq 2$$

Hence N can be $\{1, 4, 5, 6\}$ Fav case : $\frac{4}{6} = \frac{k}{6} \Rightarrow \boxed{k = 4}$

Sum = $\boxed{20}$

67. For three positive integers p, q, r , $x^{pq^2} = y^{qr} = z^{p^2r}$ and $r = pq + 1$ such that $3, 3\log_y x, 3\log_z y, 7\log_x z$ are in A.P. with common difference $\frac{1}{2}$. Then $r - p - q$ is equal to
- (1) -6 (2) 12 (3) 6 (4) 2

Sol. (4)

$$x^{pq^2} = y^{qr} = z^{p^2r} \quad \& \quad r = pq + 1$$

$3, 3\log_y x, 3\log_z y, 7\log_x z$ are in A.P.

Now

$$3\log_y x = 3 + \frac{1}{2} = \frac{7}{2} \Rightarrow \log_y x = \frac{7}{6}$$

$$x^6 = y^7 \quad \dots\dots(i)$$

$$3\log_z y = 3 + 1 = 4 \Rightarrow \log_z y = \frac{4}{3}$$

$$y^3 = z^4 \quad \dots\dots(2)$$

$$7\log_x z = 3 + \frac{3}{2} = \frac{9}{2} \Rightarrow \log_x z = \frac{9}{14}$$

$$z^{14} = x^9 \quad \dots\dots(3)$$

Now

$$x^{pq^2} = x^{\frac{6}{7}qr} = x^{\frac{9p^2r}{14}}$$

$$pq^2 = \frac{6}{7}qr = \frac{9}{14}p^2r$$

$$pq = \frac{6}{7}r$$

$$q^2 = \frac{9}{14}pr$$

$$r = pq + 1$$

$$\Rightarrow q^3 = \frac{9}{14} \frac{6}{7} r \cdot r$$

$$\Rightarrow r = \frac{6}{7}r + 1$$

$$\Rightarrow \boxed{r=7}$$

$$\Rightarrow \boxed{q=3}$$

Now

$$r - p - q$$

$$= 7 - 2 - 3$$

$$= \boxed{2}$$

68. The relation $R = \{(a, b) : \gcd(a, b) = 1, 2a \neq b, a, b \in \mathbb{Z}\}$ is :

- (1) reflexive but not symmetric
 (2) transitive but not reflexive
 (3) symmetric but not transitive
 (4) neither symmetric nor transitive

Sol. (4)

$\gcd(a, b) = 1, 2a \neq b$

reflexive $\gcd(a, a) = a$ Not possible

symmetric $\gcd(b, a) = 1 \ \& \ 2a \neq b$ Not possible

$a = 2, b = 1$

transitive (a, b) = (2, 3) $\gcd\{a, b\} = 1, 2a \neq b$

(b, c) = (3, 4) $\gcd\{c, d\} = 1, 2a \neq c$

(a, c) = (2, 4) $\gcd\{2, 4\} = 2, 2a = c$

Not possible

69. Let PQR be a triangle. The points A, B and C are on the sides QR, RP and PQ respectively such that

$\frac{QA}{AR} = \frac{RB}{BP} = \frac{PC}{CQ} = \frac{1}{2}$. Then $\frac{\text{Area}(\Delta PQR)}{\text{Area}(\Delta ABC)}$ is equal to

(1) 4

(2) 3

(3)

(4) 2

Sol. (2)

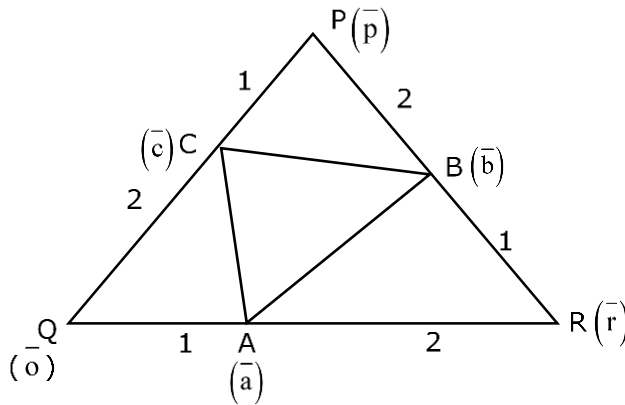

$$\vec{a} = \frac{\vec{r}}{3}$$

$$\vec{b} = \frac{\vec{b} + 2\vec{r}}{3}$$

$$\vec{c} = \frac{2\vec{p}}{3}$$

$\Delta PQR = \frac{1}{2} |\vec{r} \times \vec{p}|$

$\Delta ABC = \frac{1}{2} |\vec{a} \times \vec{b} + \vec{b} \times \vec{c} + \vec{c} \times \vec{a}|$

$= \frac{1}{2} \left| \frac{\vec{r} \times \vec{p}}{9} + \frac{4(\vec{r} \times \vec{p})}{9} + \frac{2}{9} \vec{p} \times \vec{r} \right|$

$= \frac{1}{18} |3(\vec{r} \times \vec{p})|$

Hence $\frac{|\Delta PQR|}{|\Delta ABC|} = 3$

70. Let $y = y(x)$ be the solution of the differential equation $x^3 dy + (xy - 1)dx = 0, x > 0, y\left(\frac{1}{2}\right) = 3 - e$.

Then $y(1)$ is equal to

(1) 1

(2) e

(3) 3

(4) 2 - e

Sol. (1)
 $x^3 dy + (xy - 1) dx = 0$

$$x^3 \frac{dy}{dx} = 1 - xy$$

$$x^3 \frac{dy}{dx} + xy = 1$$

$$\frac{dy}{dx} + \frac{y}{x^2} = \frac{1}{x^3} \Big|_{\text{LDE}}$$

$$\text{I.F} = e^{\int \frac{1}{x^2} dx} = e^{-\frac{1}{x}}$$

$$y \cdot e^{-\frac{1}{x}} = \int e^{-\frac{1}{x}} \cdot \frac{1}{x^3} dx$$

$$\frac{-1}{x} = t$$

$$= -\int e^t t dt$$

$$y \cdot e^{-\frac{1}{x}} = -e^t (t-1) + k$$

$$y \cdot e^{-\frac{1}{x}} = -e^{-\frac{1}{x}} \left(\frac{-1}{x} - 1 \right) + k$$

$$y = \left(\frac{1}{x} + 1 \right) + k e^{\frac{1}{x}}$$

$$\text{put } x = \frac{1}{2} \Rightarrow 3 - e = (2+1) + k e^2$$

$$k = -\frac{1}{e}$$

$$\text{Now } y(1) = 2 + \frac{-1}{e}$$

$$= \boxed{1}$$

71. If A and B are two non-zero $n \times n$ matrices such that $A^2 + B = A^2 B$, then

- (1) $A^2 = I$ or $B = I$ (2) $A^2 B = I$ (3) $AB = I$ (4) $A^2 B = BA^2$

Sol. (4)
 $A^2 + B = A^2 B$ (1)

$$A^2 - A^2 B + B = 0$$

$$A^2 - A^2 B - (I - B) = -I$$

$$(I - A^2) (I - B) = I$$

So,

$(I - A^2)$ & $(I - B)$ are inverses of each other

So

$$(I - B) (I - A^2) = I$$

$$I - B - A^2 + BA^2 = I$$

$$BA^2 = B + A^2$$
(2)

So, from (1) & (2)

$$A^2 B = BA^2$$

72. The equation $x^2 - 4x + [x] + 3 = x[x]$, where $[x]$ denotes the greatest integer function, has :
- (1) a unique solution in $(-\infty, 1)$ (2) no solution
(3) exactly two solutions in $(-\infty, \infty)$ (4) a unique solution in $(-\infty, \infty)$

Sol. (4)

$$x^2 - 4x + [x] + 3 = x[x]$$

$$x^2 - 4x + 3 = (x - 1)[x]$$

$$(x - 1)(x - 3) = (x - 1)[x]$$

$$\boxed{x=1} \text{ or } x - 3 = [x]$$

$$x - [x] = 3$$

$$\{x\} = 3$$

73. Let a tangent to the curve $y^2 = 24x$ meet the curve $xy = 2$ at the points A and B. Then the mid points of such line segments AB lie on a parabola with the
- (1) Length of latus rectum $\frac{3}{2}$ (2) directrix $4x = -3$
(3) length of latus rectum 2 (4) directrix $4x = 3$

Sol. (4)

$c_1 : y^2 = 24x$ & $c_2 : xy = 2$

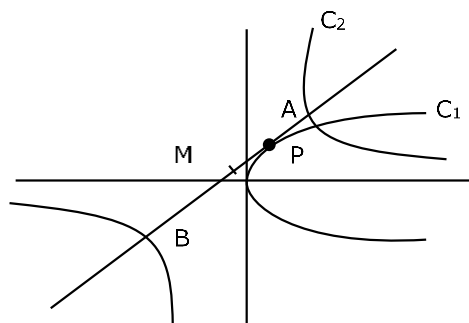

AB : [Tangent to parabola at p(t)]

$$ty = x + 6t^2 \quad \dots\dots(1)$$

AB : [chord with given mid point of hyperbola]

$T = S_1$

$$\frac{x}{h} + \frac{y}{k} = 2 \quad \dots\dots(2)$$

from (1) & (2)

$$\frac{-1}{h} = \frac{t}{1} = \frac{6t^2}{2}$$

$$-h = kt = 3t^2$$

$$h = -3t^2 \quad \& \quad k = 3t$$

$$h = -3\frac{k^2}{9} \Rightarrow \boxed{y^2 = -3x}$$

ℓ (LR) = 3 & directrix is $\boxed{x = \frac{3}{4}}$

74. Let Ω be the sample space and $A \subseteq \Omega$ be an event.

Given below are two statements :

(S1) : If $P(A) = 0$, then $A = \emptyset$

(S2): If $P(A) = 1$, then $A = \Omega$

Then

(1) both (S1) and (S2) are true

(2) only (S1) is true

(3) only (S2) is true

(4) both (S1) and (S2) are false

Sol. (4)

Let $\Omega = [0, 1]$

Let $A \rightarrow$ selecting $\frac{1}{2}$

$$A = \left\{ \frac{1}{2} \right\}$$

then, $P(A) = 0$ but $A \neq \emptyset$

$$B = A^c = [0,1] - \left\{ \frac{1}{2} \right\}$$

$P(B) = 1$

but $B \neq \Omega$

Ans = 4

75. The value of $\sum_{r=0}^{22} {}^{22}C_r \cdot {}^{23}C_r$ is

(1) ${}^{44}C_{23}$

(2) ${}^{45}C_{23}$

(3) ${}^{44}C_{22}$

(4) ${}^{45}C_{24}$

Sol. (2)

$$\sum_{r=0}^{22} {}^{22}C_r \cdot {}^{23}C_r$$

$$= \sum_{r=0}^{22} {}^{22}C_r \cdot {}^{23}C_r$$

$${}^{45}C_{22} = {}^{45}C_{23}$$

76. The distance of the point $(-1, 9, -16)$ from the plane $2x + 3y - z = 5$ measured parallel to the line

$$\frac{x+4}{3} = \frac{2-y}{4} = \frac{z-3}{12} \text{ is}$$

(1) 31

(2) $13\sqrt{2}$

(3) $20\sqrt{2}$

(4) 26

Sol. (4)

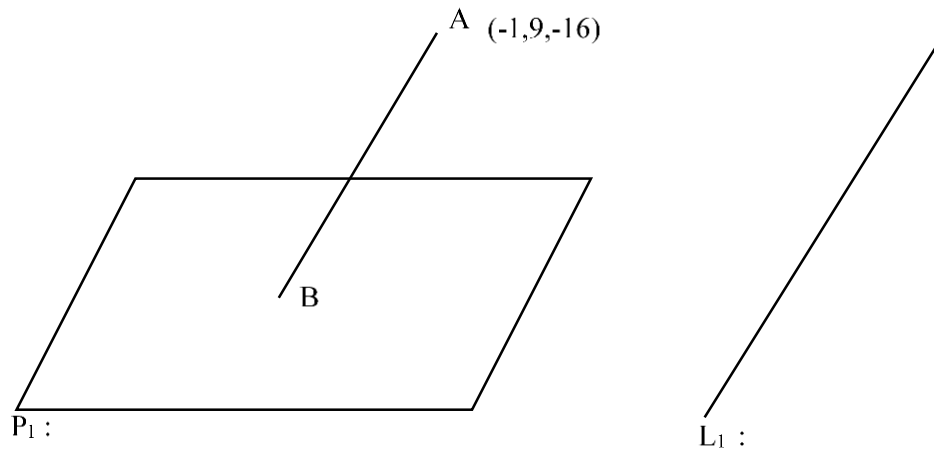

$$L_{AB} : \frac{x+1}{3} = \frac{y-9}{-4} = \frac{z+16}{12} = t$$

B : $(3t - 1, 9 - 4t, 12t - 16)$ lies on plane

$$2(3t - 1) + 3(9 - 4t) - (12t - 16) = 5$$

$$-18t - 2 + 27 + 16 = 5$$

$$-18t + 25 + 16 = 5$$

$$-18t = -36 \Rightarrow \boxed{t=2}$$

B : $(5, 1, 8)$ & A : $(-1, 9, -16)$

$$l(AB) = \sqrt{36 + 64 + 576} = \sqrt{676} = \boxed{26}$$

77. $\tan^{-1} \left(\frac{1+\sqrt{3}}{3+\sqrt{3}} \right) + \sec^{-1} \left(\sqrt{\frac{8+4\sqrt{3}}{6+3\sqrt{3}}} \right)$ is equal to :

(1) $\frac{\pi}{3}$

(2) $\frac{\pi}{4}$

(3) $\frac{\pi}{6}$

(4) $\frac{\pi}{2}$

Sol. (1)

$$\tan^{-1} \left(\frac{1+\sqrt{3}}{\sqrt{3}(1+\sqrt{3})} \right) + \sec^{-1} \left(\sqrt{\frac{8+4\sqrt{3}}{6+3\sqrt{3}}} \right)$$

$$= \tan^{-1} \left(\frac{1}{\sqrt{3}} \right) + \sec^{-1} \sqrt{\frac{4(2+\sqrt{3})}{3(2+\sqrt{3})}}$$

$$= \tan^{-1} \left(\frac{1}{\sqrt{3}} \right) + \sec^{-1} \frac{2}{\sqrt{3}}$$

$$= \frac{\pi}{6} + \frac{\pi}{6} = \boxed{\frac{\pi}{3}}$$

78. Let $f(x) = \begin{cases} x^2 \sin\left(\frac{1}{x}\right) & , x \neq 0 \\ 0 & , x = 0 \end{cases}$

Then at $x = 0$

- (1) f is continuous but not differentiable
- (2) f and f' both are continuous
- (3) f' is continuous but not differentiable
- (4) f is continuous but f' is not continuous

Sol. (4)

$$f(x) = \begin{cases} x^2 \sin \frac{1}{x} & x \neq 0 \\ 0 & x = 0 \end{cases}$$

→ cont. of $f(x)$ at $x = 0$

$$\left. \begin{aligned} \text{LHL} &= \lim_{h \rightarrow 0} h^2 \sin \frac{1}{(-h)} = 0 \\ \text{RHL} &= \lim_{h \rightarrow 0} h^2 \sin \frac{1}{(-h)} = 0 \\ f(0) &= 0 \end{aligned} \right\} \text{continuous at } x = 0$$

→ Diff. of $f(x)$ at $x = 0$

$$\text{RHD} = \lim_{h \rightarrow 0} \frac{h^2 \sin\left(\frac{1}{h}\right) - 0}{h} = \lim_{h \rightarrow 0} h \sin \frac{1}{h} = 0$$

$$\text{LHD} = \lim_{h \rightarrow 0} \frac{h^2 \sin\left(\frac{-1}{h}\right) - 0}{-h} = \lim_{h \rightarrow 0} h \sin \frac{1}{h} = 0$$

Hence $f(x)$ is diff. at $x = 0$

Now diff. $f(x)$ at $x = 0$

$$f'(x) = \begin{cases} 2x \sin\left(\frac{1}{x}\right) + x^2 \cos\left(\frac{1}{x}\right)\left(\frac{-1}{x^2}\right) & x \neq 0 \\ 0 & x = 0 \end{cases}$$

$$f'(x) = \begin{cases} 2x \sin\left(\frac{1}{x}\right) - \cos\left(\frac{1}{x}\right) & x \neq 0 \\ 0 & x = 0 \end{cases}$$

hence $f'(x)$ limit oscillate at $x = 0$

hence $f'(x)$ is D.C. at $\boxed{x = 0}$

79. The compound statement $(\sim (P \wedge Q)) \vee ((\sim P) \wedge Q) \Rightarrow ((\sim P) \wedge (\sim Q))$ is equivalent to

- (1) $(\sim Q) \vee P$
- (2) $((\sim P) \vee Q) \wedge (\sim Q)$
- (3) $(\sim P) \vee Q$
- (4) $((\sim P) \vee Q) \wedge ((\sim Q) \vee P)$

Sol. (4)

$$(\sim(p \wedge q) \vee (\sim p \wedge q)) \rightarrow \sim p \wedge \sim q$$

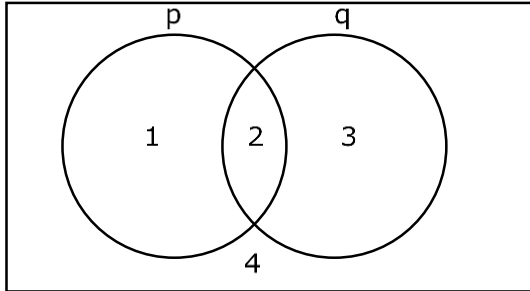

$$(1 + 2 + 4) + 2 \Rightarrow 4$$

$$(1 + 2 + 4) \Rightarrow 4 \quad = \sim(1 + 2 + 4) + 4 \\ = 3 + 4$$

Ans. $\boxed{4}$

80. The distance of the point $(7, -3, -4)$ from the plane passing through the points $(2, -3, 1)$, $(-1, 1, -2)$ and $(3, -4, 2)$ is :

(1) 5

(2) 4

(3) $5\sqrt{2}$

(4) $4\sqrt{2}$

Sol. (3)

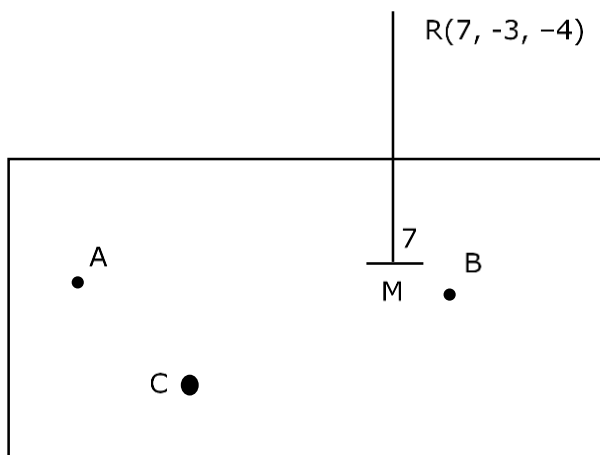

$$\vec{n}_p = \vec{AB} \times \vec{DC} = \begin{vmatrix} \hat{i} & \hat{j} & \hat{k} \\ 3 & -4 & 3 \\ -1 & 1 & -1 \end{vmatrix} = \langle 1, 0, -1 \rangle$$

Equation of plane P: $1(x - 2) + 0(y + 3) - (z - 1) = 0$

P: $x - z - 1 = 0$

$$d(RM) = \left| \frac{7 + 4 - 1}{\sqrt{2}} \right| = 5\sqrt{2}$$

SECTION - B

81. Let $\lambda \in \mathbb{R}$ and let the equation E be $|x|^2 - 2|x| + |\lambda - 3| = 0$. Then the largest element in the set $S = \{x + \lambda : x \text{ is an integer solution of E}\}$ is

Sol. **5**

$$|x|^2 - 2|x| + |\lambda - 3| = 0$$

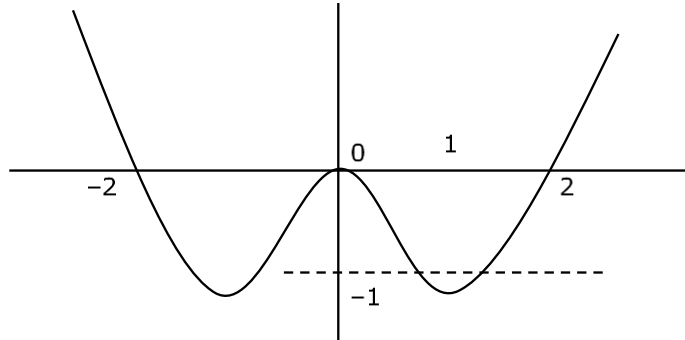

$$|x|^2 - 2|x| = -|\lambda - 3|$$

$$\begin{array}{l} \text{LHS} = -1 \leq |x|^2 - 2|x| < \infty \\ \text{RHS} = -|\lambda - 3| \leq 0 \end{array}$$

Now LHS = RHS only when

$$0 \leq |\lambda - 3| \leq 1 \quad \& \quad \boxed{x \in [-2, 2]}$$

$$-1 \leq \lambda - 3 \leq 1$$

$$\boxed{2 \leq \lambda \leq 4}$$

82. Let a tangent to the curve $9x^2 + 16y^2 = 144$ intersect the coordinate axes at the points A and B. Then, the minimum length of the line segment AB is

Sol. **7**

$$\frac{x^2}{16} + \frac{y^2}{9} = 1$$

Elipse

$$\text{Let } P = (4\cos\theta, 3\sin\theta)$$

$$\text{Tp: } \frac{x}{4} \cos\theta + \frac{y}{3} \sin\theta = 1$$

$$\text{A: } (0, 3\operatorname{cosec}\theta), \text{ B: } (4\sec\theta, 0)$$

$$\ell(\text{AB}) = \sqrt{16\sec^2\theta + 9\operatorname{cosec}^2\theta}$$

$$= \sqrt{16 + 9 + (4\tan\theta - 3\cot\theta)^2 + 24}$$

$$\ell(\text{AB})_{\min} = 7$$

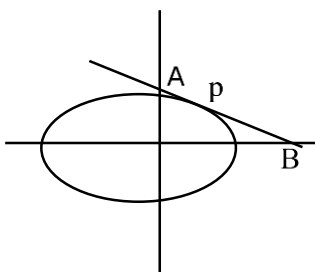

83. The shortest distance between the lines $\frac{x-2}{3} = \frac{y+1}{2} = \frac{z-6}{2}$ and $\frac{x-6}{3} = \frac{1-y}{2} = \frac{z+8}{0}$ is equal to

Sol. 14

$$L_1 : \bar{a} = \langle 2, -1, 6 \rangle \quad L_2 : \bar{b} = \langle 6, 1, -8 \rangle$$

$$\bar{p} = \langle 3, 2, 2 \rangle \quad \bar{q} = \langle 3, -2, 0 \rangle$$

$$\bar{p} \times \bar{q} = \begin{vmatrix} \hat{i} & \hat{j} & \hat{k} \\ 3 & 2 & 2 \\ 3 & -2 & 0 \end{vmatrix} = \langle 4, 6, -12 \rangle \quad (\text{s.f.})$$

$$= \langle 2, 3, -6 \rangle$$

$$b\Delta = \frac{|(\bar{b} - \bar{a}) \cdot |\bar{p} \times \bar{q}||}{|\bar{p} \times \bar{q}|}$$

$$= \frac{|(4\hat{i} + 2\hat{j} - 14\hat{k}) \cdot (2\hat{i} + 3\hat{j} - 6\hat{k})|}{\sqrt{4 + 9 + 36}}$$

$$= \frac{|8 + 6 + 84|}{\sqrt{49}} = \frac{|98|}{7} = \boxed{14}$$

84. Suppose $\sum_{r=0}^{2023} r^2 \cdot {}^{2023}C_r = 2023 \times \alpha \times 2^{2022}$. Then the value of α is

Sol. (1012)

$$\sum_{r=0}^n r^2 \cdot {}^n C_r$$

$$= \sum_{r=0}^n r^2 \cdot \frac{n}{r} \cdot {}^{n-1} C_{r-1}$$

$$= n \sum_{r=1}^n \left((r-1)^{n-1} C_{r-1} + {}^{n-1} C_{r-1} \right)$$

$$= n \sum_{r=2}^n (n-1)^{n-2} C_{r-2} + n \sum_{r=1}^n {}^{n-1} C_{r-1}$$

$$= n(n-1) [2^{n-2}] + n [2^{n-1}]$$

$$= 2023 \cdot 2022 \cdot 2^{2021} + 2023 \cdot 2^{2022}$$

$$= 2023 \cdot 2^{2021} [2022 + 2]$$

$$= 2023 \cdot 2^{2021} \cdot 2024$$

$$= 2023 \cdot 1012 \cdot 2^{2022} \Rightarrow \alpha = 1012$$

85. The value of $\frac{8}{\pi} \int_0^{\frac{\pi}{2}} \frac{(\cos x)^{2023}}{(\sin x)^{2023} + (\cos x)^{2023}} dx$ is

Sol. (2)

$$I = \frac{8}{\pi} \int_0^{\frac{\pi}{2}} \frac{(\cos x)^{2023}}{(\sin x)^{2023} + (\cos x)^{2023}} dx$$

\downarrow KJ&A

$$2I = \frac{8}{\pi} \int_0^{\frac{\pi}{2}} 1 dx$$

$$2I = \frac{8}{\pi} \cdot \frac{\pi}{2} \Rightarrow I = 2$$

86. The number of 9 digit numbers, that can be formed using all the digits of the number 123412341 so that the even digits occupy only even places, is

Sol. (60)

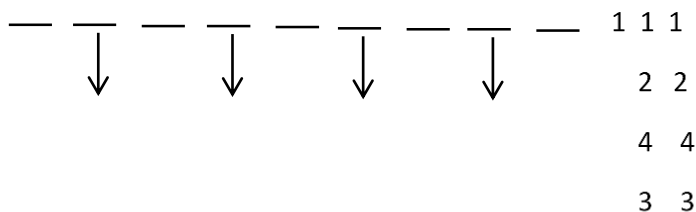

4 even place can be occupied by 4 even digits

$$\text{No of ways} = \frac{4!}{2!2!} = 6$$

Odd place can be occupied by 5 odd digits

$$\text{No of ways} = \frac{5!}{3!2!} = 10$$

$$\text{Total no.} = 6 \times 10 = 60$$

87. A boy needs to select five courses from 12 available courses, out of which 5 courses are language courses. If he can choose at most two language courses, then the number of ways he can choose five courses is

Sol. (546)

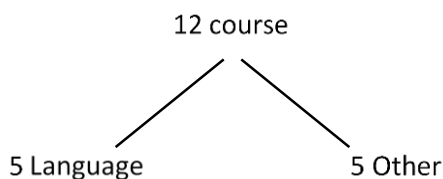

$$(0 \text{ language} + 5 \text{ other}) + (1 \text{ Language} + 4 \text{ other}) + (2 \text{ Language} + 3 \text{ other})$$

$$= {}^5C_0 \cdot {}^7C_5 + {}^5C_1 \cdot {}^7C_4 + {}^5C_2 \cdot {}^7C_3$$

$$= 21 + 175 + 350$$

$$= 546$$

88. The 4th term of GP is 500 and its common ratio is $\frac{1}{m}$, $m \in \mathbb{N}$. Let S_n denote the sum of the first n terms of this GP. If $S_6 > S_5 + 1$ and $S_7 < S_6 + \frac{1}{2}$, then the number of possible values of m is

Sol. (12)

$$T_4 = 500 \Rightarrow a \left(\frac{1}{m} \right)^3 = 500 \Rightarrow a = 500 m^3$$

$$\text{Now } S_n - S_{n-1} = a \left(\frac{1-r^n}{1-r} \right) - a \left(\frac{1-r^{n-1}}{1-r} \right)$$

$$= \frac{a}{1-r} [r^{n-1}(1-r)]$$

$$= a r^{n-1}$$

$$= 500 m^3 \left(\frac{1}{m} \right)^{n-1}$$

$$S_n - S_{n-1} = 500 m^{4-n}$$

$$\text{Now } S_6 - S_5 > 1 \Rightarrow 500 m^{-2} > 1 \dots (1)$$

$$\& S_7 - S_6 < \frac{1}{2} \Rightarrow 500 m^{-3} < \frac{1}{2} \dots (2)$$

$$\left. \begin{array}{l} \text{from (1)} \quad m^2 < 500 \\ \text{from (2)} \quad m^3 > 1000 \end{array} \right\} 10 < m \leq 22$$

Number of possible values of m is = 12

89. Let C be the largest circle centred at (2,0) and inscribed in the ellipse $\frac{x^2}{36} + \frac{y^2}{16} = 1$.

If (1, α) lies on C, then $10\alpha^2$ is equal to

Sol. (118)

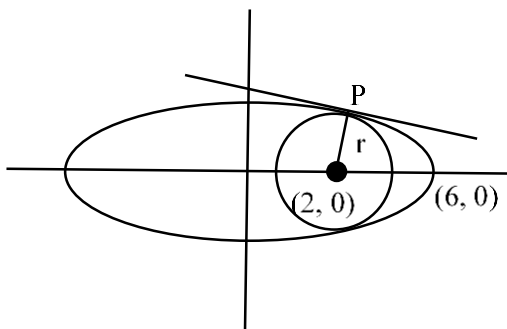

$$E: \frac{x^2}{36} + \frac{y^2}{16} = 1 \quad \& \quad C: (x-2)^2 + y^2 = r^2$$

For largest circle r is maximum

$$P(6\cos\theta, 4\sin\theta)$$

$$N_P: 6x \sec\theta - 4y \operatorname{cosec}\theta = 20 \text{ pass } (2, 0)$$

$$12 \sec\theta = 20 \Rightarrow \cos\theta = \frac{3}{5}$$

$$\text{Now } P: \left(6 \times \frac{3}{5}, 4 \times \frac{4}{5} \right) \Rightarrow P: \left(\frac{18}{5}, \frac{16}{5} \right)$$

$$r = \sqrt{\left(2 - \frac{18}{5}\right)^2 + \left(\frac{16}{5}\right)^2}$$

$$r = \frac{\sqrt{64 + 256}}{5} = \frac{8\sqrt{5}}{5} = \frac{8}{\sqrt{5}}$$

$$C: = (x - 2)^2 + y^2 = \frac{64}{5}$$

Now $(1, \alpha)$ lies on C

$$\Rightarrow (1 - 2)^2 + \alpha^2 = \frac{64}{5}$$

$$\alpha^2 = \frac{64}{5} - 1$$

$$\alpha^2 = \frac{59}{5} \Rightarrow 10\alpha^2 = 118$$

90. The value of $12 \int_0^3 |x^2 - 3x + 2| dx$ is

Sol. (22)

$$I = 12 \int_0^3 |x^2 - 3x + 2| dx$$

$$I = 12 \int_0^3 |(x - 2)(x - 1)| dx$$

$$= 12 \left[\int_0^1 (x^2 - 3x + 2) + \int_1^2 -(x^2 - 3x + 2) + \int_2^3 (x^2 - 3x + 2) \right]$$

$$= 12 \left[\left(\frac{1}{3} - \frac{3}{2} + 2 \right) - \left(\frac{7}{3} - \frac{9}{2} + 2 \right) + \left(\frac{19}{3} - \frac{15}{2} + 2 \right) \right]$$

$$= 12 \left[\frac{5}{6} + \frac{1}{6} + \frac{5}{6} \right]$$

$$= \frac{12 \cdot 11}{6}$$

$$= 22$$