

FINAL JEE-MAIN EXAMINATION – JANUARY, 2024

(Held On Wednesday 31st January, 2024)

TIME : 3 : 00 PM to 6 : 00 PM

MATHEMATICS

TEST PAPER WITH SOLUTION

SECTION-A

1. The number of ways in which 21 identical apples can be distributed among three children such that each child gets at least 2 apples, is

- (1) 406
- (2) 130
- (3) 142
- (4) 136

Ans. (4)

Sol. After giving 2 apples to each child 15 apples left now 15 apples can be distributed in ${}^{15+3-1}C_2 = {}^{17}C_2$ ways

$$= \frac{17 \times 16}{2} = 136$$

2. Let A (a, b), B(3, 4) and (-6, -8) respectively denote the centroid, circumcentre and orthocentre of a triangle. Then, the distance of the point P(2a + 3, 7b + 5) from the line $2x + 3y - 4 = 0$ measured parallel to the line $x - 2y - 1 = 0$ is

- (1) $\frac{15\sqrt{5}}{7}$
- (2) $\frac{17\sqrt{5}}{6}$
- (3) $\frac{17\sqrt{5}}{7}$
- (4) $\frac{\sqrt{5}}{17}$

Ans. (3)

Sol. A(a,b), B(3,4), C(-6, -8)

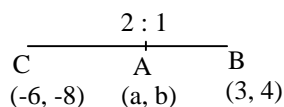

$$\Rightarrow a = 0, b = 0 \Rightarrow P(3, 5)$$

Distance from P measured along $x - 2y - 1 = 0$

$$\Rightarrow x = 3 + r \cos \theta, y = 5 + r \sin \theta$$

Where $\tan \theta = \frac{1}{2}$

$$r(2 \cos \theta + 3 \sin \theta) = -17$$

$$\Rightarrow r = \left| \frac{-17\sqrt{5}}{7} \right| = \frac{17\sqrt{5}}{7}$$

3. Let z_1 and z_2 be two complex number such that $z_1 + z_2 = 5$ and $z_1^3 + z_2^3 = 20 + 15i$. Then $|z_1^4 + z_2^4|$ equals-

- (1) $30\sqrt{3}$
- (2) 75
- (3) $15\sqrt{15}$
- (4) $25\sqrt{3}$

Ans. (2)

Sol.- $z_1 + z_2 = 5$

$$z_1^3 + z_2^3 = 20 + 15i$$

$$z_1^3 + z_2^3 = (z_1 + z_2)^3 - 3z_1z_2(z_1 + z_2)$$

$$z_1^3 + z_2^3 = 125 - 3z_1z_2(5)$$

$$\Rightarrow 20 + 15i = 125 - 15z_1z_2$$

$$\Rightarrow 3z_1z_2 = 25 - 4 - 3i$$

$$\Rightarrow 3z_1z_2 = 21 - 3i$$

$$\Rightarrow z_1z_2 = 7 - i$$

$$\Rightarrow (z_1 + z_2)^2 = 25$$

$$\Rightarrow z_1^2 + z_2^2 = 25 - 2(7 - i)$$

$$\Rightarrow 11 + 2i$$

$$(z_1^2 + z_2^2)^2 = 121 - 4 + 44i$$

$$\Rightarrow z_1^4 + z_2^4 + 2(7 - i)^2 = 117 + 44i$$

$$\Rightarrow z_1^4 + z_2^4 = 117 + 44i - 2(49 - 1 - 14i)$$

$$\Rightarrow |z_1^4 + z_2^4| = 75$$

4. Let a variable line passing through the centre of the circle $x^2 + y^2 - 16x - 4y = 0$, meet the positive co-ordinate axes at the point A and B. Then the minimum value of OA + OB, where O is the origin, is equal to

- (1) 12
- (2) 18
- (3) 20
- (4) 24

Ans. (2)

Sol.- $(y - 2) = m(x - 8)$

\Rightarrow x-intercept

$$\Rightarrow \left(\frac{-2}{m} + 8 \right)$$

\Rightarrow y-intercept

$$\Rightarrow (-8m + 2)$$

$$\Rightarrow OA + OB = \frac{-2}{m} + 8 - 8m + 2$$

$$f'(m) = \frac{2}{m^2} - 8 = 0$$

$$\Rightarrow m^2 = \frac{1}{4}$$

$$\Rightarrow m = \frac{-1}{2}$$

$$\Rightarrow f\left(\frac{-1}{2}\right) = 18$$

\Rightarrow Minimum = 18

5. Let $f, g: (0, \infty) \rightarrow \mathbb{R}$ be two functions defined by

$$f(x) = \int_{-x}^x (|t| - t^2) e^{-t^2} dt \text{ and } g(x) = \int_0^{x^2} t^{1/2} e^{-t} dt.$$

Then the value of $\left(f\left(\sqrt{\log_e 9}\right) + g\left(\sqrt{\log_e 9}\right) \right)$ is equal to

- (1) 6
- (2) 9
- (3) 8
- (4) 10

Ans. (3)

Sol.-

$$f(x) = \int_{-x}^x (|t| - t^2) e^{-t^2} dt$$

$$\Rightarrow f'(x) = 2 \cdot (|x| - x^2) e^{-x^2} \dots \dots \dots (1)$$

$$g(x) = \int_0^{x^2} t^{1/2} e^{-t} dt$$

$$g'(x) = x e^{-x^2} (2x) - 0$$

$$f'(x) + g'(x) = 2x e^{-x^2} - 2x^2 e^{-x^2} + 2x^2 e^{-x^2}$$

Integrating both sides w.r.t.x

$$f(x) + g(x) = \int_0^x 2x e^{-x^2} dx$$

$$x^2 = t$$

$$\Rightarrow \int_0^{\sqrt{\alpha}} e^{-t} dt = \left[-e^{-t} \right]_0^{\sqrt{\alpha}}$$

$$= -e^{-(\log_e(9)^{-1})+1}$$

$$\Rightarrow 9(f(x) + g(x)) = \left(1 - \frac{1}{9}\right) 9 = 8$$

6. Let (α, β, γ) be mirror image of the point $(2, 3, 5)$

in the line $\frac{x-1}{2} = \frac{y-2}{3} = \frac{z-3}{4}$.

Then $2\alpha + 3\beta + 4\gamma$ is equal to

- (1) 32
- (2) 33
- (3) 31
- (4) 34

Ans. (2)

Sol.

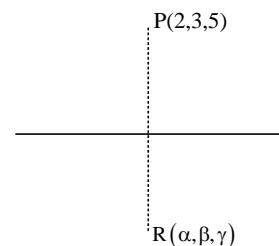

$$\therefore \overline{PR} \perp (2, 3, 4)$$

$$\therefore \overline{PR} \cdot (2, 3, 4) = 0$$

$$(\alpha - 2, \beta - 3, \gamma - 5) \cdot (2, 3, 4) = 0$$

$$\Rightarrow 2\alpha + 3\beta + 4\gamma = 4 + 9 + 20 = 33$$

7. Let P be a parabola with vertex (2, 3) and directrix $2x + y = 6$. Let an ellipse $E: \frac{x^2}{a^2} + \frac{y^2}{b^2} = 1, a > b$ of eccentricity $\frac{1}{\sqrt{2}}$ pass through the focus of the parabola P. Then the square of the length of the latus rectum of E, is

- (1) $\frac{385}{8}$
- (2) $\frac{347}{8}$
- (3) $\frac{512}{25}$
- (4) $\frac{656}{25}$

Ans. (4)

Sol.-

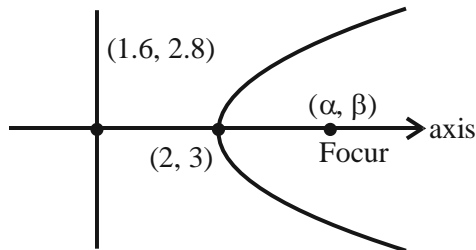

Slope of axis = $\frac{1}{2}$

$$y - 3 = \frac{1}{2}(x - 2)$$

$$\Rightarrow 2y - 6 = x - 2$$

$$\Rightarrow 2y - x - 4 = 0$$

$$2x + y - 6 = 0$$

$$4x + 2y - 12 = 0$$

$$\alpha + 1.6 = 4 \Rightarrow \alpha = 2.4$$

$$\beta + 2.8 = 6 \Rightarrow \beta = 3.2$$

Ellipse passes through (2.4, 3.2)

$$\Rightarrow \frac{\left(\frac{24}{10}\right)^2}{a^2} + \frac{\left(\frac{32}{10}\right)^2}{b^2} = 1 \dots\dots\dots(1)$$

Also $1 - \frac{b^2}{a^2} = \frac{1}{2} = \frac{b^2}{a^2} = \frac{1}{2}$

$$\Rightarrow a^2 = 2b^2$$

Put in (1) $\Rightarrow b^2 = \frac{328}{25}$

$$\Rightarrow \left(\frac{2b^2}{a}\right)^2 = \frac{4b^2}{a^2} \times b^2 = 4 \times \frac{1}{2} \times \frac{328}{25} = \frac{656}{25}$$

8. The temperature $T(t)$ of a body at time $t = 0$ is $160^\circ F$ and it decreases continuously as per the differential equation $\frac{dT}{dt} = -K(T - 80)$, where K is positive constant. If $T(15) = 120^\circ F$, then $T(45)$ is equal to

- (1) $85^\circ F$
- (2) $95^\circ F$
- (3) $90^\circ F$
- (4) $80^\circ F$

Ans. (3)

Sol.-

$$\frac{dT}{dt} = -k(T - 80)$$

$$\int_{160}^T \frac{dT}{(T - 80)} = \int_0^t -K dt$$

$$[\ln|T - 80|]_{160}^T = -kt$$

$$\ln|T - 80| - \ln 80 = -kt$$

$$\ln \left| \frac{T - 80}{80} \right| = -kt$$

$$T = 80 + 80e^{-kt}$$

$$120 = 80 + 80e^{-k \cdot 15}$$

$$\frac{40}{80} = e^{-k \cdot 15} = \frac{1}{2}$$

$$\therefore T(45) = 80 + 80e^{-k \cdot 45}$$

$$= 80 + 80(e^{-k \cdot 15})^3$$

$$= 80 + 80 \times \frac{1}{8}$$

$$= 90$$

9. Let 2^{nd} , 8^{th} and 44^{th} terms of a non-constant A.P. be respectively the 1^{st} , 2^{nd} and 3^{rd} terms of G.P. If the first term of A.P. is 1 then the sum of first 20 terms is equal to-

- (1) 980 (2) 960
(3) 990 (4) 970

Ans. (4)

Sol.- $1 + d, 1 + 7d, 1 + 43d$ are in GP

$$(1 + 7d)^2 = (1 + d)(1 + 43d)$$

$$1 + 49d^2 + 14d = 1 + 44d + 43d^2$$

$$6d^2 - 30d = 0$$

$$d = 5$$

$$S_{20} = \frac{20}{2} [2 \times 1 + (20-1) \times 5]$$

$$= 10 [2 + 95]$$

$$= 970$$

10. Let $f: \mathbb{R} \rightarrow (0, \infty)$ be strictly increasing function such that $\lim_{x \rightarrow \infty} \frac{f(7x)}{f(x)} = 1$. Then, the value

of $\lim_{x \rightarrow \infty} \left[\frac{f(5x)}{f(x)} - 1 \right]$ is equal to

- (1) 4
(2) 0
(3) $7/5$
(4) 1

Ans. (2)

Sol.- $f: \mathbb{R} \rightarrow (0, \infty)$

$$\lim_{x \rightarrow \infty} \frac{f(7x)}{f(x)} = 1$$

$\therefore f$ is increasing

$$\therefore f(x) < f(5x) < f(7x)$$

$$\therefore \frac{f(x)}{f(x)} < \frac{f(5x)}{f(x)} < \frac{f(7x)}{f(x)}$$

$$1 < \lim_{x \rightarrow \infty} \frac{f(5x)}{f(x)} < 1$$

$$\therefore \left[\frac{f(5x)}{f(x)} - 1 \right]$$

$$\Rightarrow 1 - 1 = 0$$

11. The area of the region enclosed by the parabola $y = 4x - x^2$ and $3y = (x - 4)^2$ is equal to

- (1) $\frac{32}{9}$
(2) 4
(3) 6
(4) $\frac{14}{3}$

Ans. (3)

Sol.-

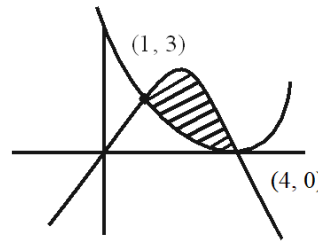

$$\text{Area} = \left| \int_1^4 \left[(4x - x^2) - \frac{(x-4)^2}{3} \right] dx \right|$$

$$\text{Area} = \left| \frac{4x^2}{2} - \frac{x^3}{3} - \frac{(x-4)^3}{9} \right|_1^4$$

$$= \left| \left(\frac{64}{2} - \frac{64}{3} - \frac{4}{2} + \frac{1}{3} - \frac{27}{9} \right) \right|$$

$$\Rightarrow (27 - 21) = 6$$

12. Let the mean and the variance of 6 observation $a, b, 68, 44, 48, 60$ be 55 and 194, respectively if $a > b$, then $a + 3b$ is

- (1) 200
(2) 190
(3) 180
(4) 210

Ans. (3)

Sol.- $a, b, 68, 44, 48, 60$

$$\text{Mean} = 55 \quad a > b$$

$$\text{Variance} = 194 \quad a + 3b$$

$$\frac{a + b + 68 + 44 + 48 + 60}{6} = 55$$

$$\Rightarrow 220 + a + b = 330$$

$$\therefore a + b = 110 \dots (1)$$

Also,

$$\sum \frac{(x_i - \bar{x})^2}{n} = 194$$

$$\Rightarrow (a-55)^2 + (b-55)^2 + (68-55)^2 + (44-55)^2$$

$$+ (48-55)^2 + (60-55)^2 = 194 \times 6$$

$$\Rightarrow (a-55)^2 + (b-55)^2 + 169 + 121 + 49 + 25 = 1164$$

$$\Rightarrow (a-55)^2 + (b-55)^2 = 1164 - 364 = 800$$

$$a^2 + 3025 - 110a + b^2 + 3025 - 110b = 800$$

$$\Rightarrow a^2 + b^2 = 800 - 6050 + 12100$$

$$a^2 + b^2 = 6850 \dots \dots (2)$$

Solve (1) & (2);

$$a=75, b=35$$

$$\therefore a + 3b = 75 + 3(35) = 75 + 105 = 180$$

13. If the function $f : (-\infty, -1] \rightarrow (a, b]$ defined by $f(x) = e^{x^3 - 3x + 1}$ is one-one and onto, then the distance of the point $P(2b + 4, a + 2)$ from the line $x + e^{-3}y = 4$ is :

- (1) $2\sqrt{1+e^6}$ (2) $4\sqrt{1+e^6}$
 (3) $3\sqrt{1+e^6}$ (4) $\sqrt{1+e^6}$

Ans. (1)

Sol.- $f(x) = e^{x^3 - 3x + 1}$

$$f'(x) = e^{x^3 - 3x + 1} \cdot (3x^2 - 3)$$

$$= e^{x^3 - 3x + 1} \cdot 3(x-1)(x+1)$$

For $f'(x) \geq 0$

$\therefore f(x)$ is increasing function

$$\therefore a = e^{-\infty} = 0 = f(-\infty)$$

$$b = e^{-1+3+1} = e^3 = f(-1)$$

$$P(2b + 4, a + 2)$$

$$\therefore P(2e^3 + 4, 2)$$

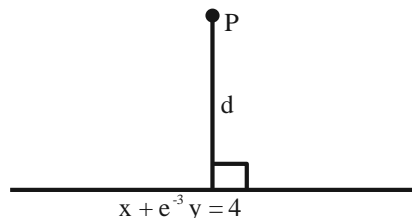

$$d = \frac{(2e^3 + 4) + 2e^{-3} - 4}{\sqrt{1 + e^{-6}}} = 2\sqrt{1 + e^6}$$

14. Consider the function $f : (0, \infty) \rightarrow \mathbb{R}$ defined by $f(x) = e^{-|\log_e x|}$. If m and n be respectively the number of points at which f is not continuous and f is not differentiable, then $m + n$ is

- (1) 0
 (2) 3
 (3) 1
 (4) 2

Ans. (3)

Sol.-

$$f : (0, \infty) \rightarrow \mathbb{R}$$

$$f(x) = e^{-|\log_e x|}$$

$$f(x) = \frac{1}{e^{|\ln x|}} = \begin{cases} \frac{1}{e^{-\ln x}}; 0 < x < 1 \\ \frac{1}{e^{\ln x}}; x \geq 1 \end{cases}$$

$$\begin{cases} \frac{1}{x} = x; 0 < x < 1 \\ \frac{1}{x} \\ \frac{1}{x}, x \geq 1 \end{cases}$$

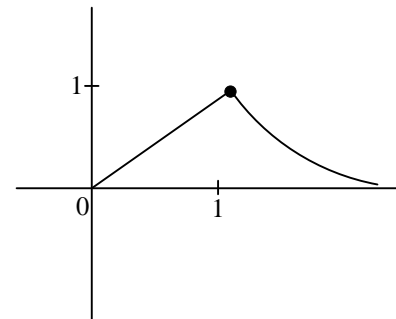

$m = 0$ (No point at which function is not continuous)

$n = 1$ (Not differentiable)

$$\therefore m + n = 1$$

15. The number of solutions, of the equation $e^{\sin x} - 2e^{-\sin x} = 2$ is

- (1) 2
 (2) more than 2
 (3) 1
 (4) 0

Ans. (4)

Sol.- Take $e^{\sin x} = t (t > 0)$

$$\Rightarrow t - \frac{2}{t} = 2$$

$$\Rightarrow \frac{t^2 - 2}{t} = 2$$

$$\Rightarrow t^2 - 2t - 2 = 0$$

$$\Rightarrow t^2 - 2t + 1 = 3$$

$$\Rightarrow (t-1)^2 = 3$$

$$\Rightarrow t = 1 \pm \sqrt{3}$$

$$\Rightarrow t = 1 \pm 1.73$$

$$\Rightarrow t = 2.73 \text{ or } -0.73 \text{ (rejected as } t > 0)$$

$$\Rightarrow e^{\sin x} = 2.73$$

$$\Rightarrow \log_e e^{\sin x} = \log_e 2.73$$

$$\Rightarrow \sin x = \log_e 2.73 > 1$$

So no solution.

16. If $a = \sin^{-1}(\sin(5))$ and $b = \cos^{-1}(\cos(5))$,

then $a^2 + b^2$ is equal to

(1) $4\pi^2 + 25$

(2) $8\pi^2 - 40\pi + 50$

(3) $4\pi^2 - 20\pi + 50$

(4) 25

Ans. (2)

Sol. $a = \sin^{-1}(\sin 5) = 5 - 2\pi$

and $b = \cos^{-1}(\cos 5) = 2\pi - 5$

$$\therefore a^2 + b^2 = (5 - 2\pi)^2 + (2\pi - 5)^2$$

$$= 8\pi^2 - 40\pi + 50$$

17. If for some m, n ; ${}^6C_m + 2({}^6C_{m+1}) + {}^6C_{m+2} > {}^8C_3$

and ${}^{n-1}P_3 : {}^n P_4 = 1 : 8$, then ${}^n P_{m+1} + {}^{n+1} C_m$ is equal

to

(1) 380

(2) 376

(3) 384

(4) 372

Ans. (4)

Sol.- ${}^6C_m + 2({}^6C_{m+1}) + {}^6C_{m+2} > {}^8C_3$

$${}^7C_{m+1} + {}^7C_{m+2} > {}^8C_3$$

$${}^8C_{m+2} > {}^8C_3$$

$$\therefore m = 2$$

And ${}^{n-1}P_3 : {}^n P_4 = 1 : 8$

$$\frac{(n-1)(n-2)(n-3)}{n(n-1)(n-2)(n-3)} = \frac{1}{8}$$

$$\therefore n = 8$$

$$\therefore {}^n P_{m+1} + {}^{n+1} C_m = {}^8 P_3 + {}^9 C_2$$

$$= 8 \times 7 \times 6 + \frac{9 \times 8}{2}$$

$$= 372$$

18. A coin is biased so that a head is twice as likely to occur as a tail. If the coin is tossed 3 times, then the probability of getting two tails and one head is-

(1) $\frac{2}{9}$

(2) $\frac{1}{9}$

(3) $\frac{2}{27}$

(4) $\frac{1}{27}$

Ans. (1)

Sol. Let probability of tail is $\frac{1}{3}$

$$\Rightarrow \text{Probability of getting head} = \frac{2}{3}$$

\therefore Probability of getting 2 tails and 1 head

$$= \left(\frac{1}{3} \times \frac{2}{3} \times \frac{1}{3} \right) \times 3$$

$$= \frac{2}{27} \times 3$$

$$= \frac{2}{9}$$

19. Let A be a 3 × 3 real matrix such that

$$A \begin{pmatrix} 1 \\ 0 \\ 1 \end{pmatrix} = 2 \begin{pmatrix} 1 \\ 0 \\ 1 \end{pmatrix}, A \begin{pmatrix} -1 \\ 0 \\ 1 \end{pmatrix} = 4 \begin{pmatrix} -1 \\ 0 \\ 1 \end{pmatrix}, A \begin{pmatrix} 0 \\ 1 \\ 0 \end{pmatrix} = 2 \begin{pmatrix} 0 \\ 1 \\ 0 \end{pmatrix}.$$

Then, the system $(A - 3I) \begin{pmatrix} x \\ y \\ z \end{pmatrix} = \begin{pmatrix} 1 \\ 2 \\ 3 \end{pmatrix}$ has

- (1) unique solution
- (2) exactly two solutions
- (3) no solution
- (4) infinitely many solutions

Ans. (1)

Sol.- Let $A = \begin{bmatrix} x_1 & y_1 & z_1 \\ x_2 & y_2 & z_2 \\ x_3 & y_3 & z_3 \end{bmatrix}$

$$\text{Given } A \begin{bmatrix} 1 \\ 0 \\ 1 \end{bmatrix} = \begin{bmatrix} 2 \\ 0 \\ 2 \end{bmatrix} \quad \dots (1)$$

$$\therefore \begin{bmatrix} x_1 + z_1 \\ x_2 + z_2 \\ x_3 + z_3 \end{bmatrix} = \begin{bmatrix} 2 \\ 0 \\ 2 \end{bmatrix}$$

$$\therefore x_1 + z_1 = 2 \quad \dots (2)$$

$$x_2 + z_2 = 0 \quad \dots (3)$$

$$x_3 + z_3 = 0 \quad \dots (4)$$

$$\text{Given } A \begin{bmatrix} -1 \\ 0 \\ 1 \end{bmatrix} = \begin{bmatrix} -4 \\ 0 \\ 4 \end{bmatrix}$$

$$\therefore \begin{bmatrix} -x_1 + z_1 \\ -x_2 + z_2 \\ -x_3 + z_3 \end{bmatrix} = \begin{bmatrix} 4 \\ 0 \\ 4 \end{bmatrix}$$

$$\Rightarrow -x_1 + z_1 = 4 \quad \dots (5)$$

$$-x_2 + z_2 = 0 \quad \dots (6)$$

$$-x_3 + z_3 = 4$$

$$\text{Given } A \begin{bmatrix} 0 \\ 1 \\ 0 \end{bmatrix} = \begin{bmatrix} 0 \\ 2 \\ 0 \end{bmatrix}$$

$$\therefore \begin{bmatrix} y_1 \\ y_2 \\ y_3 \end{bmatrix} = \begin{bmatrix} 0 \\ 2 \\ 0 \end{bmatrix}$$

$$\therefore y_1 = 0, y_2 = 2, y_3 = 0$$

\(\therefore\) from (2), (3), (4), (5), (6) and (7)

$$x_1 = 3x, x_2 = 0, x_3 = -1$$

$$y_1 = 0, y_2 = 2, y_3 = 0$$

$$z_1 = -1, z_2 = 0, z_3 = 3$$

$$\therefore A = \begin{bmatrix} 3 & 0 & -1 \\ 0 & 2 & 0 \\ -1 & 0 & 3 \end{bmatrix}$$

$$\therefore \text{Now } (A - 3I) \begin{bmatrix} x \\ y \\ z \end{bmatrix} = \begin{bmatrix} -1 \\ 2 \\ 3 \end{bmatrix}$$

$$\therefore \begin{bmatrix} 0 & 0 & -1 \\ 0 & -1 & 0 \\ -1 & 0 & 0 \end{bmatrix} \begin{bmatrix} x \\ y \\ z \end{bmatrix} = \begin{bmatrix} -1 \\ 2 \\ 3 \end{bmatrix}$$

$$\begin{bmatrix} -z \\ -y \\ -x \end{bmatrix} = \begin{bmatrix} 1 \\ 2 \\ 3 \end{bmatrix}$$

$$[z = -1], [y = -2], [x = -3]$$

20. The shortest distance between lines L_1 and L_2 ,

where $L_1 : \frac{x-1}{2} = \frac{y+1}{-3} = \frac{z+4}{2}$ and L_2 is the line

passing through the points $A(-4, 4, 3)$ and $B(-1, 6, 3)$

and perpendicular to the line $\frac{x-3}{-2} = \frac{y}{3} = \frac{z-1}{1}$, is

$$(1) \frac{121}{\sqrt{221}} \quad (2) \frac{24}{\sqrt{117}}$$

$$(3) \frac{141}{\sqrt{221}} \quad (4) \frac{42}{\sqrt{117}}$$

Ans. (3)

Sol.-

$$L_2 = \frac{x+4}{3} = \frac{y-4}{2} = \frac{z-3}{0}$$

$$\therefore \text{S.D} = \frac{\begin{vmatrix} x_2 - x_1 & y_2 - y_1 & z_2 - z_1 \\ 2 & -3 & 2 \\ 3 & 2 & 0 \end{vmatrix}}{|\vec{n}_1 \times \vec{n}_2|}$$

$$= \frac{\begin{vmatrix} 5 & -5 & -7 \\ 2 & -3 & 2 \\ 3 & 2 & 0 \end{vmatrix}}{|\vec{n}_1 \times \vec{n}_2|}$$

$$= \frac{141}{|-4\hat{i} + 6\hat{j} + 13\hat{k}|}$$

$$= \frac{141}{\sqrt{16 + 36 + 169}}$$

$$= \frac{141}{\sqrt{221}}$$

SECTION-B

21. $\left| \frac{120}{\pi^3} \int_0^\pi \frac{x^2 \sin x \cos x}{\sin^4 x + \cos^4 x} dx \right|$ is equal to _____.

Ans. (15)

Sol.- $\int_0^\pi \frac{x^2 \sin x \cdot \cos x}{\sin^4 x + \cos^4 x} dx$

$$= \int_0^{\frac{\pi}{2}} \frac{\sin x \cdot \cos x}{\sin^4 x + \cos^4 x} (x^2 - (\pi - x)^2) dx$$

$$= \int_0^{\frac{\pi}{2}} \frac{\sin x \cdot \cos x (2\pi x - \pi^2)}{\sin^4 x + \cos^4 x} dx$$

$$= 2\pi \int_0^{\frac{\pi}{2}} \frac{x \sin x \cos x}{\sin^4 x + \cos^4 x} dx - \pi^2 \int_0^{\frac{\pi}{2}} \frac{\sin x \cos x}{\sin^4 x + \cos^4 x} dx$$

$$= 2\pi \cdot \frac{\pi}{4} \int_0^{\frac{\pi}{2}} \frac{\sin x \cos x}{\sin^4 x + \cos^4 x} dx - \pi^2 \int_0^{\frac{\pi}{2}} \frac{\sin x \cos x}{\sin^4 x + \cos^4 x} dx$$

$$= -\frac{\pi^2}{2} \int_0^{\frac{\pi}{2}} \frac{\sin x \cos x}{\sin^4 x + \cos^4 x} dx$$

$$= -\frac{\pi^2}{2} \int_0^{\frac{\pi}{2}} \frac{\sin x \cos x dx}{1 - 2\sin^2 x \times \cos^2 x}$$

$$= -\frac{\pi^2}{2} \int_0^{\frac{\pi}{2}} \frac{\sin 2x}{2 - \sin^2 2x} dx$$

$$= -\frac{\pi^2}{2} \int_0^{\frac{\pi}{2}} \frac{\sin 2x}{1 + \cos^2 2x} dx$$

Let $\cos 2x = t$

22. Let a, b, c be the length of three sides of a triangle satisfying the condition $(a^2 + b^2)x^2 - 2b(a + c)x + (b^2 + c^2) = 0$. If the set of all possible values of x is the interval (α, β) , then $12(\alpha^2 + \beta^2)$ is equal to _____.

Ans. (36)

Sol.- $(a^2 + b^2)x^2 - 2b(a + c)x + b^2 + c^2 = 0$

$$\Rightarrow a^2x^2 - 2abx + b^2 + b^2x^2 - 2bcx + c^2 = 0$$

$$\Rightarrow (ax - b)^2 + (bx - c)^2 = 0$$

$$\Rightarrow ax - b = 0, \quad bx - c = 0$$

$$\Rightarrow a + b > c \quad b + c > a \quad c + a > b$$

$$a + ax > bx \quad \left| \begin{array}{l} ax + bx > a \\ ax^2 + a > ax \end{array} \right.$$

$$a + ax > ax^2 \quad \left| \begin{array}{l} ax + ax^2 > a \\ x^2 - x + 1 > 0 \end{array} \right.$$

$$x^2 - x - 1 < 0 \quad \left| \begin{array}{l} x^2 + x - 1 > 0 \\ \text{always true} \end{array} \right.$$

$$\frac{1 - \sqrt{5}}{2} < x < \frac{1 + \sqrt{5}}{2}$$

$$x < \frac{-1 - \sqrt{5}}{2}, \quad \text{or } x > \frac{-1 + \sqrt{5}}{2}$$

$$\Rightarrow \frac{\sqrt{5}-1}{2} < x < \frac{\sqrt{5}+1}{2}$$

$$\Rightarrow \alpha = \frac{\sqrt{5}-1}{2}, \beta = \frac{\sqrt{5}+1}{2}$$

$$12(\alpha^2 + \beta^2) = 12 \left(\frac{(\sqrt{5}-1)^2 + (\sqrt{5}+1)^2}{4} \right) = 36$$

23. Let A(-2, -1), B(1, 0), C(α, β) and D(γ, δ) be the vertices of a parallelogram ABCD. If the point C lies on 2x - y = 5 and the point D lies on 3x - 2y = 6, then the value of |α + β + γ + δ| is equal to _____.

Ans. (32)

Sol.-

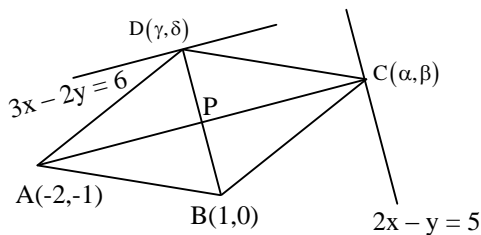

$$P \equiv \left(\frac{\alpha-2}{2}, \frac{\beta-1}{2} \right) \equiv \left(\frac{\gamma+1}{2}, \frac{\delta}{2} \right)$$

$$\frac{\alpha-2}{2} = \frac{\gamma+1}{2} \text{ and } \frac{\beta-1}{2} = \frac{\delta}{2}$$

$$\Rightarrow \alpha - \gamma = 3 \dots (1), \quad \beta - \delta = 1 \dots (2)$$

Also, (γ, δ) lies on 3x - 2y = 6

$$3\gamma - 2\delta = 6 \dots (3)$$

and (α, β) lies on 2x - y = 5

$$\Rightarrow 2\alpha - \beta = 5 \dots (4)$$

Solving (1), (2), (3), (4)

$$\alpha = -3, \beta = -11, \gamma = -6, \delta = -12$$

$$|\alpha + \beta + \gamma + \delta| = 32$$

24. Let the coefficient of x^r in the expansion of

$$(x+3)^{n-1} + (x+3)^{n-2}(x+2) +$$

$$(x+3)^{n-3}(x+2)^2 + \dots + (x+2)^{n-1}$$

be α_r . If $\sum_{r=0}^n \alpha_r = \beta^n - \gamma^n$, $\beta, \gamma \in \mathbb{N}$, then the value of $\beta^2 + \gamma^2$ equals _____.

Ans. (25)

Sol.-

$$(x+3)^{n-1} + (x+3)^{n-2}(x+2) + (x+3)^{n-3}$$

$$(x+2)^2 + \dots + (x+2)^{n-1}$$

$$\sum \alpha_r = 4^{n-1} + 4^{n-2} \times 3 + 4^{n-3} \times 3^2 + \dots + 3^{n-1}$$

$$= 4^{n-1} \left[1 + \frac{3}{4} + \left(\frac{3}{4}\right)^2 + \dots + \left(\frac{3}{4}\right)^{n-1} \right]$$

$$= 4^{n-1} \times \frac{1 - \left(\frac{3}{4}\right)^n}{1 - \frac{3}{4}}$$

$$= 4^n - 3^n = \beta^n - \gamma^n$$

$$\beta = 4, \gamma = 3$$

$$\beta^2 + \gamma^2 = 16 + 9 = 25$$

25. Let A be a 3×3 matrix and $\det(A) = 2$. If

$$n = \det \left(\underbrace{\text{adj}(\text{adj}(\dots(\text{adj}A)))}_{2024\text{-times}} \right)$$

Then the remainder when n is divided by 9 is equal to _____.

Ans. (7)

Sol.- $|A| = 2$

$$\underbrace{\text{adj}(\text{adj}(\dots(a)))}_{2024\text{ times}} = |A|^{(n-1)2024}$$

$$= |A|^{2 \cdot 2024}$$

$$= 2^{2 \cdot 2024}$$

$$2^{2024} = (2^2)^{2^{2022}} = 4(8)^{674} = 4(9-1)^{674}$$

$$\Rightarrow 2^{2024} \equiv 4 \pmod{9}$$

$$\Rightarrow 2^{2024} \equiv 9m+4, \quad m \leftarrow \text{even}$$

$$2^{9m+4} \equiv 16 \cdot (2^3)^{3m} \equiv 16 \pmod{9}$$

$$\equiv 7$$

26. Let $\vec{a} = 3\hat{i} + 2\hat{j} + \hat{k}$, $\vec{b} = 2\hat{i} - \hat{j} + 3\hat{k}$ and \vec{c} be a vector such that $(\vec{a} + \vec{b}) \times \vec{c} = 2(\vec{a} \times \vec{b}) + 24\hat{j} - 6\hat{k}$ and $(\vec{a} - \vec{b} + \hat{i}) \cdot \vec{c} = -3$. Then $|\vec{c}|^2$ is equal to _____.

Ans. (38)

$$\text{Sol.- } (\vec{a} + \vec{b}) \times \vec{c} = 2(\vec{a} \times \vec{b}) + 24\hat{j} - 6\hat{k}$$

$$(5\hat{i} + \hat{j} + 4\hat{k}) \times \vec{c} = 2(7\hat{i} - 7\hat{j} - 7\hat{k}) + 24\hat{j} - 6\hat{k}$$

$$\begin{vmatrix} \hat{i} & \hat{j} & \hat{k} \\ 5 & 1 & 4 \\ x & y & z \end{vmatrix} = 14\hat{i} + 10\hat{j} - 20\hat{k}$$

$$\Rightarrow \hat{i}(z-4y) - \hat{j}(5z-4x) + \hat{k}(5y-x) = 14\hat{i} + 10\hat{j} - 20\hat{k}$$

$$z-4y=14, 4x-5z=10, 5y-x=-20$$

$$(a-b+i) \cdot \vec{c} = -3$$

$$(2\hat{i} + 3\hat{j} - 2\hat{k}) \cdot \vec{c} = -3$$

$$2x+3y-2z=-3$$

$$\therefore x=5, y=-3, z=2$$

$$|\vec{c}|^2 = 25+9+4=38$$

27. If $\lim_{x \rightarrow 0} \frac{ax^2e^x - b \log_e(1+x) + cxe^{-x}}{x^2 \sin x} = 1$,

then $16(a^2 + b^2 + c^2)$ is equal to _____.

Ans. (81)

$$\begin{aligned} & ax^2 \left(1+x + \frac{x^2}{2!} + \frac{x^3}{3!} + \dots \right) - b \left(x - \frac{x^2}{2} + \frac{x^3}{3} - \dots \right) \\ & + cx \left(1-x + \frac{x^2}{x!} - \frac{x^3}{3!} + \dots \right) \end{aligned}$$

Sol.-

$$\lim_{x \rightarrow 0} \frac{x^3 \cdot \frac{\sin x}{x}}{x^3} = \lim_{x \rightarrow \infty} \frac{(c-b)x + \left(\frac{b}{2} - c + a\right)x^2 + \left(a - \frac{b}{3} + \frac{c}{2}\right)x^3 + \dots}{x^3} = 1$$

$$c-b=0, \quad \frac{b}{2} - c + a = 0$$

$$a - \frac{b}{3} + \frac{c}{2} = 1 \quad a = \frac{3}{4} \quad b = c = \frac{3}{2}$$

$$a^2 + b^2 + c^2 = \frac{9}{16} + \frac{9}{4} + \frac{9}{4}$$

$$16(a^2 + b^2 + c^2) = 81$$

28. A line passes through A(4, -6, -2) and B(16, -2, 4). The point P(a, b, c) where a, b, c are non-negative integers, on the line AB lies at a distance of 21 units, from the point A. The distance between the points P(a, b, c) and Q(4, -12, 3) is equal to _____.

Ans. (22)

Sol.-

$$\frac{x-4}{12} = \frac{y+6}{4} = \frac{z+2}{6}$$

$$\frac{x-4}{6} = \frac{y+6}{2} = \frac{z+2}{3} = 21$$

$$\left(21 \times \frac{6}{7} + 4, \frac{2}{7} \times 21 - 6, \frac{3}{7} \times 21 - 2 \right)$$

$$= (22, 0, 7) = (a, b, c)$$

$$\therefore \sqrt{324+144+16} = 22$$

29. Let $y = y(x)$ be the solution of the differential equation

$$\sec^2 x dx + (e^{2y} \tan^2 x + \tan x) dy = 0,$$

$$0 < x < \frac{\pi}{2}, y\left(\frac{\pi}{4}\right) = 0. \text{ If } y\left(\frac{\pi}{6}\right) = \alpha,$$

Then $e^{8\alpha}$ is equal to _____.

Ans. (9)

Sol.-

$$\sec^2 x \frac{dx}{dy} + e^{2y} \tan^2 x + \tan x = 0$$

$$\left(\text{Put } \tan x = t \Rightarrow \sec^2 x \frac{dx}{dy} = \frac{dt}{dy} \right)$$

$$\frac{dt}{dy} + e^{2y} \times t^2 + t = 0$$

$$\frac{dt}{dy} + t = -t^2 \cdot e^{2y}$$

$$\frac{1}{t^2} \frac{dt}{dy} + \frac{1}{t} = -e^{2y}$$

$$\left(\text{Put } \frac{1}{t} = u \quad \frac{-1}{t^2} \frac{dt}{dy} = \frac{du}{dy} \right)$$

$$\frac{-du}{dy} + u = -e^{2y}$$

$$\frac{du}{dy} - u = e^{2y}$$

$$\text{I.F.} = e^{-\int dy} = e^{-y}$$

$$ue^{-y} = \int e^{-y} \times e^{2y} dy$$

$$\frac{1}{\tan x} \times e^{-y} = e^y + c$$

$$x = \frac{\pi}{4}, y = 0, c = 0$$

$$x = \frac{\pi}{6}, y = \alpha$$

$$\sqrt{3}e^{-\alpha} = e^{\alpha} + 0$$

$$e^{2\alpha} = \sqrt{3}$$

$$e^{8\alpha} = 9$$

30. Let $A = \{1, 2, 3, \dots, 100\}$. Let R be a relation on A defined by $(x, y) \in R$ if and only if $2x = 3y$. Let R_1 be a symmetric relation on A such that $R \subset R_1$ and the number of elements in R_1 is n . Then, the minimum value of n is _____.

Ans. (66)

Sol.-

$$R = \{(3, 2), (6, 4), (9, 6), (12, 8), \dots, (99, 66)\}$$

$$n(R) = 33$$

$$\therefore 66$$

34. Force between two point charges q_1 and q_2 placed in vacuum at 'r' cm apart is F. Force between them when placed in a medium having dielectric $K = 5$ at 'r/5' cm apart will be:

- (1) $F/25$ (2) $5F$
 (3) $F/5$ (4) $25F$

Ans. (2)

Sol. In air $F = \frac{1}{4\pi\epsilon_0} \frac{q_1q_2}{r^2}$

In medium

$$F' = \frac{1}{4\pi(K\epsilon_0)} \frac{q_1q_2}{(r')^2} = \frac{25}{4\pi(5\epsilon_0)} \frac{q_1q_2}{(r)^2} = 5F$$

35. An AC voltage $V = 20\sin 200\pi t$ is applied to a series LCR circuit which drives a current

$$I = 10 \sin\left(200\pi t + \frac{\pi}{3}\right). \text{ The average power}$$

dissipated is:

- (1) 21.6 W (2) 200 W
 (3) 173.2 W (4) 50 W

Ans. (4)

Sol. $\langle P \rangle = IV \cos \phi$

$$= \frac{20}{\sqrt{2}} \times \frac{10}{\sqrt{2}} \times \cos 60^\circ$$

$$= 50 \text{ W}$$

36. When unpolarized light is incident at an angle of 60° on a transparent medium from air. The reflected ray is completely polarized. The angle of refraction in the medium is

- (1) 30° (2) 60°
 (3) 90° (4) 45°

Ans. (1)

Sol. By Brewster's law

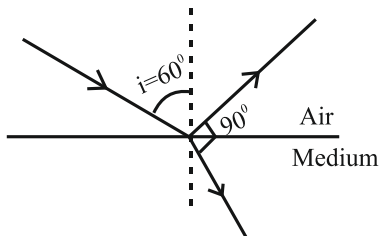

At complete reflection refracted ray and reflected ray are perpendicular.

37. The speed of sound in oxygen at S.T.P. will be approximately:

(Given, $R = 8.3 \text{ JK}^{-1}$, $\gamma = 1.4$)

- (1) 310 m/s
 (2) 333 m/s
 (3) 341 m/s
 (4) 325 m/s

Ans. (1)

Sol. $v = \sqrt{\frac{\gamma RT}{M}} = \sqrt{\frac{1.4 \times 8.3 \times 273}{32 \times 10^{-3}}}$
 $= 314.8541 \approx 315 \text{ m/s}$

38. A gas mixture consists of 8 moles of argon and 6 moles of oxygen at temperature T. Neglecting all vibrational modes, the total internal energy of the system is

- (1) 29 RT
 (2) 20 RT
 (3) 27 RT
 (4) 21 RT

Ans. (3)

Sol. $U = nC_V T$

$$\Rightarrow U = n_1 C_{V1} T + n_2 C_{V2} T$$

$$\Rightarrow 8 \times \frac{3R}{2} \times T + 6 \times \frac{5R}{2} \times T$$

$$= 27RT$$

39. The resistance per centimeter of a meter bridge wire is r, with $X \Omega$ resistance in left gap. Balancing length from left end is at 40 cm with 25 Ω resistance in right gap. Now the wire is replaced by another wire of 2r resistance per centimeter. The new balancing length for same settings will be at

- (1) 20 cm
 (2) 10 cm
 (3) 80 cm
 (4) 40 cm

Ans. (4)

Sol.

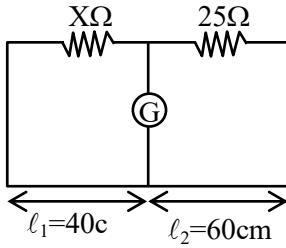

$$\frac{25}{r l_1} = \frac{X}{r l_2} \quad \dots (i)$$

$$\frac{25}{2r l'_1} = \frac{X}{2r l'_2} \quad \dots (ii)$$

From (i) and (ii)
 $l'_2 = l_2 = 40 \text{ cm}$

40. Given below are two statements:

Statement I: Electromagnetic waves carry energy as they travel through space and this energy is equally shared by the electric and magnetic fields.

Statement II: When electromagnetic waves strike a surface, a pressure is exerted on the surface.

In the light of the above statements, choose the most appropriate answer from the options given below:

- (1) Statement I is incorrect but Statement II is correct
- (2) Both Statement I and Statement II are correct.
- (3) Both Statement I and Statement II are incorrect.
- (4) Statement I is correct but Statement II is incorrect.

Ans. (2)

Sol. $\frac{1}{2} \epsilon_0 E^2 = \frac{B^2}{2\mu_0}$

$$\because E = CB \text{ and } C = \frac{1}{\mu_0 \epsilon_0}$$

41. In a photoelectric effect experiment a light of frequency 1.5 times the threshold frequency is made to fall on the surface of photosensitive material. Now if the frequency is halved and intensity is doubled, the number of photo electrons emitted will be:

- (1) Doubled
- (2) Quadrupled
- (3) Zero
- (4) Halved

Ans. (3)

Sol. Since $\frac{f}{2} < f_0$ i.e. the incident frequency is less than threshold frequency. Hence there will be no emission of photoelectrons.
 $\Rightarrow \text{current} = 0$

42. A block of mass 5 kg is placed on a rough inclined surface as shown in the figure.

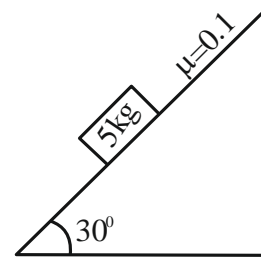

If \vec{F}_1 is the force required to just move the block up the inclined plane and \vec{F}_2 is the force required to just prevent the block from sliding down, then the value of $|\vec{F}_1| - |\vec{F}_2|$ is : [Use $g = 10 \text{ m/s}^2$]

- (1) $25\sqrt{3} \text{ N}$
- (2) $50\sqrt{3} \text{ N}$
- (3) $\frac{5\sqrt{3}}{2} \text{ N}$
- (4) 10 N

Ans. ($5\sqrt{3} \text{ N}$) BONUS

Sol. $f_K = \mu mg \cos \theta$

$$= 0.1 \times \frac{50 \times \sqrt{3}}{2}$$

$$= 2.5\sqrt{3} \text{ N}$$

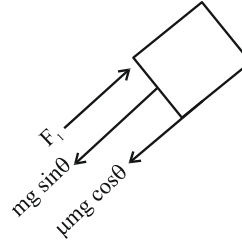

$$F_1 = mg \sin \theta + f_K$$

$$= 25 + 2.5\sqrt{3}$$

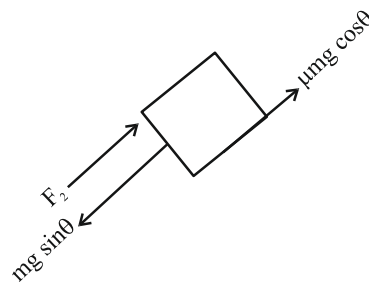

$$F_2 = mg \sin \theta - f_K$$

$$= 25 - 2.5\sqrt{3}$$

$$\therefore F_1 - F_2 = 5\sqrt{3} \text{ N}$$

43. By what percentage will the illumination of the lamp decrease if the current drops by 20%?

- (1) 46% (2) 26%
 (3) 36% (4) 56%

Ans. (3)

Sol. $P = i^2 R$

$$P_{\text{int}} = I_{\text{int}}^2 R$$

$$P_{\text{final}} = (0.8 I_{\text{int}})^2 R$$

% change in power =

$$\frac{P_{\text{final}} - P_{\text{int}}}{P_{\text{int}}} \times 100 = (0.64 - 1) \times 100 = -36\%$$

44. If two vectors \vec{A} and \vec{B} having equal magnitude R are inclined at an angle θ , then

$$(1) |\vec{A} - \vec{B}| = \sqrt{2} R \sin\left(\frac{\theta}{2}\right)$$

$$(2) |\vec{A} + \vec{B}| = 2 R \sin\left(\frac{\theta}{2}\right)$$

$$(3) |\vec{A} + \vec{B}| = 2 R \cos\left(\frac{\theta}{2}\right)$$

$$(4) |\vec{A} - \vec{B}| = 2 R \cos\left(\frac{\theta}{2}\right)$$

Ans. (3)

Sol. The magnitude of resultant vector

$$R' = \sqrt{a^2 + b^2 + 2ab \cos \theta}$$

Here $a = b = R$

$$\text{Then } R' = \sqrt{R^2 + R^2 + 2R^2 \cos \theta}$$

$$= R\sqrt{2} \sqrt{1 + \cos \theta}$$

$$= \sqrt{2} R \sqrt{2 \cos^2 \frac{\theta}{2}}$$

$$= 2R \cos \frac{\theta}{2}$$

45. The mass number of nucleus having radius equal to half of the radius of nucleus with mass number 192 is:

- (1) 24 (2) 32
 (3) 40 (4) 20

Ans. (1)

$$\text{Sol. } R_1 = \frac{R_2}{2}$$

$$R_0 (A_1)^{1/3} = \frac{R_0}{2} (A_2)^{1/3}$$

$$A_1 = \frac{1}{8} A_2$$

$$A_1 = \frac{192}{8} = 24$$

46. The mass of the moon is 1/144 times the mass of a planet and its diameter 1/16 times the diameter of a planet. If the escape velocity on the planet is v , the escape velocity on the moon will be:

$$(1) \frac{v}{3} \quad (2) \frac{v}{4}$$

$$(3) \frac{v}{12} \quad (4) \frac{v}{6}$$

Ans. (1)

$$\text{Sol. } V_{\text{escape}} = \sqrt{\frac{2GM}{R}}$$

$$V_{\text{planet}} = \sqrt{\frac{2GM}{R}} = v$$

$$V_{\text{Moon}} = \sqrt{\frac{2GM \times 16}{144 R}} = \frac{1}{3} \sqrt{\frac{2GM}{R}}$$

$$V_{\text{Moon}} = \frac{V_{\text{Planet}}}{3} = \frac{v}{3}$$

47. A small spherical ball of radius r , falling through a viscous medium of negligible density has terminal velocity ' v '. Another ball of the same mass but of radius $2r$, falling through the same viscous medium will have terminal velocity:

$$(1) \frac{v}{2} \quad (2) \frac{v}{4}$$

$$(3) 4v \quad (4) 2v$$

Ans. (1)

Sol. Since density is negligible hence Buoyancy force will be negligible

At terminal velocity.

$$Mg = 6\pi\eta r v$$

$$V \propto \frac{1}{r} \quad (\text{as mass is constant})$$

$$\text{Now, } \frac{v}{v'} = \frac{r'}{r}$$

$$r' = 2r$$

$$\text{So, } v' = \frac{v}{2}$$

48. A body of mass 2 kg begins to move under the action of a time dependent force given by $\vec{F} = (6t \hat{i} + 6t^2 \hat{j})\text{N}$. The power developed by the force at the time t is given by:

- (1) $(6t^4 + 9t^5)\text{W}$
- (2) $(3t^3 + 6t^5)\text{W}$
- (3) $(9t^5 + 6t^3)\text{W}$
- (4) $(9t^3 + 6t^5)\text{W}$

Ans. (4)

Sol. $\vec{F} = (6t \hat{i} + 6t^2 \hat{j})\text{N}$

$$\vec{F} = m\vec{a} = (6t\hat{i} + 6t^2\hat{j})$$

$$\vec{a} = \frac{\vec{F}}{m} = (3t\hat{i} + 3t^2\hat{j})$$

$$\vec{v} = \int_0^t \vec{a} dt = \frac{3t^2}{2} \hat{i} + t^3 \hat{j}$$

$$P = \vec{F} \cdot \vec{v} = (9t^3 + 6t^5)\text{W}$$

49.

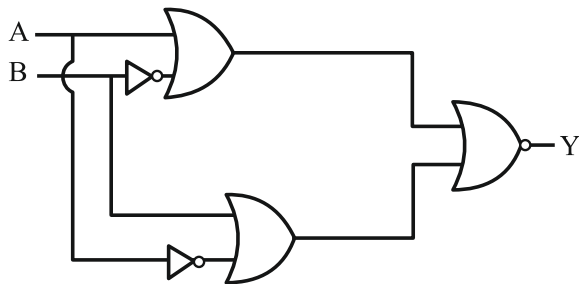

The output of the given circuit diagram is

- | A | B | Y |
|---|---|---|
| 0 | 0 | 0 |
| 1 | 0 | 0 |
| 0 | 1 | 0 |
| 1 | 1 | 1 |
- | A | B | Y |
|---|---|---|
| 0 | 0 | 0 |
| 1 | 0 | 1 |
| 0 | 1 | 1 |
| 1 | 1 | 0 |
- | A | B | Y |
|---|---|---|
| 0 | 0 | 0 |
| 1 | 0 | 0 |
| 0 | 1 | 0 |
| 1 | 1 | 0 |
- | A | B | Y |
|---|---|---|
| 0 | 0 | 0 |
| 1 | 0 | 0 |
| 0 | 1 | 1 |
| 1 | 1 | 0 |

Ans. (3)

Sol.

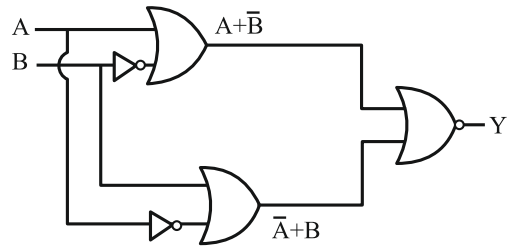

$$\text{If } A = 0; \bar{A} = 1$$

$$A = 1; \bar{A} = 0$$

$$B = 0; \bar{B} = 1$$

$$B = 1; \bar{B} = 0$$

$$Y = \overline{(A + \bar{B})} + \overline{(\bar{A} + B)} = \overline{(1+1)} = 0$$

50. Consider two physical quantities A and B related to each other as $E = \frac{B - x^2}{At}$ where E, x and t have dimensions of energy, length and time respectively. The dimension of AB is

- (1) $L^{-2}M^1T^0$
- (2) $L^2M^{-1}T^1$
- (3) $L^{-2}M^{-1}T^1$
- (4) $L^0M^{-1}T^1$

Ans. (2)

Sol. $[B] = L^2$

$$A = \frac{x^2}{tE} = \frac{L^2}{TML^2T^{-2}} = \frac{1}{MT^{-1}}$$

$$[A] = M^{-1}T$$

$$[AB] = [L^2M^{-1}T^1]$$

SECTION-B

51. In the following circuit, the battery has an emf of 2 V and an internal resistance of $\frac{2}{3} \Omega$. The power consumption in the entire circuit is _____ W.

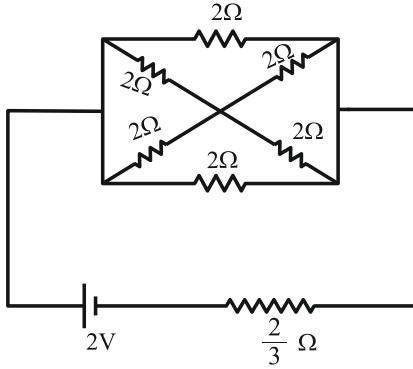

Ans. (3)

Sol. $R_{eq} = \frac{4}{3} \Omega$
 $\therefore P = \frac{V^2}{R_{eq}} = \frac{4}{4/3} = 3 \text{ W}$

52. Light from a point source in air falls on a convex curved surface of radius 20 cm and refractive index 1.5. If the source is located at 100 cm from the convex surface, the image will be formed at _____ cm from the object.

Ans. (200)

Sol.

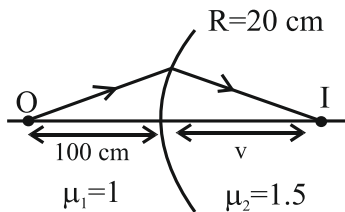

$$\frac{\mu_2}{v} - \frac{\mu_1}{u} = \frac{\mu_2 - \mu_1}{R}$$

$$\frac{1.5}{v} - \frac{1}{-100} = \frac{1.5 - 1}{20}$$

$$v = 100 \text{ cm}$$

Distance from object
 $= 100 + 100$
 $= 200 \text{ cm}$

53. The magnetic flux ϕ (in weber) linked with a closed circuit of resistance 8Ω varies with time (in seconds) as $\phi = 5t^2 - 36t + 1$. The induced current in the circuit at $t = 2\text{s}$ is _____ A.

Ans. (2)

Sol. $\epsilon = -\left(\frac{d\phi}{dt}\right) = 10t - 36$
 at $t = 2, \epsilon = 16 \text{ V}$
 $i = \frac{\epsilon}{R} = \frac{16}{8} = 2 \text{ A}$

54. Two blocks of mass 2 kg and 4 kg are connected by a metal wire going over a smooth pulley as shown in figure. The radius of wire is $4.0 \times 10^{-5} \text{ m}$ and Young's modulus of the metal is $2.0 \times 10^{11} \text{ N/m}^2$. The longitudinal strain developed in the wire is $\frac{1}{\alpha\pi}$. The value of α is _____. [Use $g = 10 \text{ m/s}^2$]

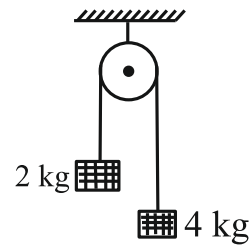

Ans. (12)

Sol. $T = \left(\frac{2m_1m_2}{m_1 + m_2}\right)g = \frac{80}{3} \text{ N}$
 $A = \pi r^2 = 16\pi \times 10^{-10} \text{ m}^2$
 $\text{Strain} = \frac{\Delta l}{l} = \frac{F}{AY} = \frac{T}{AY}$
 $= \frac{80/3}{16\pi \times 10^{-10} \times 2 \times 10^{11}} = \frac{1}{12\pi}$
 $\alpha = 12$

55. A body of mass 'm' is projected with a speed 'u' making an angle of 45° with the ground. The angular momentum of the body about the point of projection, at the highest point is expressed as $\frac{\sqrt{2} \mu u^3}{Xg}$. The value of 'X' is _____.

Ans. (8)

Sol.

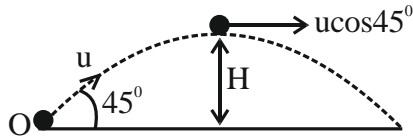

$$L = mu \cos \theta \frac{u^2 \sin^2 \theta}{2g}$$

$$= mu^3 \frac{1}{4\sqrt{2}g} \Rightarrow x = 8$$

56. Two circular coils P and Q of 100 turns each have same radius of π cm. The currents in P and R are 1 A and 2 A respectively. P and Q are placed with their planes mutually perpendicular with their centers coincide. The resultant magnetic field induction at the center of the coils is \sqrt{x} mT, where $x =$ _____.

[Use $\mu_0 = 4\pi \times 10^{-7} \text{ TmA}^{-1}$]

Ans. (20)

Sol.

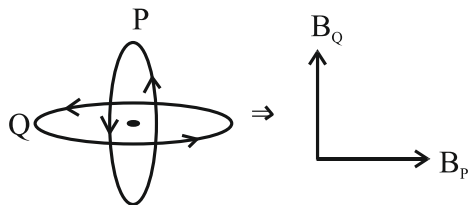

$$B_P = \frac{\mu_0 N i_1}{2r} = \frac{\mu_0 \times 1 \times 100}{2\pi} = 2 \times 10^{-3} \text{ T}$$

$$B_Q = \frac{\mu_0 N i_2}{2r} = \frac{\mu_0 \times 2 \times 100}{2\pi} = 4 \times 10^{-3} \text{ T}$$

$$B_{\text{net}} = \sqrt{B_P^2 + B_Q^2}$$

$$= \sqrt{20} \text{ mT}$$

$$x = 20$$

57. The distance between charges $+q$ and $-q$ is $2l$ and between $+2q$ and $-2q$ is $4l$. The electrostatic potential at point P at a distance r from centre O is $-\alpha \left[\frac{q\ell}{r^2} \right] \times 10^9 \text{ V}$, where the value of α is _____ . (Use $\frac{1}{4\pi\epsilon_0} = 9 \times 10^9 \text{ Nm}^2\text{C}^{-2}$)

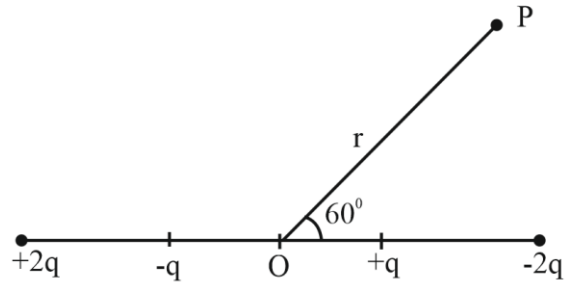

Ans. (27)

Sol.

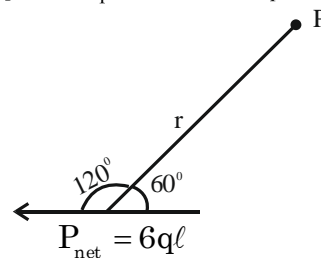
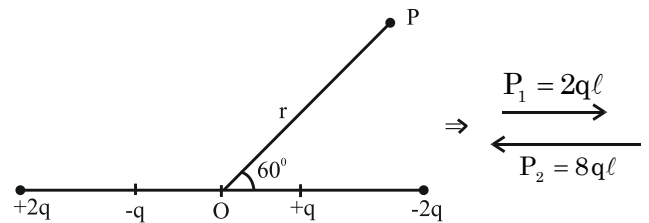

$$V = \frac{K \vec{p} \cdot \vec{r}}{r^3} = \frac{9 \times 10^9 (6q\ell)}{r^2} \cos(120^\circ)$$

$$= -(27) \left(\frac{q\ell}{r^2} \right) \times 10^9 \text{ Nm}^2\text{c}^{-2}$$

$$\Rightarrow \alpha = 27$$

58. Two identical spheres each of mass 2 kg and radius 50 cm are fixed at the ends of a light rod so that the separation between the centers is 150 cm. Then, moment of inertia of the system about an axis perpendicular to the rod and passing through its middle point is $\frac{x}{20} \text{ kg m}^2$, where the value of x is _____.

Ans. (53)

Sol.

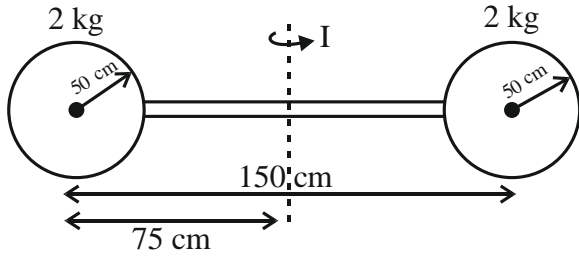

$$I = \left(\frac{2}{5} mR^2 + md^2 \right) \times 2$$

$$I = 2 \left(\frac{2}{5} \times 2 \times \left(\frac{1}{2} \right)^2 + 2 \times \left(\frac{3}{4} \right)^2 \right) = \frac{53}{20} \text{ kg} \cdot \text{m}^2$$

$$X = 53$$

59. The time period of simple harmonic motion of mass M in the given figure is $\pi \sqrt{\frac{\alpha M}{5K}}$, where the value of α is _____.

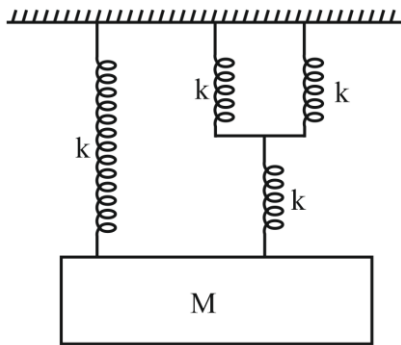

Ans. (12)

Sol. $k_{\text{eq}} = \frac{2k \cdot k}{3k} + k = \frac{5k}{3}$

Angular frequency of oscillation $(\omega) = \sqrt{\frac{k_{\text{eq}}}{m}}$

$$(\omega) = \sqrt{\frac{5k}{3m}}$$

Period of oscillation $(\tau) = \frac{2\pi}{\omega} = 2\pi \sqrt{\frac{3m}{5k}}$

$$= \pi \sqrt{\frac{12m}{5k}}$$

60. A nucleus has mass number A_1 and volume V_1 . Another nucleus has mass number A_2 and volume V_2 . If relation between mass number is $A_2 = 4A_1$, then $\frac{V_2}{V_1} = \underline{\hspace{2cm}}$.

Ans. (4)

Sol. For a nucleus

Volume: $V = \frac{4}{3} \pi R^3$

$$R = R_0 (A)^{1/3}$$

$$V = \frac{4}{3} \pi R_0^3 A$$

$$\Rightarrow \frac{V_2}{V_1} = \frac{A_2}{A_1} = 4$$

CHEMISTRY

TEST PAPER WITH SOLUTION

SECTION-A

61. Match List I with List II

LIST – I (Complex ion)		LIST – II (Electronic Configuration)	
A.	$[\text{Cr}(\text{H}_2\text{O})_6]^{3+}$	I.	$t_{2g}^2 e_g^0$
B.	$[\text{Fe}(\text{H}_2\text{O})_6]^{3+}$	II.	$t_{2g}^3 e_g^0$
C.	$[\text{Ni}(\text{H}_2\text{O})_6]^{2+}$	III.	$t_{2g}^3 e_g^2$
D.	$[\text{V}(\text{H}_2\text{O})_6]^{3+}$	IV.	$t_{2g}^6 e_g^2$

Choose the correct answer from the options given below :

- (1) A-III, B-II, C-IV, D-I
- (2) A-IV, B-I, C-II, D-III
- (3) A-IV, B-III, C-I, D-II
- (4) A-II, B-III, C-IV, D-I

Ans. (4)

Sol:- $[\text{Cr}(\text{H}_2\text{O})_6]^{3+}$ Contains $\text{Cr}^{3+} : [\text{Ar}]3d^3 : t_{2g}^3 e_g^0$

$[\text{Fe}(\text{H}_2\text{O})_6]^{3+}$ Contains $\text{Fe}^{3+} : [\text{Ar}]3d^5 : t_{2g}^3 e_g^2$

$[\text{Ni}(\text{H}_2\text{O})_6]^{2+}$ Contains $\text{Ni}^{2+} : [\text{Ar}]3d^8 : t_{2g}^6 e_g^2$

$[\text{V}(\text{H}_2\text{O})_6]^{3+}$ Contains $\text{V}^{3+} : [\text{Ar}]3d^2 : t_{2g}^2 e_g^0$

62. A sample of CaCO_3 and MgCO_3 weighed 2.21 g is ignited to constant weight of 1.152 g. The composition of mixture is :

(Given molar mass in g mol^{-1}

$\text{CaCO}_3 : 100, \text{MgCO}_3 : 84$)

- (1) 1.187 g CaCO_3 + 1.023 g MgCO_3
- (2) 1.023 g CaCO_3 + 1.023 g MgCO_3
- (3) 1.187 g CaCO_3 + 1.187 g MgCO_3
- (4) 1.023 g CaCO_3 + 1.187 g MgCO_3

Ans. (1)

Sol:- $\text{CaCO}_3(\text{s}) \xrightarrow{\Delta} \text{CaO}(\text{s}) + \text{CO}_2(\text{g})$
 $\text{MgCO}_3(\text{s}) \xrightarrow{\Delta} \text{MgO}(\text{s}) + \text{CO}_2(\text{g})$

Let the weight of CaCO_3 be x gm

\therefore weight of $\text{MgCO}_3 = (2.21 - x)$ gm

Moles of CaCO_3 decomposed = moles of CaO formed

$$\frac{x}{100} = \text{moles of CaO formed}$$

$$\therefore \text{weight of CaO formed} = \frac{x}{100} \times 56$$

Moles of MgCO_3 decomposed = moles of MgO formed

$$\frac{(2.21 - x)}{84} = \text{moles of MgO formed}$$

$$\therefore \text{weight of MgO formed} = \frac{2.21 - x}{84} \times 40$$

$$\Rightarrow \frac{2.21 - x}{84} \times 40 + \frac{x}{100} \times 56 = 1.152$$

$$\therefore x = 1.1886 \text{ g} = \text{weight of } \text{CaCO}_3$$

& weight of $\text{MgCO}_3 = 1.0214 \text{ g}$

63. Identify A and B in the following reaction sequence.

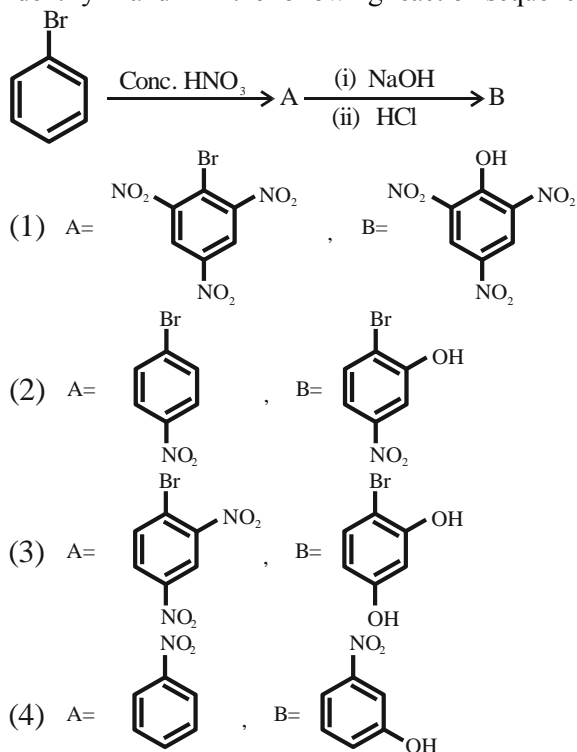

Ans. (1)

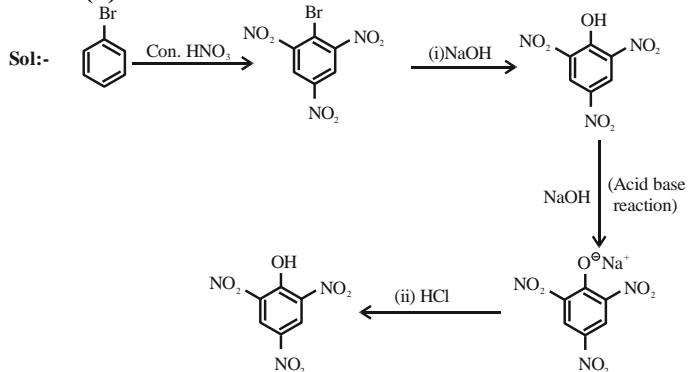

64. Given below are two statements :

Statement I: S_8 solid undergoes disproportionation reaction under alkaline conditions to form S^{2-} and $S_2O_3^{2-}$

Statement II: ClO_4^- can undergo disproportionation reaction under acidic condition. In the light of the above statements, choose the **most appropriate answer** from the options given below :

- (1) Statement I is correct but statement II is incorrect.
- (2) Statement I is incorrect but statement II is correct
- (3) Both statement I and statement II are incorrect
- (4) Both statement I and statement II are correct

Ans. (1)

Sol:-

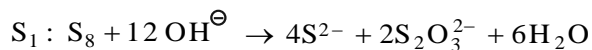

$S_2 : ClO_4^\ominus$ cannot undergo disproportionation reaction as chlorine is present in its highest oxidation state.

65. Identify major product 'P' formed in the following reaction.

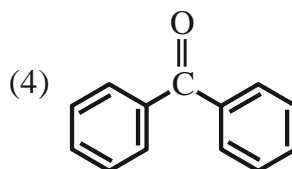
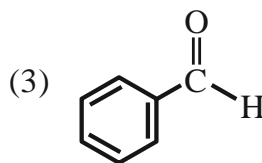
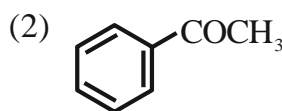
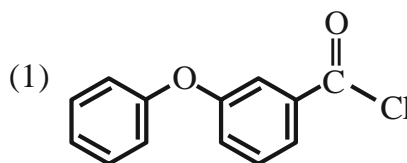
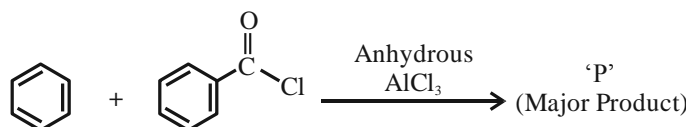

Ans. (4)

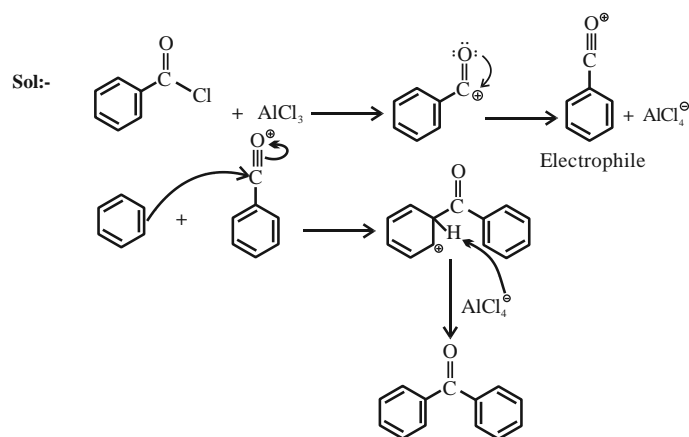

66. Major product of the following reaction is –

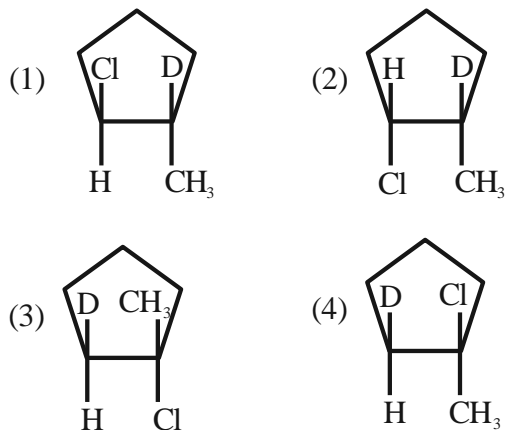
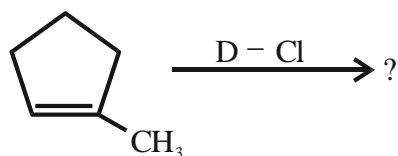

Ans. (3 or 4)

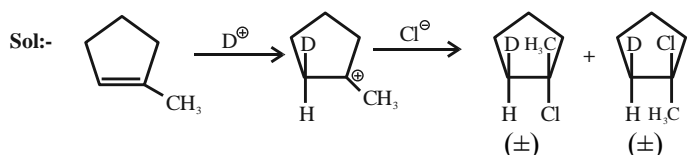

67. Identify structure of 2,3-dibromo-1-phenylpentane.

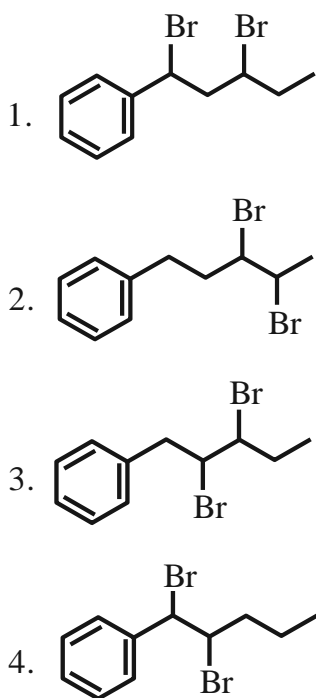

Ans. (3)

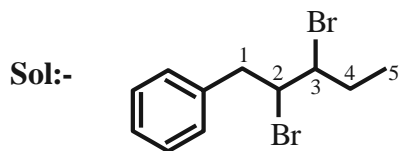

2, 3-dibromo -1-phenylpentane

68. Select the option with correct property -

- (1) $[\text{Ni}(\text{CO})_4]$ and $[\text{NiCl}_4]^{2-}$ both diamagnetic
- (2) $[\text{Ni}(\text{CO})_4]$ and $[\text{NiCl}_4]^{2-}$ both paramagnetic
- (3) $[\text{NiCl}_4]^{2-}$ diamagnetic, $[\text{Ni}(\text{CO})_4]$ paramagnetic
- (4) $[\text{Ni}(\text{CO})_4]$ diamagnetic, $[\text{NiCl}_4]^{2-}$ paramagnetic

Ans. (4)

Sol:- $[\text{Ni}(\text{CO})_4] \rightarrow$ diamagnetic, sp^3 hybridisation, number of unpaired electrons = 0

$[\text{NiCl}_4]^{2-}, \rightarrow$ paramagnetic, sp^3 hybridisation, number of unpaired electrons = 2

69. The azo-dye (Y) formed in the following reactions is Sulphanilic acid + NaNO_2 + $\text{CH}_3\text{COOH} \rightarrow \text{X}$

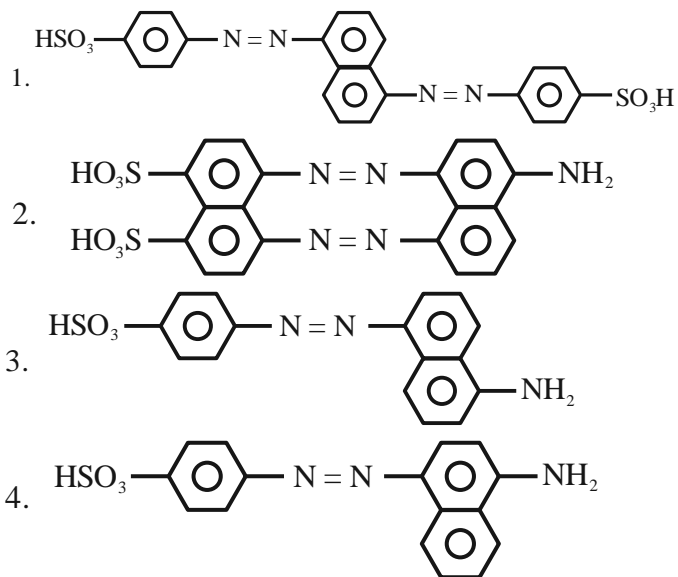
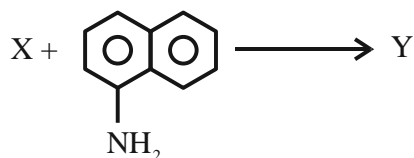

Ans. (4)

Sol:-

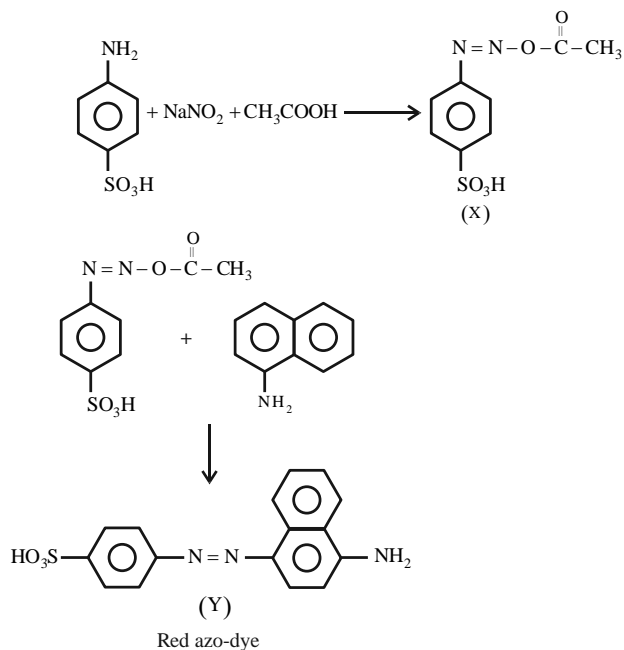

This is known as Griess-Ilosvay test.

70. Given below are two statements :

Statement I: Aniline reacts with con. H_2SO_4 followed by heating at 453-473 K gives p-aminobenzene sulphonic acid, which gives blood red colour in the 'Lassaigne's test'.

Statement II: In Friedel - Craft's alkylation and acylation reactions, aniline forms salt with the AlCl_3 catalyst. Due to this, nitrogen of aniline acquires a positive charge and acts as deactivating group.

In the light of the above statements, choose the **correct answer** from the options given below :

1. Statement I is false but statement II is true
2. Both statement I and statement II are false
3. Statement I is true but statement II is false
4. Both statement I and statement II are true

Ans. (4)

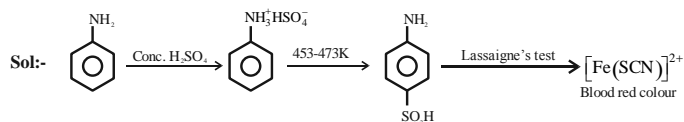

71. $\text{A}_{(\text{g})} \rightleftharpoons \text{B}_{(\text{g})} + \frac{\text{C}}{2}_{(\text{g})}$ The correct relationship between K_p , α and equilibrium pressure P is

- (1) $K_p = \frac{\alpha^{1/2} P^{1/2}}{(2 + \alpha)^{1/2}}$
- (2) $K_p = \frac{\alpha^{3/2} P^{1/2}}{(2 + \alpha)^{1/2} (1 - \alpha)}$
- (3) $K_p = \frac{\alpha^{1/2} P^{3/2}}{(2 + \alpha)^{3/2}}$
- (4) $K_p = \frac{\alpha^{1/2} P^{1/2}}{(2 + \alpha)^{3/2}}$

Ans. (2)

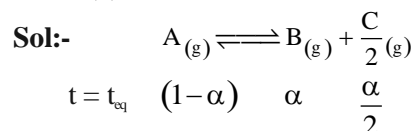

$$P_B = \frac{\alpha}{\left(1 + \frac{\alpha}{2}\right)} \cdot P, \quad P_A = \frac{(1 - \alpha)}{\left(1 + \frac{\alpha}{2}\right)} \cdot P, \quad P_C = \frac{\frac{\alpha}{2}}{\left(1 + \frac{\alpha}{2}\right)} \cdot P$$

$$K_p = \frac{P_B \cdot P_C^{1/2}}{P_A}$$

$$= \frac{(\alpha)^{3/2} (P)^{1/2}}{(1 - \alpha)(2 + \alpha)^{1/2}}$$

72. Choose the correct statements from the following

- A. All group 16 elements form oxides of general formula EO_2 and EO_3 where E = S, Se, Te and Po. Both the types of oxides are acidic in nature.
- B. TeO_2 is an oxidising agent while SO_2 is reducing in nature.
- C. The reducing property decreases from H_2S to H_2Te down the group.
- D. The ozone molecule contains five lone pairs of electrons.

Choose the correct answer from the options given below:

1. A and D only
2. B and C only
3. C and D only
4. A and B only

Ans. (4)

Sol:- (A) All group 16 elements form oxides of the EO_2 and EO_3 type where $E = S, Se, Te$ or Po .

(B) SO_2 is reducing while TeO_2 is an oxidising agent.

(C) The reducing property increases from H_2S to H_2Te down the group.

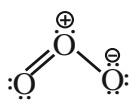
(D)  have six lone pairs

73. Identify the name reaction.

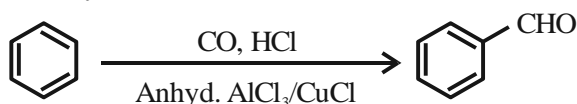

- (1) Stephen reaction
- (2) Etard reaction
- (3) Gatterman-koch reaction
- (4) Rosenmund reduction

Ans. (3)

Sol:-

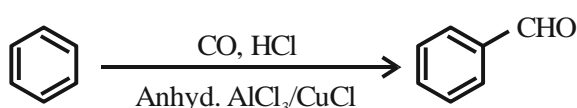

Gatterman-Koch reaction

74. Which of the following is least ionic ?

- (1) $BaCl_2$
- (2) $AgCl$
- (3) KCl
- (4) $CoCl_2$

Ans. (2)

Sol:- $AgCl < CoCl_2 < BaCl_2 < KCl$ (ionic character)

Reason : Ag^+ has pseudo inert gas configuration.

75. The fragrance of flowers is due to the presence of some steam volatile organic compounds called essential oils. These are generally insoluble in water at room temperature but are miscible with water vapour in vapour phase. A suitable method for the extraction of these oils from the flowers is -

1. crystallisation
2. distillation under reduced pressure
3. distillation
4. steam distillation

Ans. (4)

Sol:- Steam distillation technique is applied to separate substances which are steam volatile and are immiscible with water.

76. Given below are two statements :

Statement I: Group 13 trivalent halides get easily hydrolyzed by water due to their covalent nature.

Statement II: $AlCl_3$ upon hydrolysis in acidified aqueous solution forms octahedral $[Al(H_2O)_6]^{3+}$ ion.

In the light of the above statements, choose the **correct answer** from the options given below :

1. Statement I is true but statement II is false
2. Statement I is false but statement II is true
3. Both statement I and statement II are false
4. Both statement I and statement II are true

Ans. (4)

Sol:- In trivalent state most of the compounds being covalent are hydrolysed in water. Trichlorides on hydrolysis in water form tetrahedral $[M(OH)_4]^-$ species, the hybridisation state of element M is sp^3 .

In case of aluminium, acidified aqueous solution forms octahedral $[Al(H_2O)_6]^{3+}$ ion.

77. The four quantum numbers for the electron in the outer most orbital of potassium (atomic no. 19) are

- (1) $n = 4, l = 2, m = -1, s = +\frac{1}{2}$
- (2) $n = 4, l = 0, m = 0, s = +\frac{1}{2}$
- (3) $n = 3, l = 0, m = 1, s = +\frac{1}{2}$
- (4) $n = 2, l = 0, m = 0, s = +\frac{1}{2}$

Ans. (2)

Sol:- ${}_{19}K \quad 1s^2, 2s^2, 2p^6, 3s^2, 3p^6, 4s^1$.

Outermost orbital of potassium is 4s orbital

$n = 4, l = 0, m_1 = 0, s = \pm \frac{1}{2}$.

78. Choose the correct statements from the following

- A. Mn_2O_7 is an oil at room temperature
- B. V_2O_4 reacts with acid to give VO_2^{2+}
- C. CrO is a basic oxide
- D. V_2O_5 does not react with acid

Choose the correct answer from the options given below :

- 1. A, B and D only
- 2. A and C only
- 3. A, B and C only
- 4. B and C only

Ans. (2)

Sol:- (A) Mn_2O_7 is green oil at room temperature.

(B) V_2O_4 dissolve in acids to give VO^{2+} salts.

(C) CrO is basic oxide

(D) V_2O_5 is amphoteric it reacts with acid as well as base.

79. The correct order of reactivity in electrophilic substitution reaction of the following compounds

is :

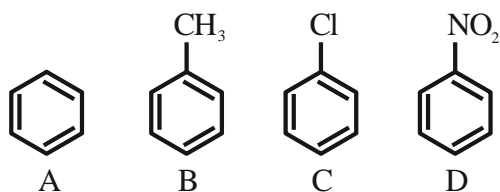

- 1. $B > C > A > D$
- 2. $D > C > B > A$
- 3. $A > B > C > D$
- 4. $B > A > C > D$

Ans. (4)

Sol:- $-CH_3$ shows +M and +I.

$-Cl$ shows +M and $-I$ but inductive effect dominates.

$-NO_2$ shows $-M$ and $-I$.

Electrophilic substitution $\propto \frac{1}{-M \text{ and } -I}$

$\propto +M \text{ and } +I$

Hence, order is $B > A > C > D$.

80. Consider the following elements.

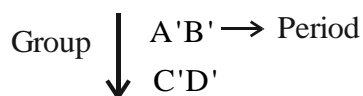

Which of the following is/are true about A', B', C' and D' ?

- A. Order of atomic radii: $B' < A' < D' < C'$
- B. Order of metallic character : $B' < A' < D' < C'$
- C. Size of the element : $D' < C' < B' < A'$
- D. Order of ionic radii : $B^{++} < A^{++} < D^{++} < C^{++}$

Choose the correct answer from the options given below :

- 1. A only
- 2. A, B and D only
- 3. A and B only
- 4. B, C and D only

Ans. (2)

Sol:- In general along the period from left to right, size decreases and metallic character decrease.

In general down the group, size increases and metallic character increases.

$B' < A'$ (size) $C' > A'$ (size)

$D' < C'$ (size) $D' > B'$ (size)

$B' < A'$ (metallic character)

$D' < C'$ (metallic character)

$B^{++} < A^{++}$ (size)

$D^{++} < C^{++}$ (size)

\therefore C statement is incorrect.

SECTION-B

- 81.** A diatomic molecule has a dipole moment of 1.2 D. If the bond distance is 1 \AA , then fractional charge on each atom is $\times 10^{-1}$ esu.

(Given $1\text{ D} = 10^{-18}$ esu cm)

Ans. (0)

Sol:- $\mu = 1.2\text{ D} = q \times d$

$$\Rightarrow 1.2 \times 10^{-10} \text{ esu } \text{\AA} = q \times 1\text{\AA}$$

$$\therefore q = 1.2 \times 10^{-10} \text{ esu}$$

- 82.** $r = k[A]$ for a reaction, 50% of A is decomposed in 120 minutes. The time taken for 90% decomposition of A is _____ minutes.

Ans. (399)

Sol:- $r = k[A]$

So, order of reaction = 1

$$t_{1/2} = 120 \text{ min}$$

For 90% completion of reaction

$$\Rightarrow k = \frac{2.303}{t} \log \left(\frac{a}{a-x} \right)$$

$$\Rightarrow \frac{0.693}{t_{1/2}} = \frac{2.303}{t} \log \frac{100}{10}$$

$$\therefore t = 399 \text{ min.}$$

- 83.** A compound (x) with molar mass 108 g mol^{-1} undergoes acetylation to give product with molar mass 192 g mol^{-1} . The number of amino groups in the compound (x) is _____.

Ans. (2)

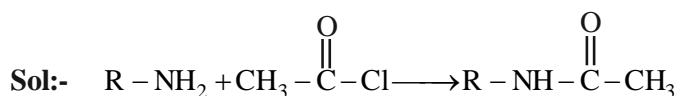

Gain in molecular weight after acylation with one $-\text{NH}_2$ group is 42.

Total increase in molecular weight = 84

$$\therefore \text{Number of amino group in } x = \frac{84}{42} = 2$$

- 84.** Number of isomeric products formed by mono-chlorination of 2-methylbutane in presence of sunlight is _____.

Ans. (6)

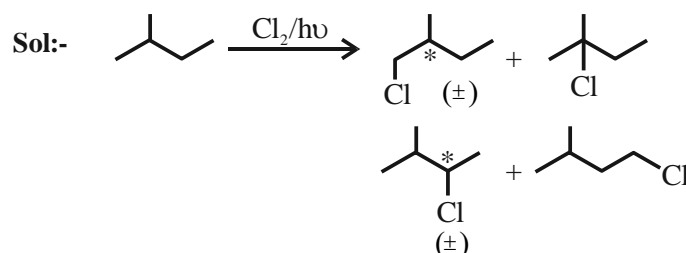

\therefore Number of isomeric products = 6

- 85.** Number of moles of H^+ ions required by 1 mole of MnO_4^- to oxidise oxalate ion to CO_2 is _____.

Ans. (8)

Sol:-

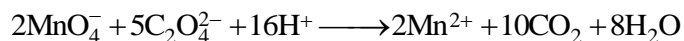

\therefore Number of moles of H^+ ions required by 1 mole of MnO_4^- to oxidise oxalate ion to CO_2 is 8

- 86.** In the reaction of potassium dichromate, potassium chloride and sulfuric acid (conc.), the oxidation state of the chromium in the product is (+)_____.

Ans. (6)

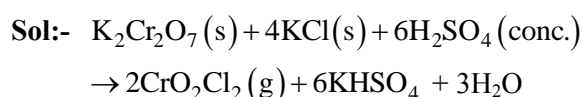

This reaction is called chromyl chloride test.

Here oxidation state of Cr is +6.

- 87.** The molarity of 1L orthophosphoric acid (H_3PO_4) having 70% purity by weight (specific gravity 1.54 g cm^{-3}) is _____ M.

(Molar mass of $\text{H}_3\text{PO}_4 = 98 \text{ g mol}^{-1}$)

Ans. (11)

Sol:- Specific gravity (density) = 1.54 g/cc.
 Volume = 1L = 1000 ml
 Mass of solution = 1.54×1000
 = 1540 g
 % purity of H_2SO_4 is 70%
 So weight of $\text{H}_3\text{PO}_4 = 0.7 \times 1540 = 1078$ g
 Mole of $\text{H}_3\text{PO}_4 = \frac{1078}{98} = 11$
 Molarity = $\frac{11}{1\text{L}} = 11$

88. The values of conductivity of some materials at 298.15 K in S m^{-1} are 2.1×10^3 , 1.0×10^{-16} , 1.2×10^3 , 3.91, 1.5×10^{-2} , 1×10^{-7} , 1.0×10^3 . The number of conductors among the materials is _____.

Ans. (4)

Sol:-

Conductivity (S m^{-1})

$\left. \begin{array}{l} 2.1 \times 10^3 \\ 1.2 \times 10^3 \\ 3.91 \\ 1 \times 10^3 \end{array} \right\}$ conductors at 298.15 K

1×10^{-16} Insulator at 298.15 K

$\left. \begin{array}{l} 1.5 \times 10^{-2} \\ 1 \times 10^{-7} \end{array} \right\}$ Semiconductor at 298.15 K

Therefore number of conductors is 4.

89. From the vitamins A, B_1 , B_6 , B_{12} , C, D, E and K, the number vitamins that can be stored in our body is _____.

Ans. (5)

Sol:- Vitamins A, D, E, K and B_{12} are stored in liver and adipose tissue.

90. If 5 moles of an ideal gas expands from 10 L to a volume of 100 L at 300 K under isothermal and reversible condition then work, w, is $-x$ J. The value of x is _____.

(Given $R = 8.314 \text{ J K}^{-1} \text{ mol}^{-1}$)

Ans. (28721)

Sol:- It is isothermal reversible expansion, so work done negative

$$W = -2.303 nRT \log \left(\frac{V_2}{V_1} \right)$$

$$= -2.303 \times 5 \times 8.314 \times 300 \log \left(\frac{100}{10} \right)$$

$$= -28720.713 \text{ J}$$

$$\equiv -28721 \text{ J}$$