

NEET (National)

Held on : 5 May 2019

SOLVED PAPER 2019

PHYSICS

- For a p -type semiconductor, which of the following statements is true ?
 - Holes are the majority carriers and trivalent atoms are the dopants.
 - Holes are the majority carriers and pentavalent atoms are the dopants.
 - Electrons are the majority carriers and pentavalent atoms are the dopants.
 - Electrons are the majority carriers and trivalent atoms are the dopants.
- A body weighs 200 N on the surface of the earth. How much will it weigh half way down to the centre of the earth ?
 - 200 N
 - 250 N
 - 100 N
 - 150 N
- In which of the following processes, heat is neither absorbed nor released by a system?
 - Adiabatic
 - Isobaric
 - Isochoric
 - Isothermal
- Six similar bulbs are connected as shown in the figure with a DC source of emf E and zero internal resistance. The ratio of power consumption by the bulbs when (i) all are glowing and (ii) in the situation when two from section A and one from section B are glowing, will be
- A small hole of area of cross-section 2 mm^2 is present near the bottom of a fully filled open tank of height 2 m. Taking $g = 10 \text{ m/s}^2$, the rate of flow of water through the open hole would be nearly
 - $8.9 \times 10^{-6} \text{ m}^3/\text{s}$
 - $2.23 \times 10^{-6} \text{ m}^3/\text{s}$
 - $6.4 \times 10^{-6} \text{ m}^3/\text{s}$
 - $12.6 \times 10^{-6} \text{ m}^3/\text{s}$
- A force $F = 20 + 10y$ acts on a particle in y -direction, where F is in newton and y in meter. Work done by this force to move the particle from $y = 0$ to $y = 1 \text{ m}$ is
 - 5 J
 - 25 J
 - 20 J
 - 30 J
- Two point charges A and B , having charges $+Q$ and $-Q$ respectively, are placed at certain distance apart and force acting between them is F . If 25% charge of A is transferred to B , then force between the charges becomes
 - $\frac{9F}{16}$
 - $\frac{16F}{9}$
 - $\frac{4F}{3}$
 - F

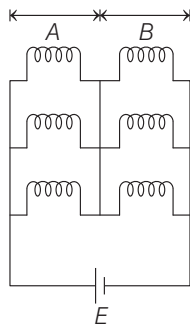

- (a) 9 : 4 (b) 1 : 2 (c) 2 : 1 (d) 4 : 9

- When an object is shot from the bottom of a long smooth inclined plane kept at an angle 60° with horizontal, it can travel a distance x_1 along the plane. But when the inclination is decreased to 30° and the same object is shot with the same velocity, it can travel x_2 distance.

Then $x_1 : x_2$ will be

- $\sqrt{2}:1$
- $1:\sqrt{3}$
- $1:2\sqrt{3}$
- $1:\sqrt{2}$

2 NEET (National) Solved Paper 2019

- 9.** Pick the wrong answer in the context with rainbow.
- The order of colours is reversed in the secondary rainbow
 - An observer can see a rainbow when his front is towards the sun
 - Rainbow is a combined effect of dispersion refraction and reflection of sunlight
 - When the light rays undergo two internal reflections in a water drop, a secondary rainbow is formed

- 10.** Average velocity of a particle executing SHM in one complete vibration is

- (a) $A\omega$ (b) $\frac{A\omega^2}{2}$ (c) zero (d) $\frac{A\omega}{2}$

- 11.** The total energy of an electron in an atom in an orbit is -3.4 eV.

Its kinetic and potential energies are, respectively:

- (a) -3.4 eV, -6.8 eV (b) 3.4 eV, -6.8 eV
(c) 3.4 eV, 3.4 eV (d) -3.4 eV, -3.4 eV

- 12.** At a point A on the earth's surface the angle of dip, $\delta = +25^\circ$.

At a point B on the earth's surface the angle of dip, $\delta = -25^\circ$.

We can interpret that

- A is located in the southern hemisphere and B is located in the northern hemisphere.
- A is located in the northern hemisphere and B is located in the southern hemisphere.
- A and B are both located in the southern hemisphere.
- A and B are both located in the northern hemisphere.

- 13.** In which of the following devices, the eddy current effect is not used?

- Magnetic braking in train
- Electromagnet
- Electric heater
- Induction furnace

- 14.** Two particles A and B are moving in uniform circular motion in concentric circles of radii r_A and r_B with speed v_A and v_B respectively. Their time period of rotation is the same. The ratio of angular speed of A to that of B will be

- (a) $v_A : v_B$ (b) $r_B : r_A$
(c) 1 : 1 (d) $r_A : r_B$

- 15.** Two similar thin equi-convex lenses, of focal length f each, are kept co-axially in contact with each other such that the focal length of the combination is F_1 .

When the space between the two lenses is filled with glycerine (which has the same refractive index ($\mu = 1.5$) as that of glass) then the equivalent focal length is F_2 .

The ratio $F_1 : F_2$ will be

- (a) 1 : 2 (b) 2 : 3 (c) 3 : 4 (d) 2 : 1

- 16.** An electron is accelerated through a potential difference of 10,000 V.

Its de-Broglie wavelength is, (nearly) :

($m_e = 9 \times 10^{-31}$ kg)

- (a) 122×10^{-12} m (b) 122×10^{-14} m
(c) 122 nm (d) 122×10^{-13} m

- 17.**

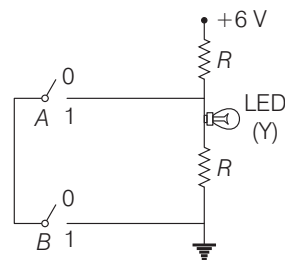

The correct Boolean operation represented by the circuit diagram drawn is

- (a) OR (b) NAND (c) NOR (d) AND

- 18.** A soap bubble, having radius of 1 mm, is blown from a detergent solution having a surface tension of 2.5×10^{-2} N/m.

The pressure inside the bubble equals at a point Z_0 below the free surface of water in a container.

Taking $g = 10$ m/s², density of water = 10^3 kg/m³, the value of Z_0 is

- (a) 10 cm (b) 1 cm
(c) 0.5 cm (d) 100 cm

- 19.** The displacement of a particle executing simple harmonic motion is given by $y = A_0 + A \sin \omega t + B \cos \omega t$

Then the amplitude of its oscillation is given by

- (a) $\sqrt{A^2 + B^2}$ (b) $\sqrt{A_0^2 + (A + B)^2}$
(c) $A + B$ (d) $A_0 + \sqrt{A^2 + B^2}$

20. The work done to raise a mass m from the surface of the earth to a height h , which is equal to the radius of the earth, is

- (a) $2mgR$ (b) $\frac{1}{2}mgR$ (c) $\frac{3}{2}mgR$ (d) mgR

21. The speed of a swimmer in still water is 20 m/s. The speed of river water is 10 m/s and is flowing due east. If he is standing on the south bank and wishes to cross the river along the shortest path the angle at which he should make his strokes w.r.t. north is given by

- (a) 0° (b) 60° west
(c) 45° west (d) 30° west

22. Two parallel infinite line charges with linear charge densities $+\lambda$ C/m and $-\lambda$ C/m are placed at a distance of $2R$ in free space. What is the electric field mid-way between the two line charges?

- (a) $\frac{2\lambda}{\pi\epsilon_0 R}$ N/C (b) $\frac{\lambda}{\pi\epsilon_0 R}$ N/C
(c) $\frac{\lambda}{2\pi\epsilon_0 R}$ N/C (d) Zero

23. Which of the following acts as a circuit protection device?

- (a) Inductor (b) Switch
(c) Fuse (d) Conductor

24. A parallel plate capacitor of capacitance $20\mu\text{F}$ is being charged by a voltage source whose potential is changing at the rate of 3 V/s. The conduction current through the connecting wires and the displacement current through the plates of the capacitor, would be, respectively.

- (a) $60\mu\text{A}$, $60\mu\text{A}$ (b) $60\mu\text{A}$, zero
(c) zero, zero (d) zero, $60\mu\text{A}$

25. When a block of mass M is suspended by a long wire of length L , the length of the wire becomes $(L + l)$.

The elastic potential energy stored in the extended wire is

- (a) MgL (b) $\frac{1}{2}Mgl$
(c) $\frac{1}{2}MgL$ (d) Mgl

26. A hollow metal sphere of radius R is uniformly charged.

The electric field due to the sphere at a distance r from the centre

- (a) zero as r increases for $r < R$, decreases as r increases for $r > R$
(b) zero as r increases for $r < R$, increases as r increases for $r > R$
(c) decreases as r increases for $r < R$ and for $r > R$
(d) increases as r increases for $r < R$ and for $r > R$

27. A mass m is attached to a thin wire and whirled in a vertical circle.

The wire is most likely to break when:

- (a) the wire is horizontal
(b) the mass is at the lowest point
(c) inclined at an angle of 60° from vertical
(d) the mass is at the highest point

28. Which colour of the light has the longest wavelength?

- (a) Blue (b) Green
(c) Violet (d) Red

29. A particle moving with velocity v is acted by three forces shown by the vector triangle PQR.

The velocity of the particle will

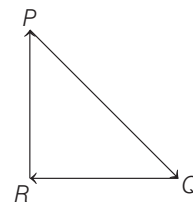

- (a) decrease
(b) remain constant
(c) change according to the smallest force QR
(d) increase

30. Ionised hydrogen atoms and α -particles with same momenta enters perpendicular to a constant magnetic field, B .

The ratio of their radii of their paths $r_H : r_\alpha$ will be

- (a) 1 : 2 (b) 4 : 1
(c) 1 : 4 (d) 2 : 1

31. The unit of thermal conductivity is :

- (a) $\text{J m}^{-1} \text{K}^{-1}$ (b) W m K^{-1}
(c) $\text{W m}^{-1} \text{K}^{-1}$ (d) J m K^{-1}

4 NEET (National) Solved Paper 2019

- 32.** A coil of 800 turns effective area 0.05 m^2 is kept perpendicular to a magnetic field $5 \times 10^{-5} \text{ T}$. When the plane of the coil is rotated by 90° around any of its co-planar axis in 0.1 s , the emf induced in the coil will be

(a) 0.2 V (b) $2 \times 10^{-3} \text{ V}$
(c) 0.02 V (d) 2 V

- 33.** A disc of radius 2 m and mass 100 kg rolls on a horizontal floor. Its centre of mass has speed of 20 cm/s . How much work is needed to stop it?

(a) 30 kJ (b) 2 J
(c) 1 J (d) 3 J

- 34.** In an experiment, the percentage of error occurred in the measurement of physical quantities A, B, C and D are 1%, 2%, 3% and 4% respectively. Then the maximum percentage of error in the measurement X, where, $X = \frac{A^2 B^{1/2}}{C^{1/3} D^3}$ will be

(a) 16% (b) -10% (c) 10% (d) $\left(\frac{3}{13}\right)\%$

- 35.** Body A of mass $4m$ moving with speed u collides with another body B of mass $2m$, at rest. The collision is head on and elastic in nature. After the collision the fraction of energy lost by the colliding body A is

(a) $\frac{8}{9}$ (b) $\frac{4}{9}$ (c) $\frac{5}{9}$ (d) $\frac{1}{9}$

- 36.** The radius of circle, the period of revolution, initial position and sense of revolution are indicated in the below fig.

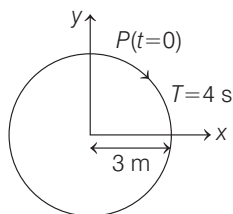

y-projection of the radius vector of rotating particle P is

(a) $y(t) = 4 \sin\left(\frac{\pi t}{2}\right)$, where y in m
(b) $y(t) = 3 \cos\left(\frac{3\pi t}{2}\right)$, where y in m

(c) $y(t) = 3 \cos\left(\frac{\pi t}{2}\right)$, where y in m

(d) $y(t) = -3 \cos 2\pi t$, where y in m

- 37.** In total internal reflection when the angle of incidence is equal to the critical angle for the pair of media in contact, what will be angle of refraction?

(a) 0°
(b) Equal to angle of incidence
(c) 90°
(d) 180°

- 38.** A solid cylinder of mass 2 kg and radius 4 cm is rotating about its axis at the rate of 3 rpm . The torque required to stop after 2π revolutions is

(a) $2 \times 10^{-3} \text{ N-m}$ (b) $12 \times 10^{-4} \text{ N-m}$
(c) $2 \times 10^6 \text{ N-m}$ (d) $2 \times 10^{-6} \text{ N-m}$

- 39.** A block of mass 10 kg is in contact against the inner wall of a hollow cylindrical drum of radius 1 m . The coefficient of friction between the block and the inner wall of the cylinder is 0.1 . The minimum angular velocity needed for the cylinder to keep the block stationary when the cylinder is vertical and rotating about its axis, will be ($g = 10 \text{ m/s}^2$)

(a) $\frac{10}{2\pi} \text{ rad/s}$ (b) 10 rad/s
(c) $10\pi \text{ rad/s}$ (d) $\sqrt{10} \text{ rad/s}$

- 40.** A cylindrical conductor of radius R is carrying a constant current. The plot of the magnitude of the magnetic field B with the distance d from the centre of the conductor, is correctly represented by the figure

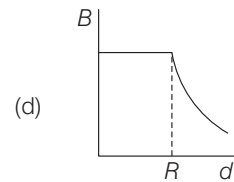
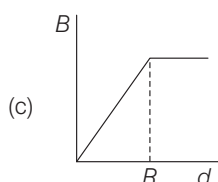
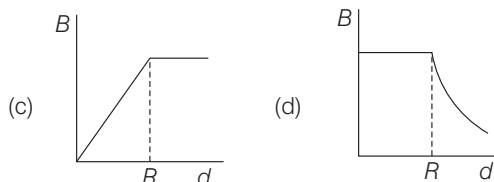
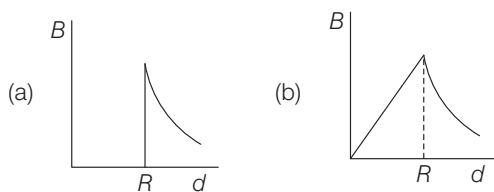

41. In the circuits shown below, the readings of voltmeters and the ammeters will be

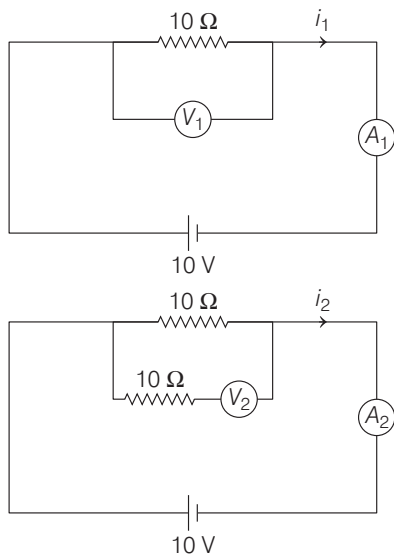

- (a) $V_1 = V_2$ and $i_1 > i_2$
 (b) $V_1 = V_2$ and $i_1 = i_2$
 (c) $V_2 > V_1$ and $i_1 > i_2$
 (d) $V_2 > V_1$ and $i_1 = i_2$

CHEMISTRY

46. For the chemical reaction,

$$\text{N}_2(\text{g}) + 3\text{H}_2(\text{g}) \rightleftharpoons 2\text{NH}_3(\text{g})$$

The correct option is

- (a) $-\frac{d[\text{N}_2]}{dt} = 2 \frac{d[\text{NH}_3]}{dt}$
 (b) $-\frac{d[\text{N}_2]}{dt} = \frac{1}{2} \frac{d[\text{NH}_3]}{dt}$
 (c) $3 \frac{d[\text{H}_2]}{dt} = 2 \frac{d[\text{NH}_3]}{dt}$
 (d) $-\frac{1}{3} \frac{d[\text{H}_2]}{dt} = -\frac{1}{2} \frac{d[\text{NH}_3]}{dt}$

47. The non-essential amino acid among the following is
 (a) leucine (b) alanine (c) lysine (d) valine
48. For an ideal solution, the correct option is
 (a) $\Delta_{\text{mix}} V \neq 0$ at constant T and p
 (b) $\Delta_{\text{mix}} H = 0$ at constant T and p
 (c) $\Delta_{\text{mix}} G = 0$ at constant T and p
 (d) $\Delta_{\text{mix}} S = 0$ at constant T and p

42. Increase in temperature of a gas filled in a container would lead to
 (a) increase in its kinetic energy
 (b) decrease in its pressure
 (c) decrease in intermolecular distance
 (d) increase in its mass
43. A copper rod of 88 cm and an aluminium rod of unknown length have their increase in length independent of increase in temperature. The length of aluminium rod is
 (a) 113.9 cm (b) 88 cm (c) 68 cm (d) 6.8 cm
44. α -particle consists of
 (a) 2 electrons, 2 protons and 2 neutrons
 (b) 2 electrons and 4 protons only
 (c) 2 protons only
 (d) 2 protons and 2 neutrons only
45. In a double slit experiment, when light of wavelength 400 nm was used, the angular width of the first minima formed on a screen placed 1 m away, was found to be 0.2° . What will be the angular width of the first minima, if the entire experimental apparatus is immersed in water? ($\mu_{\text{water}} = 4/3$)
 (a) 0.15° (b) 0.051° (c) 0.1° (d) 0.266°

49. The manganate and permanganate ions are tetrahedral, due to
 (a) there is no π -bonding
 (b) the π -bonding involves overlap of p -orbitals of oxygen with p -orbitals of manganese
 (c) the π -bonding involves overlap of d -orbitals of oxygen with d -orbitals of manganese
 (d) the π -bonding involves overlap of p -orbitals of oxygen with d -orbitals of manganese
50. Which will make basic buffer?
 (a) 100 mL of 0.1 M CH_3COOH + 100 mL of 0.1 M NaOH
 (b) 100 mL of 0.1 M HCl + 200 mL of 0.1 M NH_4OH
 (c) 100 mL of 0.1 M HCl + 100 mL of 0.1 M NaOH
 (d) 50 mL of 0.1 M NaOH + 25 mL of 0.1 M CH_3COOH
51. The number of moles of hydrogen molecules required to produce 20 moles of ammonia through Haber's process is
 (a) 20 (b) 30 (c) 40 (d) 10

6 NEET (National) Solved Paper 2019

52. Which of the following diatomic molecular species has only π -bonds according to molecular orbital theory?

- (a) N_2 (b) C_2 (c) Be_2 (d) O_2

53. The biodegradable polymer is

- (a) nylon-2-nylon-6 (b) nylon-6
(c) buna-S (d) nylon-6,6

54. Which of the following reactions are disproportionation reaction?

- (i) $2Cu^+ \longrightarrow Cu^{2+} + Cu^0$
(ii) $3MnO_4^{2-} + 4H^+ \longrightarrow 2MnO_4^- + MnO_2 + 2H_2O$
(iii) $2KMnO_4 \xrightarrow{\Delta} K_2MnO_4 + MnO_2 + O_2$
(iv) $2MnO_4^- + 3Mn^{2+} + 2H_2O \longrightarrow 5MnO_2 + 4H^+$

Select the correct option from the following.

- (a) (i), (ii) and (iii) (b) (i), (iii) and (iv)
(c) (i) and (iv) only (d) (i) and (ii) only

55. The compound that is most difficult to protonate is

- (a) H_3C-O-H (b) $H_3C-O-CH_3$
(c) $Ph-O-H$ (d) $H-O-H$

56. Which of the following species is not stable?

- (a) $[GeCl_6]^{2-}$ (b) $[Sn(OH)_6]^{2-}$
(c) $[SiCl_6]^{2-}$ (d) $[SiF_6]^{2-}$

57. An alkene 'A' on reaction with O_3 and $Zn-H_2O$ gives propanone and ethanal in equimolar ratio. Addition of HCl to alkene 'A' gives 'B' as the major product. The structure of product 'B' is

- (a) $H_3C-CH_2-\overset{\overset{CH_2Cl}{|}}{C}-CH_3$
(b) $H_3C-CH_2-\overset{\overset{CH_3}{|}}{C}-CH_3$
(c) $H_3C-\overset{\overset{Cl}{|}}{C}-\overset{\overset{CH_3}{|}}{C}-H$
(d) $Cl-CH_2-CH_2-\overset{\overset{CH_3}{|}}{C}-CH_3$

58. Match the following :

A. Pure nitrogen	(i)	Chlorine
B. Haber process	(ii)	Sulphuric acid
C. Contact process	(iii)	Ammonia
D. Deacon's process	(iv)	Sodium azide or barium azide

Which of the following is the correct option?

- | | A | B | C | D |
|-----|-------|-------|-------|-------|
| (a) | (ii) | (iv) | (i) | (iii) |
| (b) | (iii) | (iv) | (ii) | (i) |
| (c) | (iv) | (iii) | (ii) | (i) |
| (d) | (i) | (ii) | (iii) | (iv) |

59. The most suitable reagent for the following conversion, is

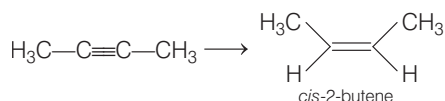

- (a) H_2 , Pd/C, quinoline
(b) Zn/HCl
(c) Hg^{2+}/H^+ , H_2O
(d) Na/liquid NH_3

60. The correct order of the basic strength of methyl substituted amines in aqueous solution is

- (a) $(CH_3)_3N > CH_3NH_2 > (CH_3)_2NH$
(b) $(CH_3)_3N > (CH_3)_2NH > CH_3NH_2$
(c) $CH_3NH_2 > (CH_3)_2NH > (CH_3)_3N$
(d) $(CH_3)_2NH > CH_3NH_2 > (CH_3)_3N$

61. A gas at 350 K and 15 bar has molar volume 20 percent smaller than that for an ideal gas under the same conditions.

The correct option about the gas and its compressibility factor (Z) is

- (a) $Z > 1$ and repulsive forces are dominant
(b) $Z < 1$ and attractive forces are dominant
(c) $Z < 1$ and repulsive forces are dominant
(d) $Z > 1$ and attractive forces are dominant

62. The number of sigma (σ) and pi (π) bonds in pent-2-en-4-yne is

- (a) 8 σ -bonds and 5 π -bonds
(b) 11 σ -bonds and 2 π -bonds
(c) 13 σ -bonds and no π -bonds
(d) 10 σ -bonds and 3 π -bonds

63. For the second period elements the correct increasing order of first ionisation enthalpy is

- (a) $\text{Li} < \text{B} < \text{Be} < \text{C} < \text{O} < \text{N} < \text{F} < \text{Ne}$
 (b) $\text{Li} < \text{B} < \text{Be} < \text{C} < \text{N} < \text{O} < \text{F} < \text{Ne}$
 (c) $\text{Li} < \text{Be} < \text{B} < \text{C} < \text{O} < \text{N} < \text{F} < \text{Ne}$
 (d) $\text{Li} < \text{Be} < \text{B} < \text{C} < \text{N} < \text{O} < \text{F} < \text{Ne}$

64. Among the following, the narrow spectrum antibiotic is

- (a) ampicillin (b) amoxycillin
 (c) chloramphenicol (d) penicillin G

65. The method used to remove temporary hardness of water is

- (a) Clark's method
 (b) ion-exchange method
 (c) synthetic resins method
 (d) Calgon's method

66. Which of the following series of transitions in the spectrum of hydrogen atom fall in visible region?

- (a) Balmer series (b) Paschen series
 (c) Brackett series (d) Lyman series

67. Match the xenon compounds in Column I with its structure in Column II and assign the correct code:

	Column I		Column II
A.	XeF_4	(i)	Pyramidal
B.	XeF_6	(ii)	Square planar
C.	XeOF_4	(iii)	Distorted octahedral
D.	XeO_3	(iv)	Square pyramidal

Codes

- | | | | | |
|-----|-------|-------|-------|------|
| | A | B | C | D |
| (a) | (ii) | (iii) | (iv) | (i) |
| (b) | (ii) | (iii) | (i) | (iv) |
| (c) | (iii) | (iv) | (i) | (ii) |
| (d) | (i) | (ii) | (iii) | (iv) |

68. The structure of intermediate A in the following reaction, is

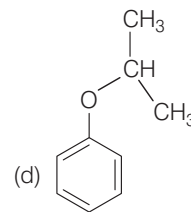
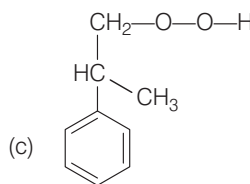
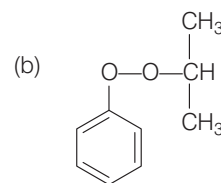
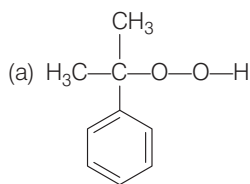
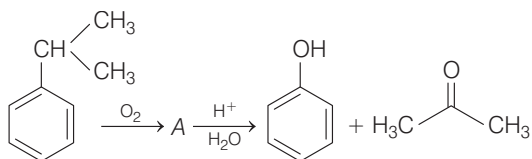

69. The correct structure of tribromooctaoxide is

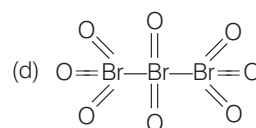
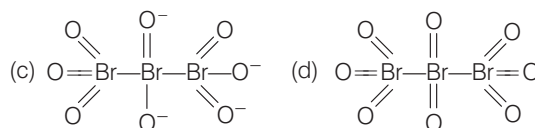
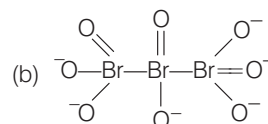
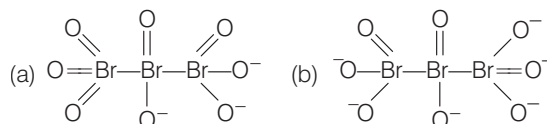

70. Which is the correct thermal stability order for H_2E (E = O, S, Se, Te and Po)?

- (a) $\text{H}_2\text{O} < \text{H}_2\text{S} < \text{H}_2\text{Se} < \text{H}_2\text{Te} < \text{H}_2\text{Po}$
 (b) $\text{H}_2\text{Po} < \text{H}_2\text{Te} < \text{H}_2\text{Se} < \text{H}_2\text{S} < \text{H}_2\text{O}$
 (c) $\text{H}_2\text{Se} < \text{H}_2\text{Te} < \text{H}_2\text{Po} < \text{H}_2\text{O} < \text{H}_2\text{S}$
 (d) $\text{H}_2\text{S} < \text{H}_2\text{O} < \text{H}_2\text{Se} < \text{H}_2\text{Te} < \text{H}_2\text{Po}$

71. In which case change in entropy is negative?

- (a) Expansion of a gas at constant temperature
 (b) Sublimation of solid to gas
 (c) $2\text{H}(g) \rightarrow \text{H}_2(g)$
 (d) Evaporation of water

72. A compound is formed by cation C and anion A. The anions form hexagonal close packed (hcp) lattice and the cations occupy 75% of octahedral voids.

The formula of the compound is

- (a) C_3A_2 (b) C_3A_4
 (c) C_4A_3 (d) C_2A_3

73. Among the following, the one that is not a green house gas is

- (a) methane (b) ozone
 (c) sulphur dioxide (d) nitrous oxide

8 NEET (National) Solved Paper 2019

74. Identify the incorrect statement related to PCl_5 from the following:

- (a) Two axial P—Cl bonds make an angle of 180° with each other
- (b) Axial P—Cl bonds are longer than equatorial P—Cl bonds
- (c) PCl_5 molecule is non-reactive
- (d) Three equatorial P—Cl bonds make an angle of 120° with each other

75. Which of the following is an amphoteric hydroxide?

- (a) $\text{Ca}(\text{OH})_2$
- (b) $\text{Mg}(\text{OH})_2$
- (c) $\text{Be}(\text{OH})_2$
- (d) $\text{Sr}(\text{OH})_2$

76. 4d, 5p, 5f and 6p-orbitals are arranged in the order of decreasing energy.

The correct option is

- (a) $6p > 5f > 5p > 4d$
- (b) $5p > 5f > 4d > 5p$
- (c) $5f > 6p > 4d > 5p$
- (d) $5f > 6p > 5p > 4d$

77. For the cell reaction,



$E_{\text{cell}}^{\circ} = 0.24 \text{ V}$ at 298 K. The standard Gibbs energy ($\Delta_r G^{\circ}$) of the cell reaction is

[Given that Faraday constant

$$F = 96500 \text{ C mol}^{-1}]$$

- (a) $-23.16 \text{ kJ mol}^{-1}$
- (b) $46.32 \text{ kJ mol}^{-1}$
- (c) $23.16 \text{ kJ mol}^{-1}$
- (d) $-46.32 \text{ kJ mol}^{-1}$

78. Conjugate base for Bronsted acids H_2O and HF are

- (a) H_3O^+ and F^{-} , respectively
- (b) OH^{-} and F^{-} , respectively
- (c) H_3O^+ and H_2F^{+} , respectively
- (d) OH^{-} and H_2F^{+} , respectively

79. Which one is malachite from the following?

- (a) $\text{Cu}(\text{OH})_2$
- (b) Fe_3O_4
- (c) $\text{CuCO}_3 \cdot \text{Cu}(\text{OH})_2$
- (d) CuFeS_2

80. pH of a saturated solution of $\text{Ca}(\text{OH})_2$ is 9.

The solubility product (K_{sp}) of $\text{Ca}(\text{OH})_2$ is

- (a) 0.25×10^{-10}
- (b) 0.125×10^{-15}
- (c) 0.5×10^{-10}
- (d) 0.5×10^{-15}

81. Which of the following is incorrect statement?

- (a) SiCl_4 is easily hydrolysed
- (b) GeX_4 ($X = \text{F}, \text{Cl}, \text{Br}, \text{I}$) is more stable than GeX_2
- (c) SnF_4 is ionic in nature
- (d) PbF_4 is covalent in nature

82. Which mixture of the solutions will lead to the formation of negatively charged colloidal $[\text{AgI}]\text{I}^{-}$ sol?

- (a) 50 mL of 1 M AgNO_3 + 50 mL of 2 M KI
- (b) 50 mL of 2 M AgNO_3 + 50 mL of 1.5 M KI
- (c) 50 mL of 1 M AgNO_3 + 50 mL of 0.1 M KI
- (d) 50 mL of 1 M AgNO_3 + 50 mL of 1.5 M KI

83. The mixture that forms maximum boiling azeotrope is

- (a) ethanol + water
- (b) acetone + carbon disulphide
- (c) heptane + octane
- (d) water + nitric acid

84. For a cell involving one electron, $E_{\text{cell}}^{\circ} = 0.59 \text{ V}$ at 298 K, the equilibrium constant for the cell reaction is

$$\left[\text{Given that, } \frac{2303 RT}{F} = 0.059 \text{ V at } T = 298 \text{ K} \right]$$

- (a) 1.0×10^5
- (b) 1.0×10^{10}
- (c) 1.0×10^{30}
- (d) 1.0×10^2

85. Among the following, the reaction that proceeds through an electrophilic substitution, is

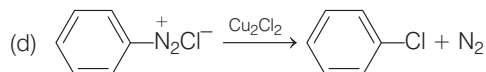
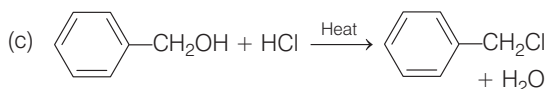
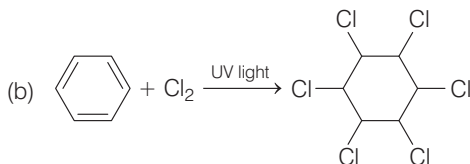
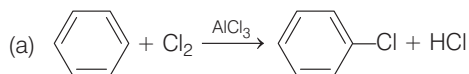

86. The major product of the following reaction is:

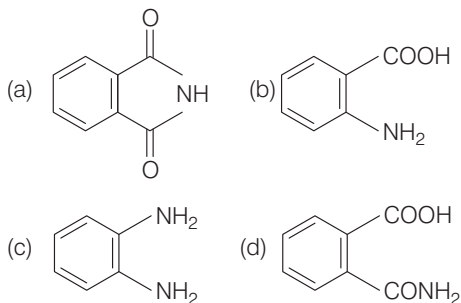
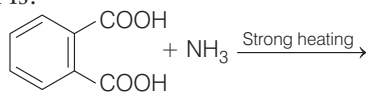

87. What is the correct electronic configuration of the central atom in $\text{K}_4[\text{Fe}(\text{CN})_6]$ based on crystal field theory?



88. If the rate constant for a first order reaction is k , the time (t) required for the completion of 99% of the reaction is given by

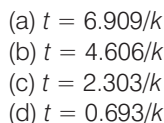

89. Under isothermal condition, a gas at 300 K expands from 0.1 L to 0.25 L against a constant external pressure of 2 bar.

The work done by the gas is
 (Given that 1 L bar = 100 J)



90. Enzymes that utilise ATP in phosphate transfer require an alkaline earth metal (M) as the cofactor. M is



BIOLOGY

91. Cells in G_0 phase

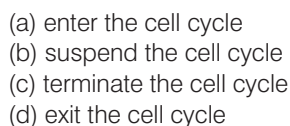

92. Phloem in gymnosperms lacks

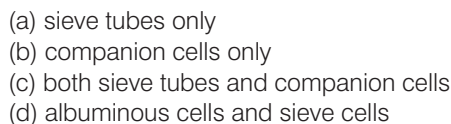

93. Which of the following factors is responsible for the formation of concentrated urine?

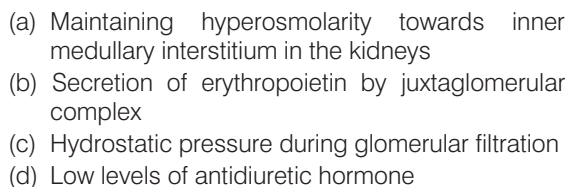

94. Match the hominids with their correct brain size

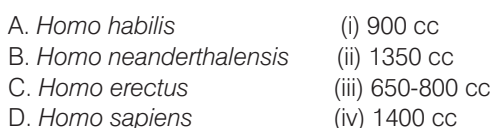

Select the correct option.

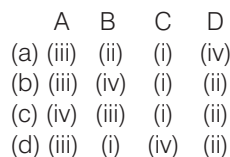

95. Match the following genes of the *Lac* operon with their respective products



Select the correct option.

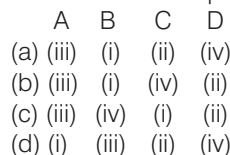

96. In some plants, the female gamete develops into embryo without fertilisation.

This phenomenon is known as

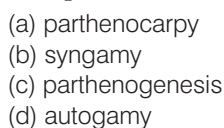

10 NEET (National) Solved Paper 2019

- 97.** Under which of the following conditions will there be no change in the reading frame of following mRNA?
5' AACAGCGGUGCUAUU3'
- (a) Deletion of G from 5th position
(b) Insertion of A and G at 4th and 5th positions, respectively
(c) Deletion of GGU from 7th, 8th and 9th positions
(d) Insertion of G at 5th position
- 98.** Which of the following muscular disorders is inherited?
- (a) Muscular dystrophy (b) Myasthenia gravis
(c) Botulism (d) Tetany
- 99.** Select the correct option.
- (a) 11th and 12th pairs of ribs are connected to the sternum with the help of hyaline cartilage
(b) Each rib is a flat thin bone and all the ribs are connected dorsally to the thoracic vertebrae and ventrally to the sternum
(c) There are seven pairs of vertebrosteral, three pairs of vertebrochondral and two pairs of vertebral ribs
(d) 8th, 9th and 10th pairs of ribs articulate directly with the sternum
- 100.** Grass leaves curl inwards during very dry weather.
Select the most appropriate reason from the following
- (a) Flaccidity of bulliform cells
(b) Shrinkage of air spaces in spongy mesophyll
(c) Tyloses in vessels
(d) Closure of stomata
- 101.** In *Antirrhinum* (Snapdragon), a red flower was crossed with a white flower and in F_1 -generation, pink flowers were obtained. When pink flowers were selfed, the F_2 -generation showed white, red and pink flowers.
Choose the incorrect statement from the following
- (a) Pink colour in F_1 is due to incomplete dominance
(b) Ratio of F_2 is $\frac{1}{4}$ (Red) : $\frac{2}{4}$ (Pink) : $\frac{1}{4}$ (White)
(c) Law of segregation does not apply in this experiment
(d) This experiment does not follow the principle of dominance
- 102.** Xylem translocates
- (a) water and mineral salts only
(b) water, mineral salts and some organic nitrogen only
(c) water, mineral salts, some organic nitrogen and hormones
(d) water only
- 103.** Placentation in which ovules develop on the inner wall of the ovary or in peripheral part, is
- (a) axile (b) parietal
(c) free central (d) basal
- 104.** Which of the following glucose transporters is insulin-dependent?
- (a) GLUT II (b) GLUT III
(c) GLUT IV (d) GLUT I
- 105.** Select the incorrect statement.
- (a) Inbreeding is essential to evolve purelines in any animal
(b) Inbreeding selects harmful recessive genes that reduce fertility and productivity
(c) Inbreeding helps in accumulation of superior genes and elimination of undesirable genes
(d) Inbreeding increases homozygosity
- 106.** Select the incorrect statement.
- (a) In male grasshoppers, 50% of sperms have no sex-chromosome
(b) In domesticated fowls, sex of progeny depends on the type of sperm rather than egg
(c) Human males have one of their sex chromosomes much shorter than the other
(d) Male fruitfly is heterogametic
- 107.** Colostrum, the yellowish fluid, secreted by mother during the initial days of lactation is very essential to impart immunity to the new born infants because it contains
- (a) monocytes (b) macrophages
(c) immunoglobulin A (d) natural killer cells
- 108.** A gene locus has two alleles A, a. If the frequency of dominant allele A is 0.4, then what will be the frequency of homozygous dominant, heterozygous and homozygous recessive individuals in the population?
- (a) 0.16(AA); 0.24(Aa); 0.36(aa)
(b) 0.16(AA); 0.48(Aa); 0.36(aa)
(c) 0.16(AA); 0.36(Aa); 0.48(aa)
(d) 0.36(AA); 0.48(Aa); 0.16(aa)

109. Which of the following statements regarding mitochondria is incorrect?

- (a) Enzymes of electron transport are embedded in outer membrane
- (b) Inner membrane is convoluted with infoldings
- (c) Mitochondrial matrix contains single circular DNA molecule and ribosomes
- (d) Outer membrane is permeable to monomers of carbohydrates, fats and proteins

110. What triggers activation of protoxin to active *Bt* toxin of *Bacillus thuringiensis* in bollworm?

- (a) Moist surface of midgut
- (b) Alkaline pH of gut
- (c) Acidic pH of stomach
- (d) Body temperature

111. It takes very long time for pineapple plants to produce flowers. Which combination of hormones can be applied to artificially induce flowering in pineapple plants throughout the year to increase yield?

- (a) Gibberellin and Cytokinin
- (b) Gibberellin and Absciscic acid
- (c) Cytokinin and Absciscic acid
- (d) Auxin and Ethylene

112. In a species, the weight of newborn ranges from 2 to 5 kg. 97% of the newborn with an average weight between 3 to 3.3 kg survive whereas 99% of the infants born with weights from 2 to 2.5 kg or 4.5 to 5 kg die. Which type of selection process is taking place?

- (a) Stabilising selection
- (b) Disruptive selection
- (c) Cyclical selection
- (d) Directional selection

113. Which of the following can be used as a biocontrol agent in the treatment of plant disease?

- (a) *Chlorella*
- (b) *Anabaena*
- (c) *Lactobacillus*
- (d) *Trichoderma*

114. Concanavalin A is

- (a) an essential oil
- (b) a lectin
- (c) a pigment
- (d) an alkaloid

115. Match the following hormones with the respective disease.

A. Insulin	(i)	Addison's disease
B. Thyroxin	(ii)	Diabetes insipidus
C. Corticoids	(iii)	Acromegaly
D. Growth hormone	(iv)	Goitre
	(v)	Diabetes mellitus

Select the correct option.

- | | A | B | C | D |
|-----|------|------|-------|-------|
| (a) | (ii) | (iv) | (iii) | (i) |
| (b) | (v) | (iv) | (i) | (iii) |
| (c) | (ii) | (iv) | (i) | (iii) |
| (d) | (v) | (i) | (ii) | (iii) |

116. What is the fate of the male gametes discharged in the synergid?

- (a) All fuse with the egg
- (b) One fuses with the egg, other(s) fuse(s) with synergid nucleus
- (c) One fuses with the egg and other fuses with central cell nuclei
- (d) One fuses with the egg other(s) degenerate (s) in the synergid

117. Match the following structures with their respective location in organs.

Column I	Column II
A. Crypts of Lieberkuhn	(i) Pancreas
B. Glisson's capsule	(ii) Duodenum
C. Islets of Langerhans	(iii) Small intestine
D. Brunner's glands	(iv) Liver

Select the correct option from the following

- | | A | B | C | D |
|-----|-------|------|------|-------|
| (a) | (ii) | (iv) | (i) | (iii) |
| (b) | (iii) | (iv) | (i) | (ii) |
| (c) | (iii) | (ii) | (i) | (iv) |
| (d) | (iii) | (i) | (ii) | (iv) |

118. Which one of the following is not a method of *in situ* conservation of biodiversity?

- (a) Wildlife sanctuary
- (b) Botanical garden
- (c) Sacred grove
- (d) Biosphere reserve

12 NEET (National) Solved Paper 2019

- 119.** Expressed Sequence Tags (ESTs) refers to
 (a) polypeptide expression
 (b) DNA polymorphism
 (c) novel DNA sequences
 (d) genes expressed as RNA
- 120.** Which of the following ecological pyramids is generally inverted?
 (a) Pyramid of energy
 (b) Pyramid of biomass in a forest
 (c) Pyramid of biomass in a sea
 (d) Pyramid of numbers in grassland
- 121.** Which of the following pairs of gases is mainly responsible for greenhouse effect?
 (a) Oxygen and Nitrogen
 (b) Nitrogen and Sulphur dioxide
 (c) Carbon dioxide and Methane
 (d) Ozone and Ammonia
- 122.** Which of the following immune responses is responsible for rejection of kidney graft?
 (a) Humoral immune response
 (b) Inflammatory immune response
 (c) Cell-mediated immune response
 (d) Auto-immune response
- 123.** *Pinus* seed cannot germinate and establish without fungal association. This is because
 (a) it has obligate association with mycorrhizae
 (b) it has very hard seed coat
 (c) its seeds contain inhibitors that prevent germination
 (d) its embryo is immature
- 124.** Which of the statements given below is not true about formation of annual rings in trees?
 (a) Differential activity of cambium causes light and dark bands of tissue early and late wood, respectively
 (b) Activity of cambium depends upon variation in climate
 (c) Annual rings are not prominent in trees of temperate region
 (d) Annual ring is a combination of springwood and autumnwood produced in a year
- 125.** Purines found both in DNA and RNA are
 (a) adenine and guanine
 (b) guanine and cytosine
 (c) cytosine and thymine
 (d) adenine and thymine
- 126.** Variations caused by mutation, as proposed by Hugo de Vries are
 (a) random and directionless
 (b) small and directional
 (c) small and directionless
 (d) random and directional
- 127.** Which of the following statements is not correct?
 (a) The hydrolytic enzymes of lysosomes are active under acidic pH
 (b) Lysosomes are membrane bound structures
 (c) Lysosomes are formed by the process of packaging in the endoplasmic reticulum
 (d) Lysosomes have numerous hydrolytic enzymes
- 128.** The shorter and longer arms of a submetacentric chromosome are referred to as
 (a) p-arm and q-arm, respectively
 (b) q-arm and p-arm, respectively
 (c) m-arm and n-arm, respectively
 (d) s-arm and l-arm, respectively
- 129.** The ciliated epithelial cells are required to move particles or mucus in a specific direction. In humans, these cells are mainly present in
 (a) Fallopian tubes and pancreatic duct
 (b) eustachian tube and salivary duct
 (c) bronchioles and Fallopian tubes
 (d) bile duct and bronchioles
- 130.** Which of the following statements is incorrect?
 (a) *Claviceps* is a source of many alkaloids and LSD
 (b) Conidia are produced exogenously and ascospores endogenously
 (c) Yeasts have filamentous bodies with long thread-like hyphae
 (d) Morels and truffles are edible delicacies
- 131.** Match Column I with Column II.
- | Column I | Column II |
|---------------|---|
| A. Saprophyte | (i) Symbiotic association of fungi with plant roots |
| B. Parasite | (ii) Decomposition of dead organic materials |
| C. Lichens | (iii) Living on living plants or animals |
| D. Mycorrhiza | (iv) Symbiotic association of algae and fungi |

Choose the correct answer from the option given below:

- | | | | | |
|-----|-------|-------|-------|------|
| | A | B | C | D |
| (a) | (iii) | (ii) | (i) | (iv) |
| (b) | (ii) | (i) | (iii) | (iv) |
| (c) | (ii) | (iii) | (iv) | (i) |
| (d) | (i) | (ii) | (iii) | (iv) |

132. Which of the following is a commercial blood cholesterol lowering agent?

- | | |
|-------------|-------------------|
| (a) Statin | (b) Streptokinase |
| (c) Lipases | (d) Cyclosporin A |

133. *Thiobacillus* is a group of bacteria helpful in carrying out

- (a) chemoautotrophic-fixation
 (b) nitrification
 (c) denitrification
 (d) nitrogen-fixation

134. Polyblend, a fine powder of recycled modified plastic, has proved to be a good material for

- (a) use as a fertiliser
 (b) construction of roads
 (c) making tubes and pipes
 (d) making plastic sacks

135. Select the correct sequence of organs in the alimentary canal of cockroach starting from mouth

- (a) Pharynx → Oesophagus → Gizzard → Crop → Ileum → Colon → Rectum
 (b) Pharynx → Oesophagus → Gizzard → Ileum → Crop → Colon → Rectum
 (c) Pharynx → Oesophagus → Ileum → Crop → Gizzard → Colon → Rectum
 (d) Pharynx → Oesophagus → Crop → Gizzard → Ileum → Colon → Rectum

136. Identify the correct pair representing the causative agent of typhoid fever and the confirmatory test for typhoid.

- (a) *Streptococcus pneumoniae* / Widal test
 (b) *Salmonella typhi* / Anthrone test
 (c) *Salmonella typhi* / Widal test
 (d) *Plasmodium vivax* / UTI test

137. What would be the heart rate of a person if the cardiac output is 5 L, blood volume in the ventricles at the end of diastole is 100 mL and at the end of ventricular systole is 50 mL?

- (a) 75 beats per minute (b) 100 beats per minute
 (c) 125 beats per minute (d) 50 beats per minute

138. Which of the following statements is incorrect?

- (a) Viruses are obligate parasites
 (b) Infective constituent in viruses is the protein coat
 (c) Prions consist of abnormally folded proteins
 (d) Viroids lack a protein coat

139. Consider the following statement

- (A) Coenzyme or metal ion that is tightly bound to enzyme protein is called prosthetic group.
 (B) A complete catalytic active enzyme with its bound prosthetic group is called apoenzyme.

Select the correct option.

- (a) (A) is true but (B) is false
 (b) Both (A) and (B) are false
 (c) (A) is false but (B) is true
 (d) Both (A) and (B) are true

140. What map unit (Centimorgan) is adopted in the construction of genetic maps?

- (a) A unit of distance between two expressed genes representing 100% cross over
 (b) A unit of distance between genes on chromosomes, representing 1% cross over
 (c) A unit of distance between genes on chromosomes, representing 50% cross over
 (d) A unit of distance between two expressed genes representing 10% cross over

141. Extrusion of second polar body from egg nucleus occurs

- (a) after fertilisation
 (b) before the entry of sperm into ovum
 (c) simultaneously with first cleavage
 (d) after the entry of sperm but before fertilisation

142. What is the site of perception of photoperiod necessary for induction of flowering in plants?

- | | |
|--------------|------------------|
| (a) Pulvinus | (b) Shoot apex |
| (c) Leaves | (d) Lateral buds |

143. Match the following organisms with their respective characteristics.

	Column I		Column II
A.	<i>Pila</i>	(i)	Flame cells
B.	<i>Bombyx</i>	(ii)	Comb plates
C.	<i>Pleurobrachia</i>	(iii)	Radula
D.	<i>Taenia</i>	(iv)	Malpighian tubules

14 NEET (National) Solved Paper 2019

Select the correct option from the following :

- | | | | | |
|-----|-------|------|-------|------|
| | A | B | C | D |
| (a) | (iii) | (iv) | (ii) | (i) |
| (b) | (ii) | (iv) | (iii) | (i) |
| (c) | (iii) | (ii) | (iv) | (i) |
| (d) | (iii) | (ii) | (i) | (iv) |

144. The correct sequence of phases of cell cycle is

- (a) $G_1 \rightarrow G_2 \rightarrow S \rightarrow M$
- (b) $S \rightarrow G_1 \rightarrow G_2 \rightarrow M$
- (c) $G_1 \rightarrow S \rightarrow G_2 \rightarrow M$
- (d) $M \rightarrow G_1 \rightarrow G_2 \rightarrow S$

145. Which of the following protocols did aim for reducing emission of chlorofluorocarbons into the atmosphere?

- (a) Kyoto Protocol
- (b) Gothenburg Protocol
- (c) Geneva Protocol
- (d) Montreal Protocol

146. Match the following organisms with the products they produce

A. <i>Lactobacillus</i>	(i)	Cheese
B. <i>Saccharomyces cerevisiae</i>	(ii)	Curd
C. <i>Aspergillus niger</i>	(iii)	Citric acid
D. <i>Acetobacter aceti</i>	(iv)	Bread
	(v)	Acetic acid

Select the correct option.

- | | | | | |
|-----|-------|------|-------|-------|
| | A | B | C | D |
| (a) | (ii) | (iv) | (iii) | (v) |
| (b) | (iii) | (iv) | (v) | (i) |
| (c) | (ii) | (i) | (iii) | (v) |
| (d) | (ii) | (iv) | (v) | (iii) |

147. Which of the following contraceptive methods do involve a role of hormone?

- (a) Barrier method, Lactational amenorrhea, Pills
- (b) Cu-T, Pills, Emergency contraceptives
- (c) Pills, Emergency contraceptives, Barrier methods
- (d) Lactational amenorrhea, Pills, Emergency contraceptives

148. Which of the following sexually transmitted diseases is not completely curable?

- (a) Genital warts
- (b) Genital herpes
- (c) Chlamydia
- (d) Gonorrhoea

149. The frequency of recombination between gene pairs on the same chromosome as a measure of the distance between genes was explained by

- (a) Gregor J Mendel
- (b) Alfred Sturtevant
- (c) Sutton-Boveri
- (d) TH Morgan

150. From evolutionary point of view, retention of the female gametophyte with developing young embryo on the parent sporophyte for some time, is first observed in

- (a) mosses
- (b) pteridophytes
- (c) gymnosperms
- (d) liverworts

151. What is the direction of movement of sugars in phloem?

- (a) Upward
- (b) Downward
- (c) Bidirectional
- (d) Non-multidirectional

152. The Earth Summit held in Rio de Janeiro in 1992 was called

- (a) for conservation of biodiversity and sustainable utilisation of its benefits
- (b) to assess threat posed to native species by invasive weed species
- (c) for immediate steps to discontinue the use of CFCs that were damaging the ozone layer
- (d) to reduce CO_2 emissions and global warming

153. Use of an artificial kidney during hemodialysis may result in :

- A. Nitrogenous waste build-up in the body
- B. Non-elimination of excess potassium ions
- C. Reduced absorption of calcium ions from gastrointestinal tract
- D. Reduced RBC production

Which of the following options is the most appropriate?

- (a) (B) and (C) are correct
- (b) (C) and (D) are correct
- (c) (A) and (D) are correct
- (d) (A) and (B) are correct

154. Conversion of glucose to glucose-6-phosphate, the first irreversible reaction of glycolysis, is catalysed by

- (a) hexokinase
- (b) enolase
- (c) phosphofructokinase
- (d) aldolase

155. Which one of the following statements regarding post-fertilisation development in flowering plants is incorrect?

- (a) Zygote develops into embryo
- (b) Central cell develops into endosperm
- (c) Ovules develop into embryo sac
- (d) Ovary develops into fruit

156. Consider the following features.

- A. Organ system level of organisation
- B. Bilateral symmetry
- C. True coelomates with segmentation of body

Select the correct option of animal groups which possess all the above characteristics.

- (a) Annelida, Arthropoda and Mollusca
- (b) Arthropoda, Mollusca and Chordata
- (c) Annelida, Mollusca and Chordata
- (d) Annelida, Arthropoda and Chordata

157. Select the correct group of biocontrol agents.

- (a) *Trichoderma*, *Baculovirus*, *Bacillus thuringiensis*
- (b) *Oscillatoria*, *Rhizobium*, *Trichoderma*
- (c) *Nostoc*, *Azospirillum*, *Nucleopolyhedrovirus*
- (d) *Bacillus thuringiensis*, Tobacco mosaic virus, Aphids

158. Identify the cells whose secretion protects the lining of gastrointestinal tract from various enzymes.

- (a) Goblet cells
- (b) Oxyntic cells
- (c) Duodenal cells
- (d) Chief cells

159. Which one of the following equipments is essentially required for growing microbes on a large scale, for industrial production of enzymes?

- (a) Sludge digester
- (b) Industrial oven
- (c) Bioreactor
- (d) BOD incubator

160. Which of the following is true for Golden rice?

- (a) It is pest resistant, with a gene from *Bacillus thuringiensis*
- (b) It is drought tolerant, developed using *Agrobacterium* vector
- (c) It has yellow grains, because of a gene introduced from a primitive variety of rice
- (d) It is vitamin-A enriched, with a gene from daffodil

161. Which of the following statements is correct?

- (a) Cornea consists of dense connective tissue of elastin and can repair itself
- (b) Cornea is convex, transparent layer which is highly vascularised
- (c) Cornea consists of dense matrix of collagen and is the most sensitive portion of the eye
- (d) Cornea is an external, transparent and protective proteinaceous covering of the eyeball

162. Respiratory Quotient (RQ) value of tripalmitin is

- (a) 0.7
- (b) 0.07
- (c) 0.09
- (d) 0.9

163. Which of these following methods is the most suitable for disposal of nuclear waste?

- (a) Bury the waste under Antarctic ice-cover
- (b) Dump the waste within rocks under deep ocean
- (c) Bury the waste within rocks deep below the Earth's surface
- (d) Shoot the waste into space

164. Match the following columns.

Column I	Column II
A. P - wave	(i) Depolarisation of ventricles
B. QRS complex	(ii) Repolarisation of ventricles
C. T-wave	(iii) Coronary ischemia
D. Reduction in the Size of T-wave	(iv) Depolarisation of atria
	(v) Repolarisation of atria

Select the correct option.

- | | | | | |
|-----|------|-------|------|-------|
| | A | B | C | D |
| (a) | (iv) | (i) | (ii) | (v) |
| (b) | (ii) | (i) | (v) | (iii) |
| (c) | (ii) | (iii) | (v) | (iv) |
| (d) | (iv) | (i) | (ii) | (iii) |

165. Tidal Volume and Expiratory Reserve Volume of an athlete is 500 mL and 1000 mL, respectively. What will be his Expiratory Capacity if the Residual Volume is 1200 mL?

- (a) 1700 mL
- (b) 2200 mL
- (c) 2700 mL
- (d) 1500 mL

16 NEET (National) Solved Paper 2019

- 166.** Which of the following is the most important cause for animals and plants being driven to extinction?
- Drought and floods
 - Economic exploitation
 - Alien species invasion
 - Habitat loss and fragmentation
- 167.** Select the correctly written scientific name of Mango which was first described by Carolus Linnaeus.
- Mangifera indica* Linn.
 - Mangifera indica*
 - Mangifera Indica*
 - Mangifera indica* Car. Linn.
- 168.** Following statements describe the characteristics of the enzyme Restriction Endonuclease. Identify the incorrect statement.
- The enzyme binds DNA at specific sites and cuts only one of the two strands
 - The enzyme cuts the sugar-phosphate backbone at specific sites on each strand
 - The enzyme recognises a specific palindromic nucleotide sequence in the DNA
 - The enzyme cuts DNA molecule at identified position within the DNA
- 169.** What is the genetic disorder in which an individual has an overall masculine development gynaecomastia and is sterile ?
- Klinefelter's syndrome
 - Edward syndrome
 - Down's syndrome
 - Turner's syndrome
- 170.** Which of the following pairs of organelles does not contain DNA?
- Chloroplast and Vacuoles
 - Lysosomes and Vacuoles
 - Nuclear envelope and Mitochondria
 - Mitochondria and Lysosomes
- 171.** How does steroid hormone influence the cellular activities?
- Binding to DNA and forming a gene-hormone complex
 - Activating cyclic AMP located on the cell membrane
 - Using aquaporin channels as second messenger
 - Changing the permeability of the cell membrane
- 172.** Select the correct sequence for transport of sperm cells in male reproductive system.
- Seminiferous tubules → Rete testis → Vasa efferentia → Epididymis → Vas deferens → Ejaculatory duct → Urethra → Urethral meatus
 - Seminiferous tubules → Vasa efferentia → Epididymis → Inguinal canal → Urethra
 - Testis → Epididymis → Vasa efferentia → Vas deferens → Ejaculatory duct → Inguinal canal → Urethra → Urethral meatus
 - Testis → Epididymis → Vasa efferentia → Rete testis → Inguinal canal → Urethra
- 173.** The concept of '*Omnis cellula-e-cellula*' regarding cell division was first proposed by
- Theodor Schwann
 - Schleiden
 - Aristotle
 - Rudolf Virchow
- 174.** Drug called 'Heroin' is synthesised by
- acetylation of morphine
 - glycosylation of morphine
 - nitration of morphine
 - methylation of morphine
- 175.** Persistent nucellus in the seed is known as
- perisperm
 - hilum
 - tegmen
 - chalaza
- 176.** Due to increasing air-borne allergens and pollutants, many people in urban areas are suffering from respiratory disorder causing wheezing due to
- inflammation of bronchi and bronchioles
 - proliferation of fibrous tissues and damage of the alveolar walls
 - reduction in the secretion of surfactants by pneumocytes
 - benign growth on mucous lining of nasal cavity

NEET (National) Solved Paper 2019 17

177. DNA precipitation out of a mixture of biomolecules can be achieved by treatment with

- (a) chilled ethanol
- (b) methanol at room temperature
- (c) chilled chloroform
- (d) isopropanol

178. Select the hormone- releasing Intra-Uterine Devices.

- (a) Multiload 375, Progestasert
- (b) Progestasert, LNG-20
- (c) Lippes Loop, Multiload 375
- (d) Vaults, LNG-20

179. Which of the following features of genetic code does allow bacteria to produce human insulin by recombinant DNA technology?

- (a) Genetic code is redundant
- (b) Genetic code is nearly universal
- (c) Genetic code is specific
- (d) Genetic code is not ambiguous

180. Which part of the brain is responsible for thermoregulation?

- (a) Hypothalamus
- (b) Corpus callosum
- (c) Medulla oblongata
- (d) Cerebrum

Answers

1.	(a)	2.	(c)	3.	(a)	4.	(a)	5.	(d)	6.	(b)	7.	(a)	8.	(b)	9.	(b)	10.	(c)
----	-----	----	-----	----	-----	----	-----	----	-----	----	-----	----	-----	----	-----	----	-----	-----	-----